

Jednodimenzionální křemík

F. Schauer

Fakulta chemická VUT

skupina fyziky

**O. Salyk, M. Weiter, I. Kuřitka , N. Dokoupil,
M. Otevřel a P. Horváth**

Polysilyleny (česky) – polysilylenes (anglicky)

Téze

- 1. Proč křemík s různou dimenzionalitou ?**
- 2. Chemie křemíku s různou dimenzionalitou**
- 3. Vlastnosti vedoucí k aplikacím**
- 4. Proč plazma ?**
- 5. Degradace, metastabilita – rezisty?**

1. Proč ?

WHY

1D SILICONS?

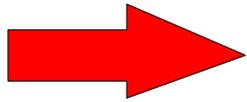

Silic ons -
mobility and luminescence

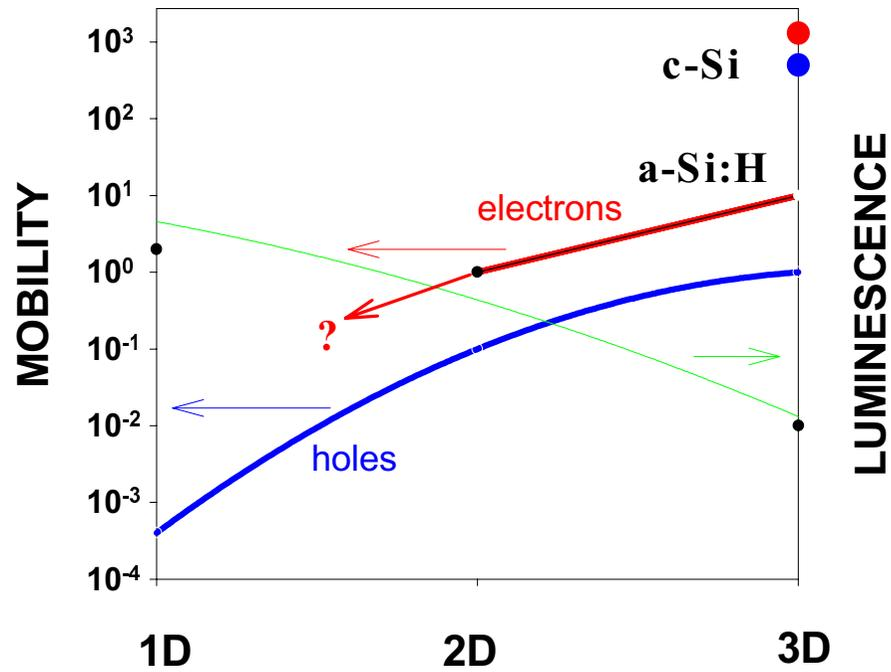

VÝVOJ VELIKOSTI SOUČÁSTEK

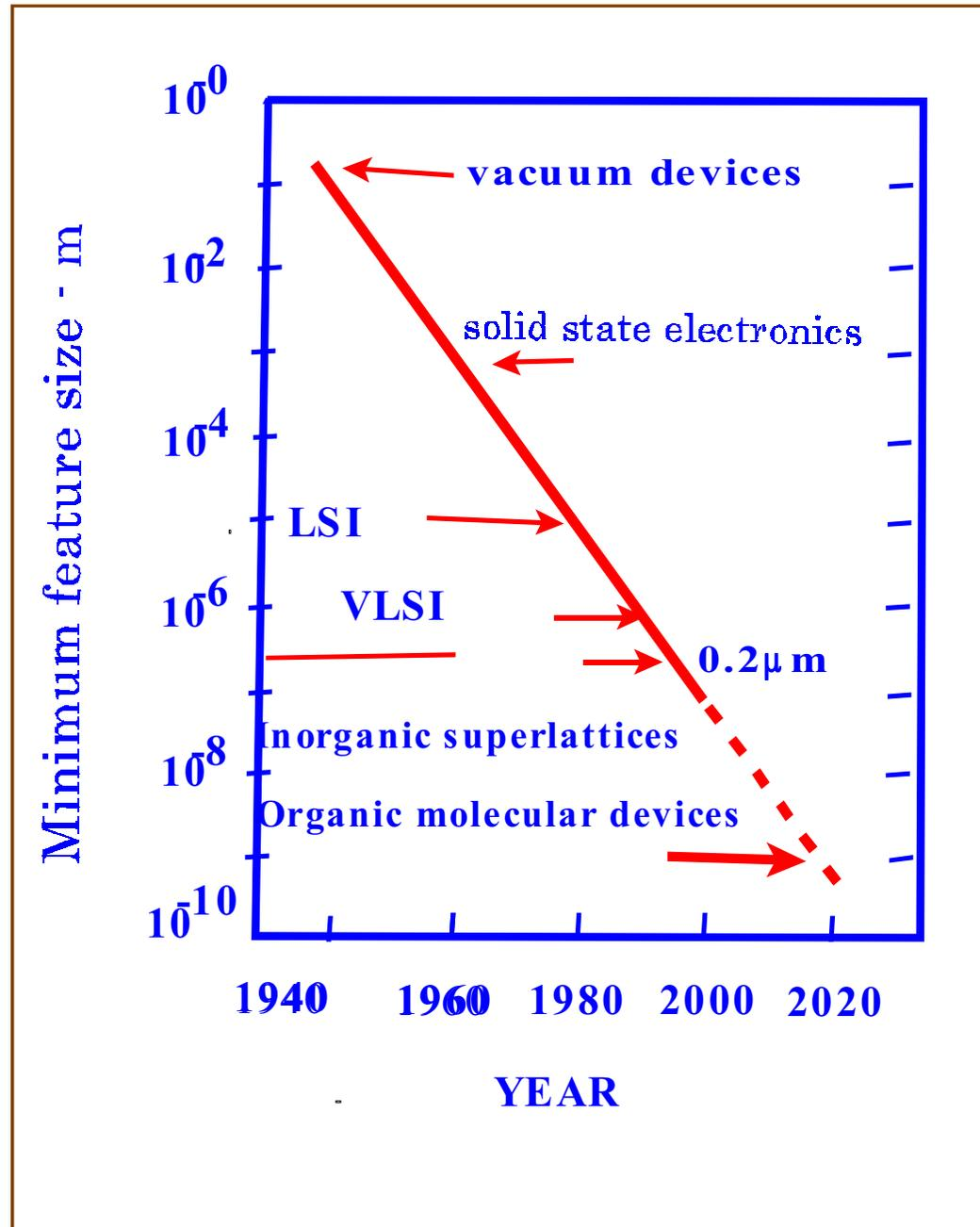

NANOSTRUKTURY

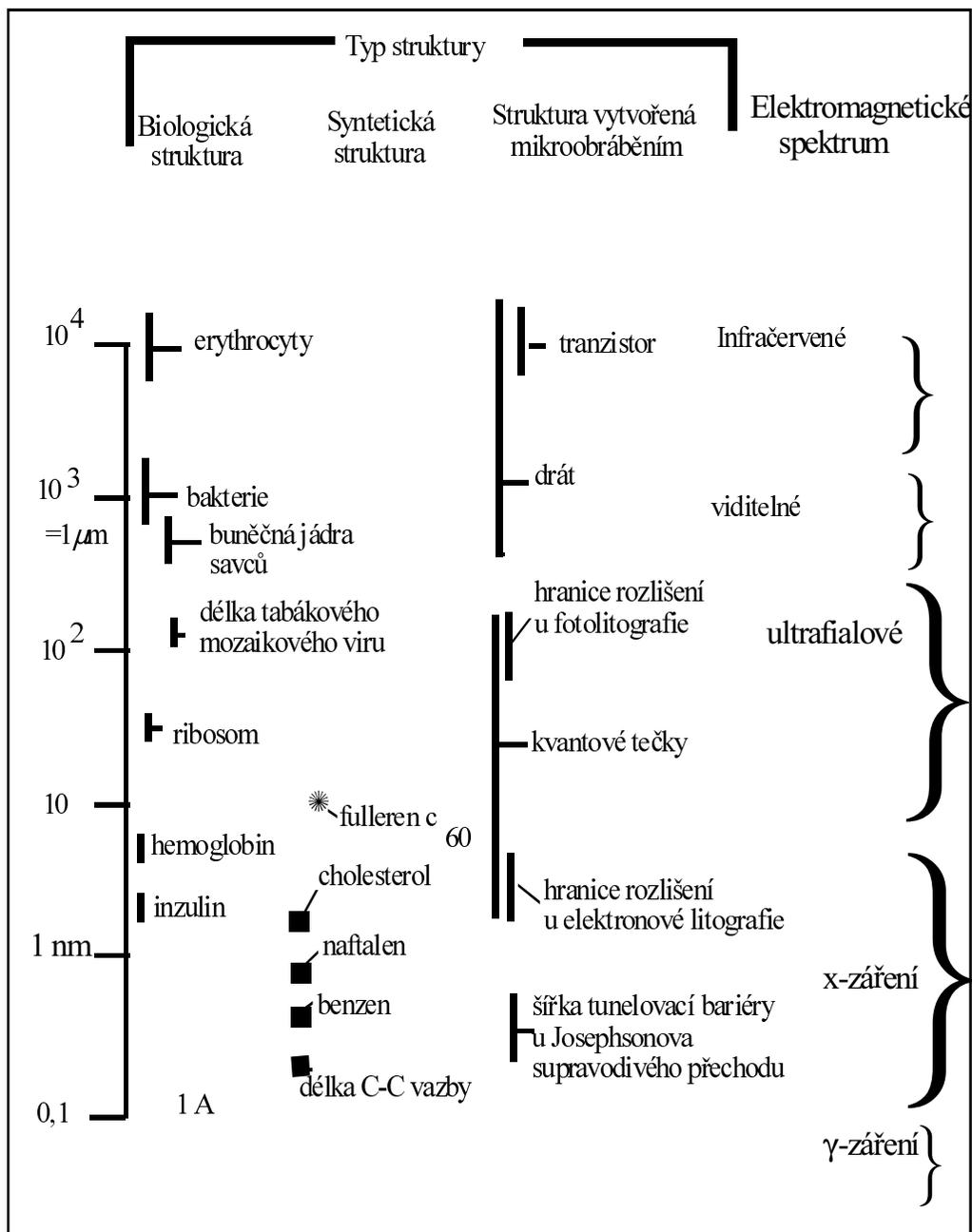

POLYMERIC PHOTOCONDUCTORS

π -CONJUGATED BACKBONE
E.G. POLY(ACETYLENE)

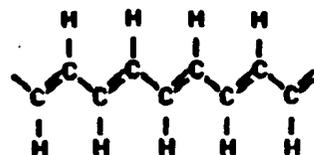

σ -CONJUGATED BACKBONE
E.G. POLYSILANES

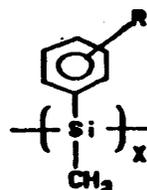

SATURATED BACKBONE
WITH SIDE CHAINS CONTAINING
 π -CONJUGATED CHROMOPHORES
E.G. POLY(N-VINYLCARBAZOLE)

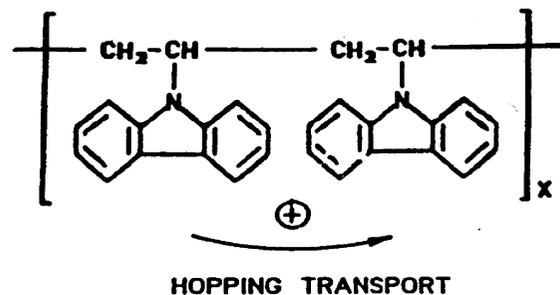

CONJUGATED BACKBONE
WITH SIDE CHAINS CONTAINING
 π -CONJUGATED CHROMOPHORES
E.G. POLY(N-(2-PROPINYLCARBAZOLE)

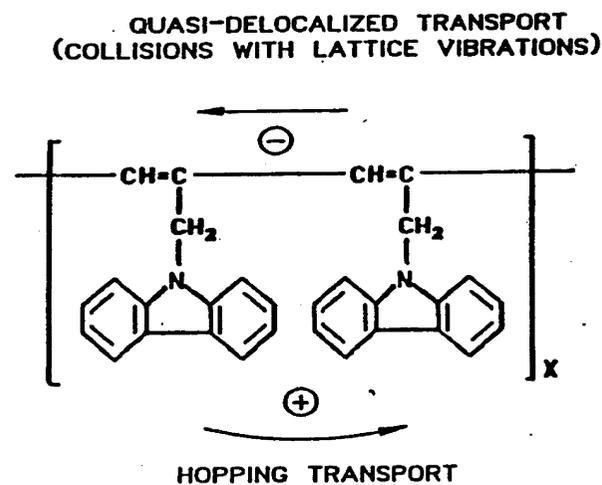

QUASI-DELOCALIZED TRANSPORT
(COLLISIONS WITH LATTICE VIBRATIONS)

2. Chemie 1D-3D křemíku

Silicons with different dimensionality

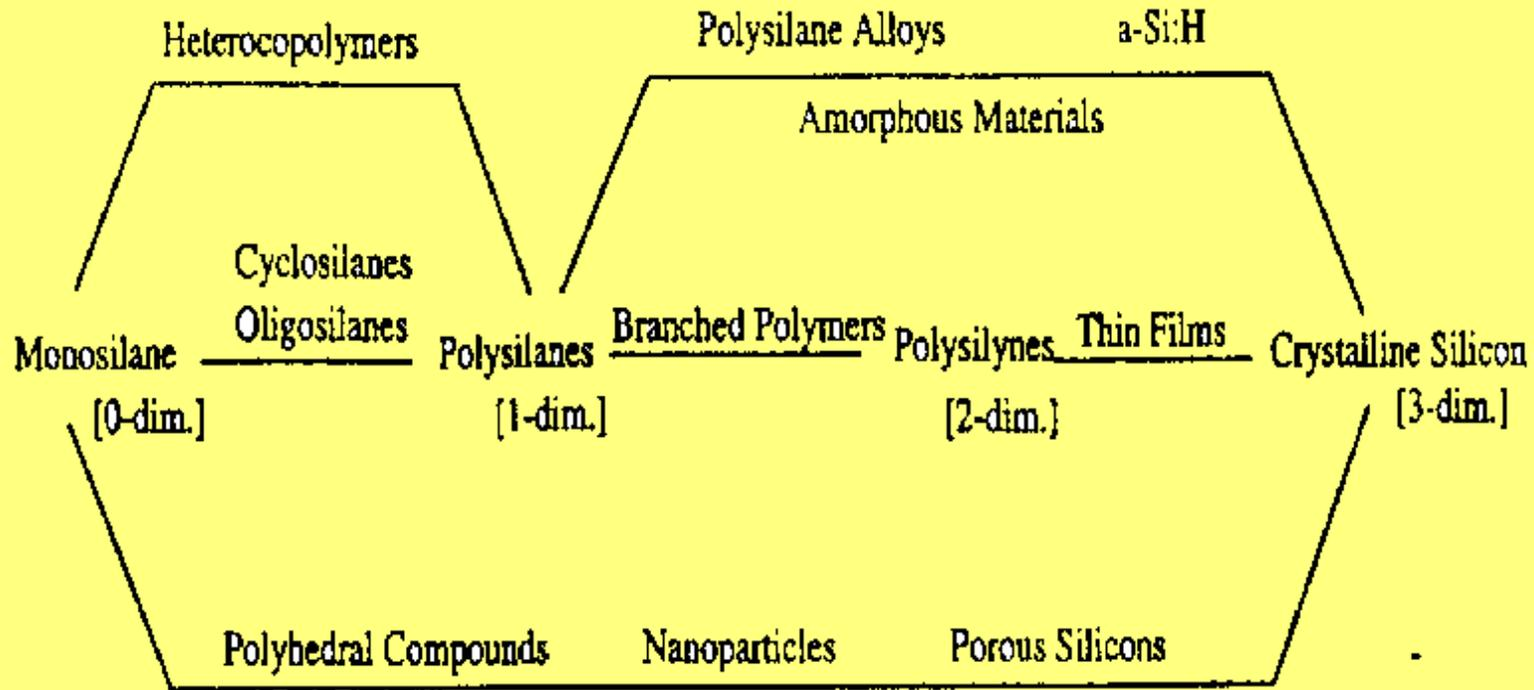
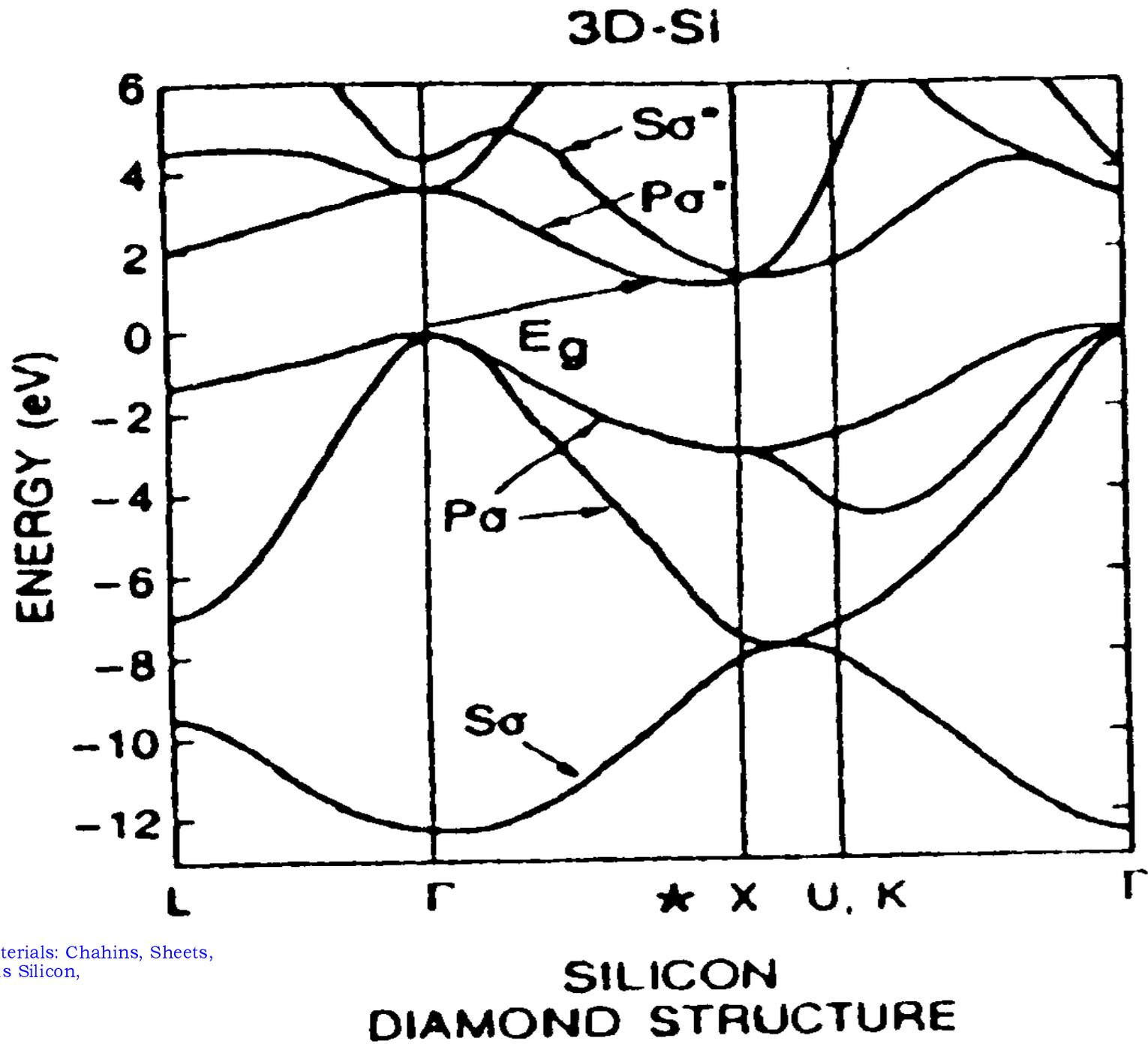

Fig. 3. An overview of silicon-based materials.

↑ **1D** ↑ **2D** ↑ **3D**

3D electron structure



L.Brus : Luminescence of Silicon Materials: Chahins, Sheets,
Nanowires, Microcrystals, and Porous Silicon,
J.Phys.Chem. 98,(1994)3575

2D electron structure

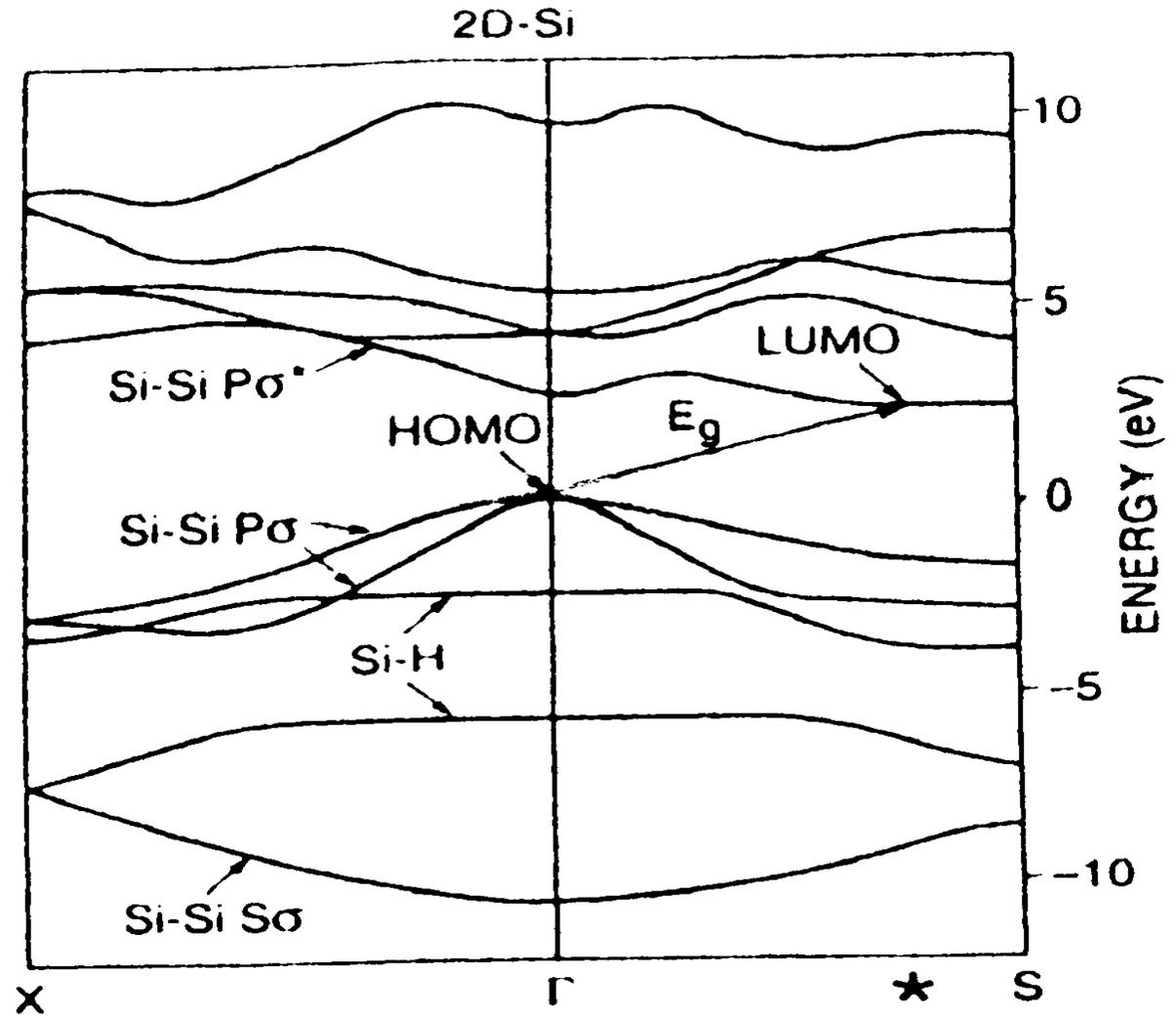

Puckered sheet polysilyne $(SiH)_n$

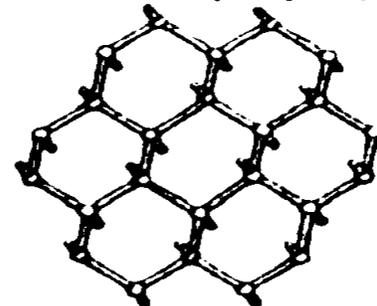

1D electron structure

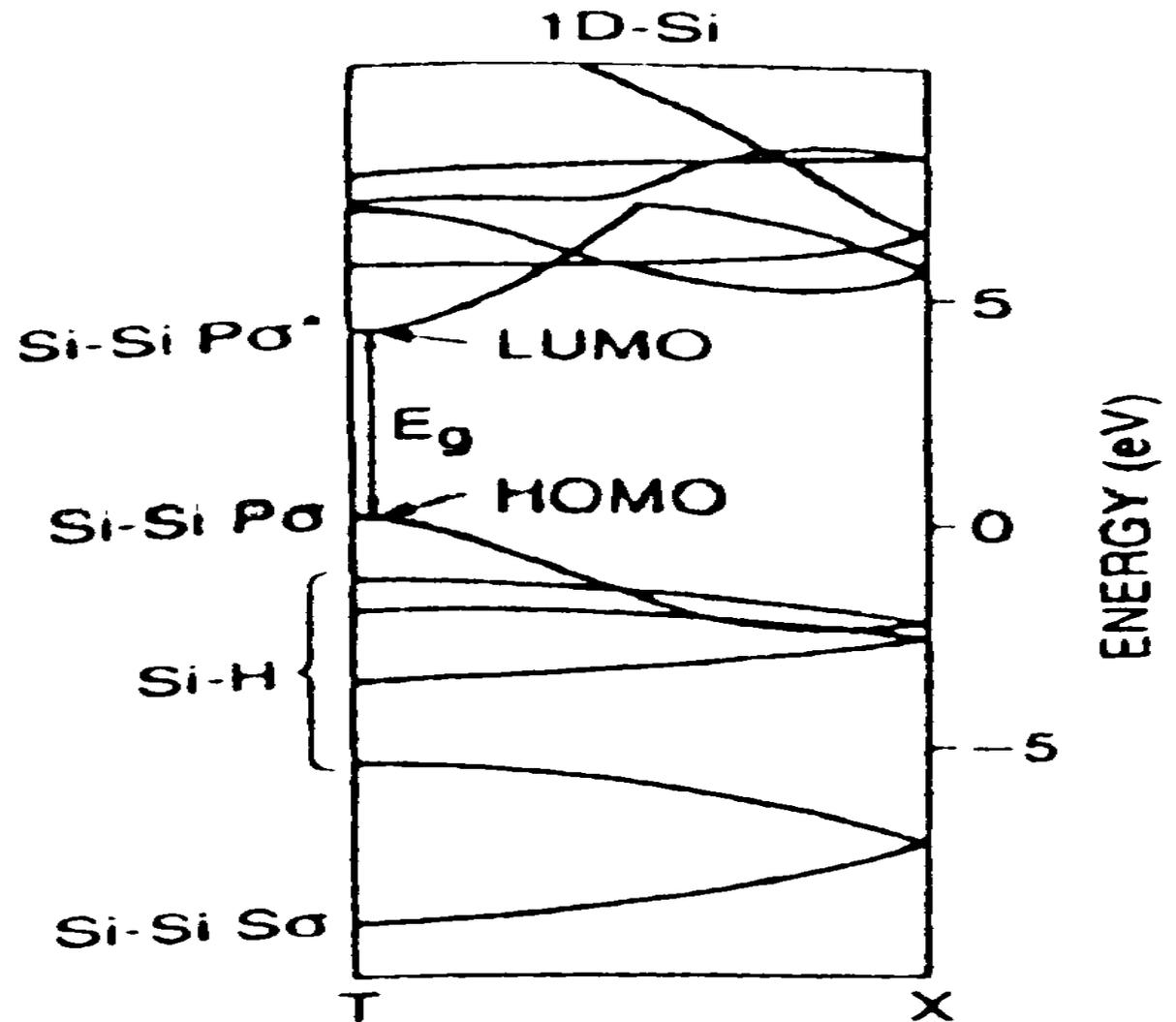

Trans-polysilane $(SiH_2)_n$
chain

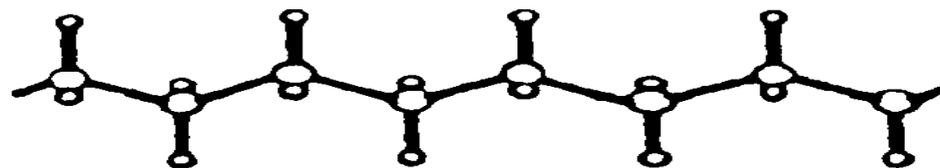

VIP

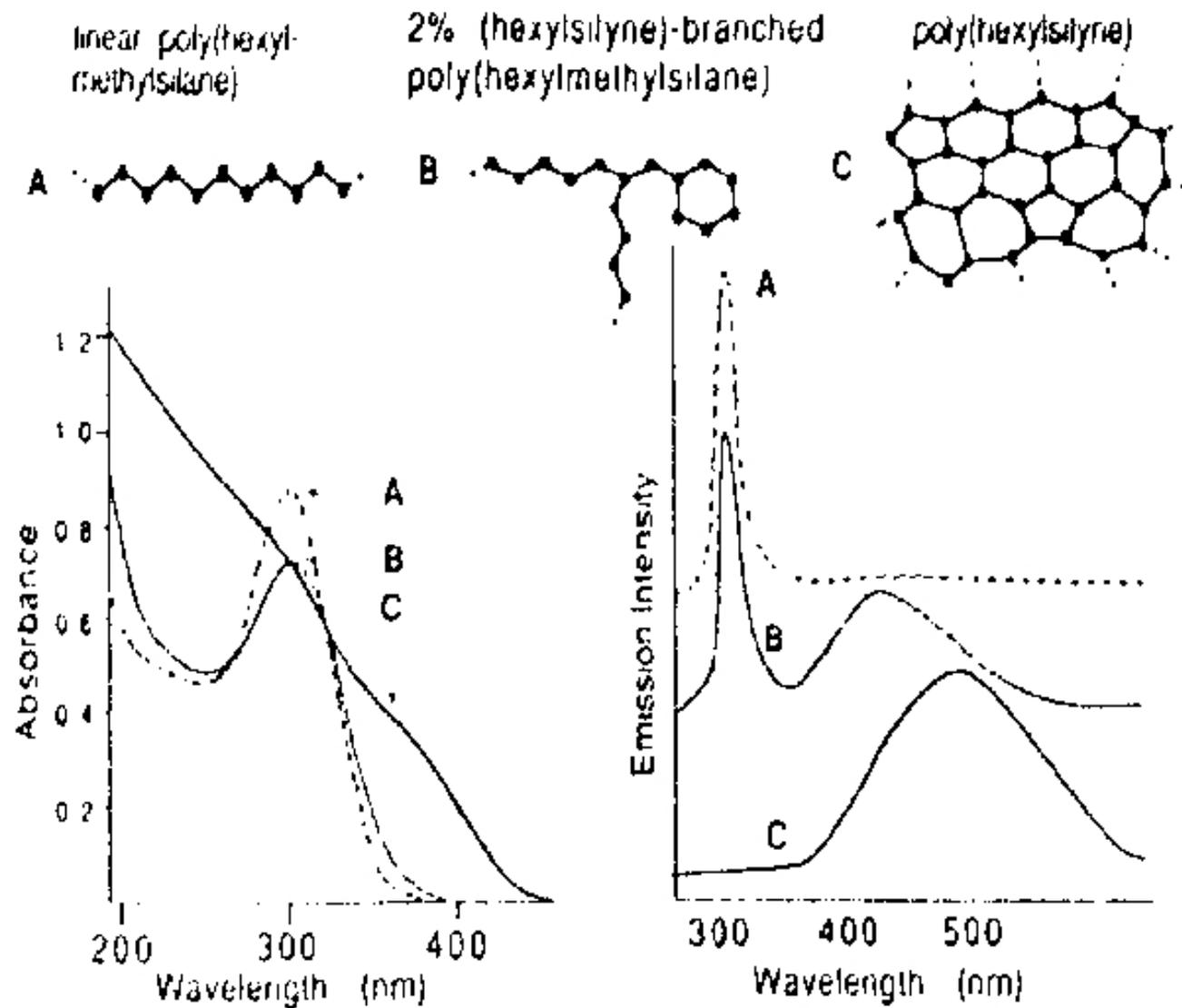

Figure 4. Optical absorption and emission spectra of 1D-Si and 2D-Si samples from ref 16a.

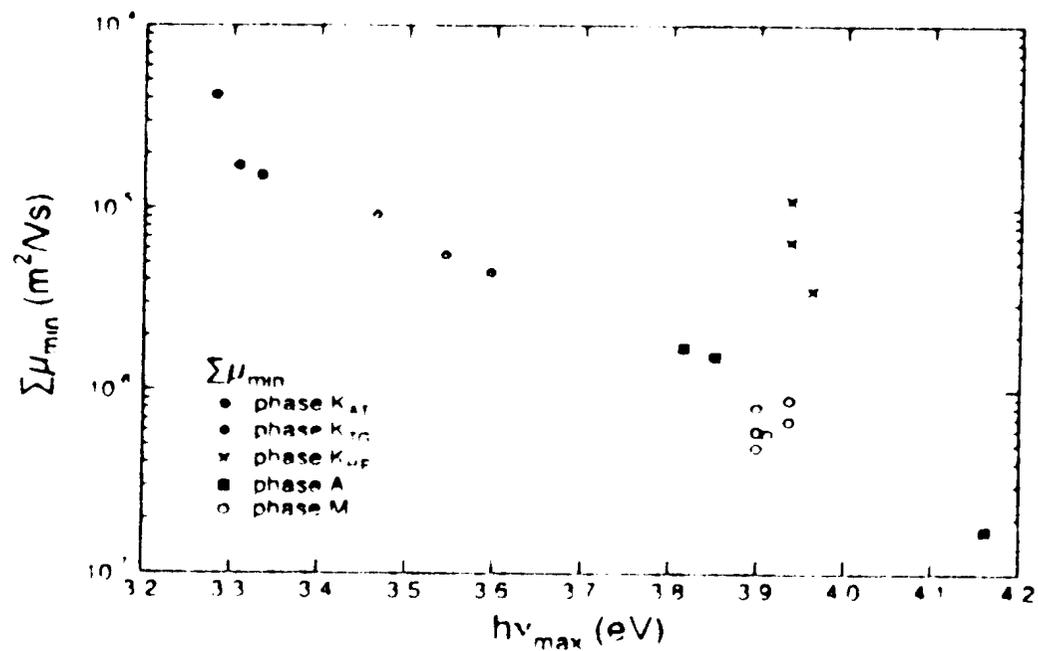
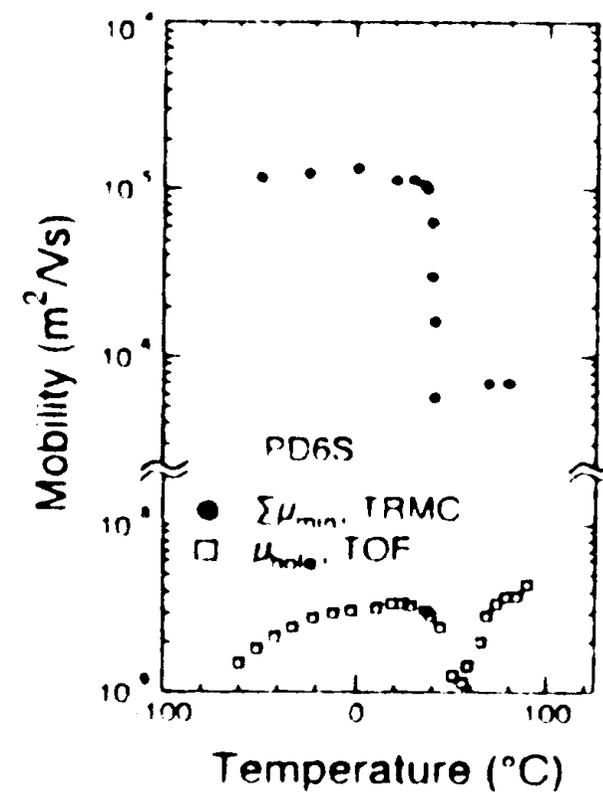

Figure 12. Charge carrier mobilities, $\Sigma\mu_{\min}$, vs the UV-absorption maximum.

Garrett P. vander Laan, et al, Charge Carrier Mobilities in Substituted Polysilylenes: Influence of Backbone Conformation,

J.Phys. Chem. 100 (1996),5470



3. Vlastnosti a aplikace

Carbon

Ground state

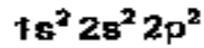

Benzene

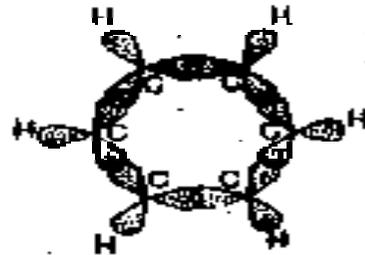

Silicon

Ground state

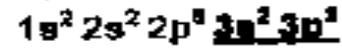

sp^3 hybrid orbitals
located on the silicon atom

all-trans

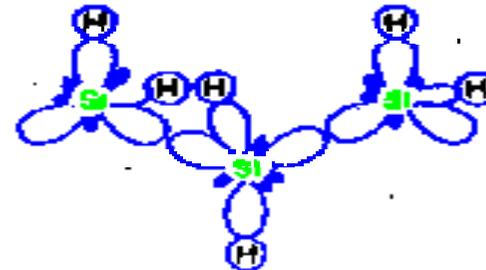

Linear chain

Polyene
 π -conjugated chain of
interacting C 2p orbitals

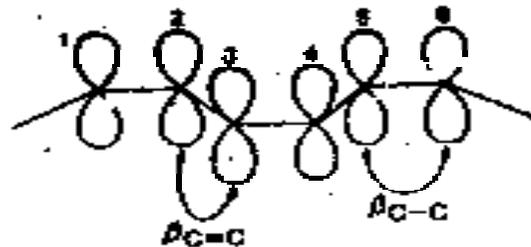

Poly(silylene)
 σ -conjugated chain of
interacting Si $3sp^3$ orbitals

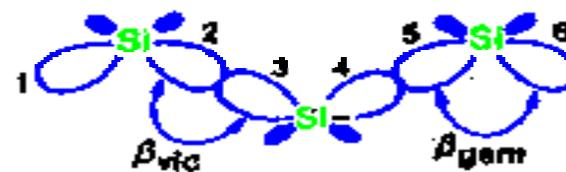

Similar Germanium
 $1s^2 2s^2 2p^6 3s^2 3p^6 3d^{10} 4s^2 4p^2$

**TUNED
LUMINESCENCE**



1D SILICONS prospect: UV (polarized) electroluminescence

poly(dibuthylsilylene) poly(diphenylsilylene) polydihexylsilylene

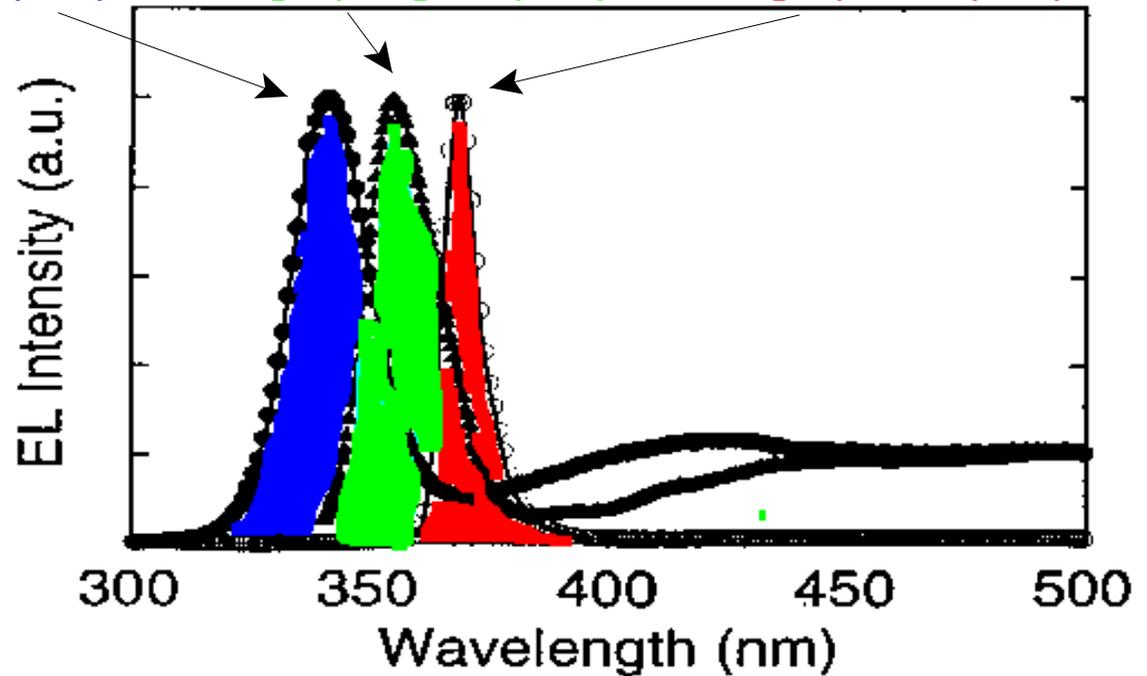

Fig. 7. The EL spectrum of PDBS (●), PDPS (▲) and PDHS (○). The spectrum was measured at 100 K for PDBS and PDHS and at 200 K for PDPS.

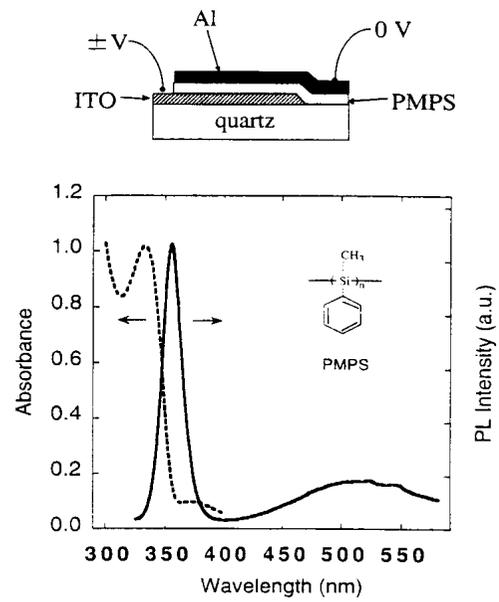
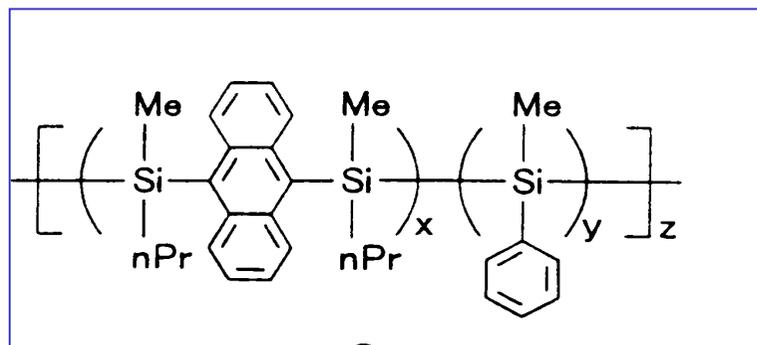

Fig. 1 A schematic diagram of the LED structure, together with absorption (broken line) and PL (solid line, excitation wavelength 300 nm) spectra of PMPS (thickness 120 nm).



ORDERING



1D silicon-mobility poly(di-npentylsilylane)

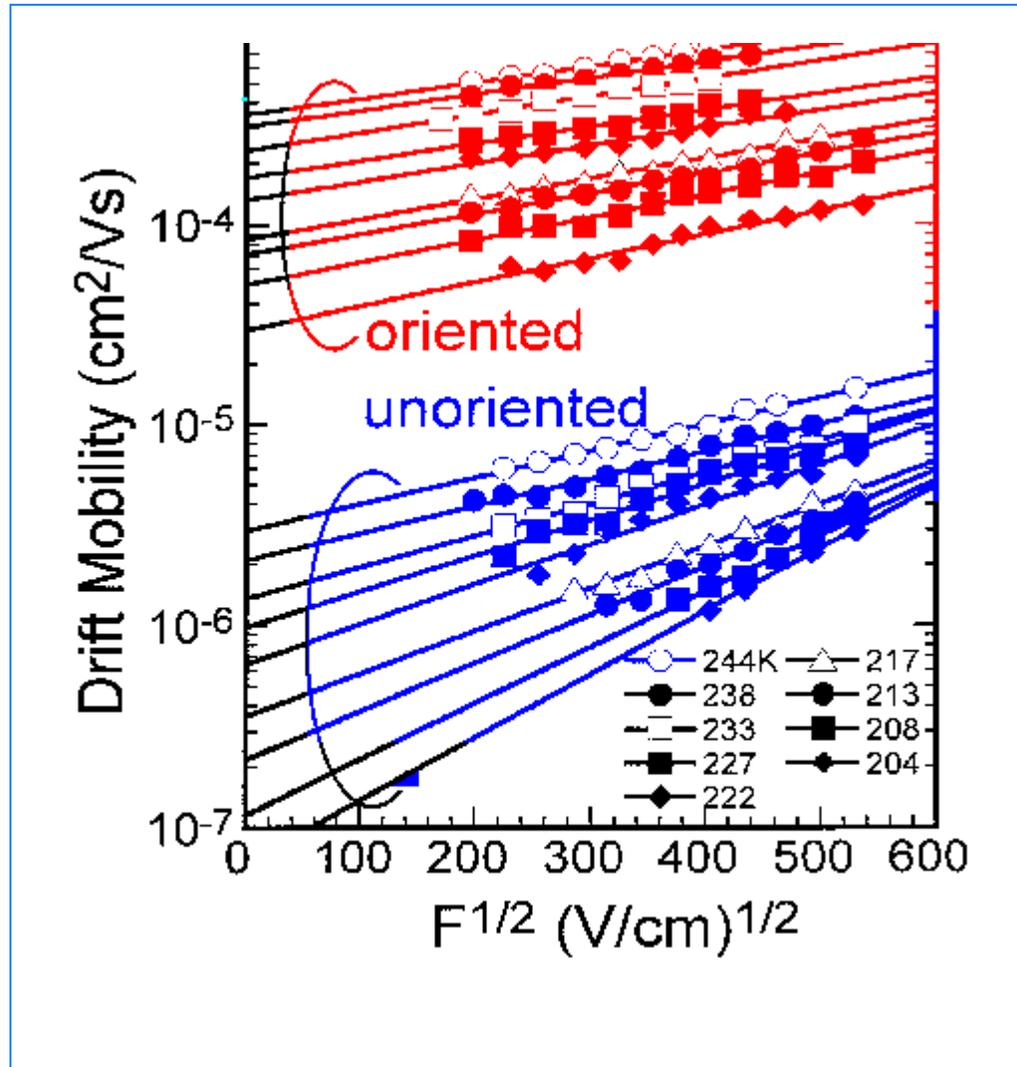

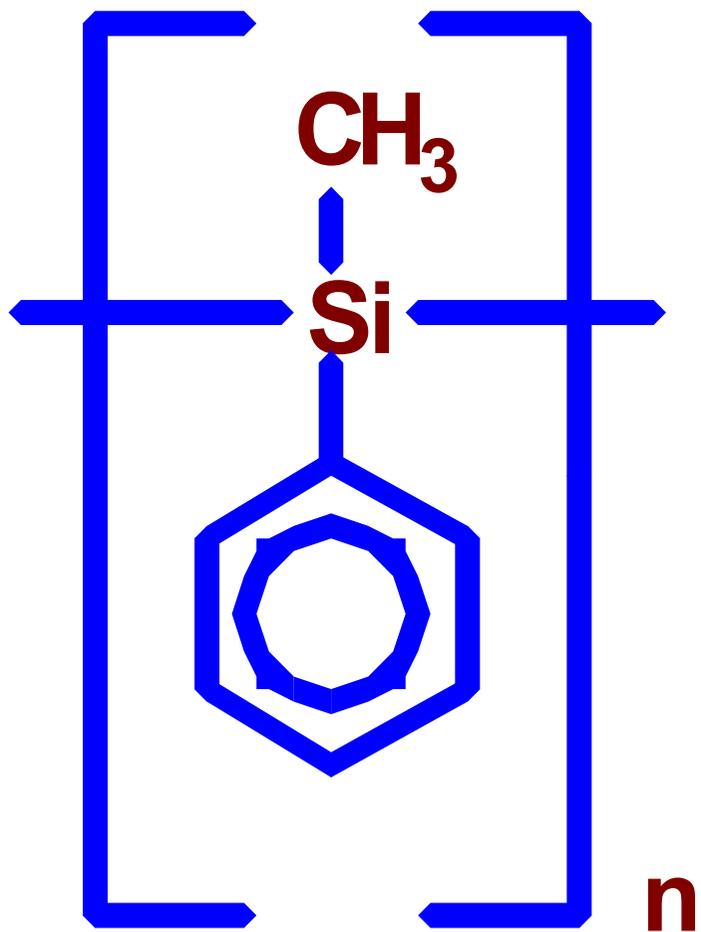

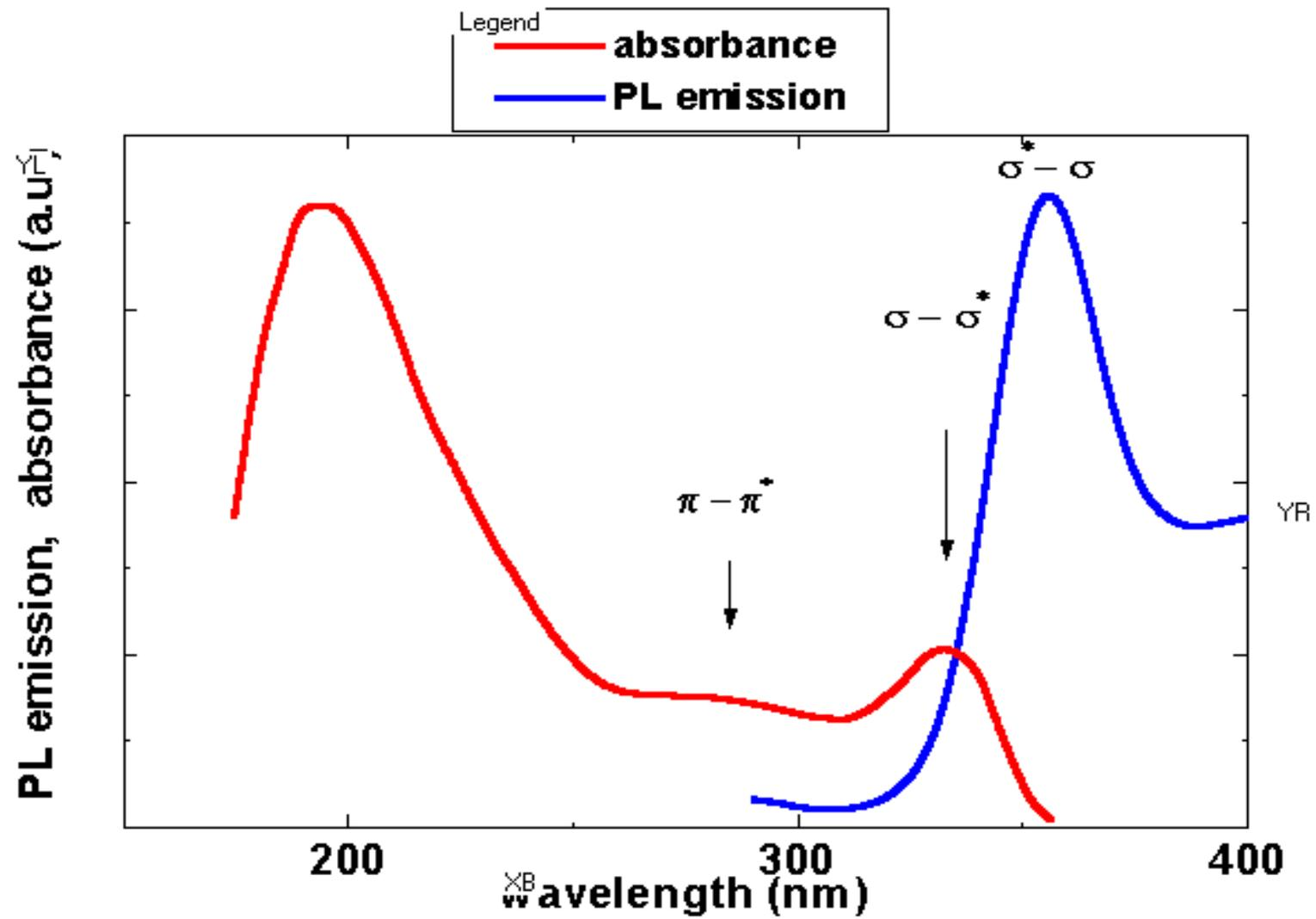

S. Nespurek, F. Schauer, and A. Kadashchuk : Visible Photoluminescence in Polysilanes, Chemical Monthly 132(2001),159-168,

Fotoelektronové spektroskopie

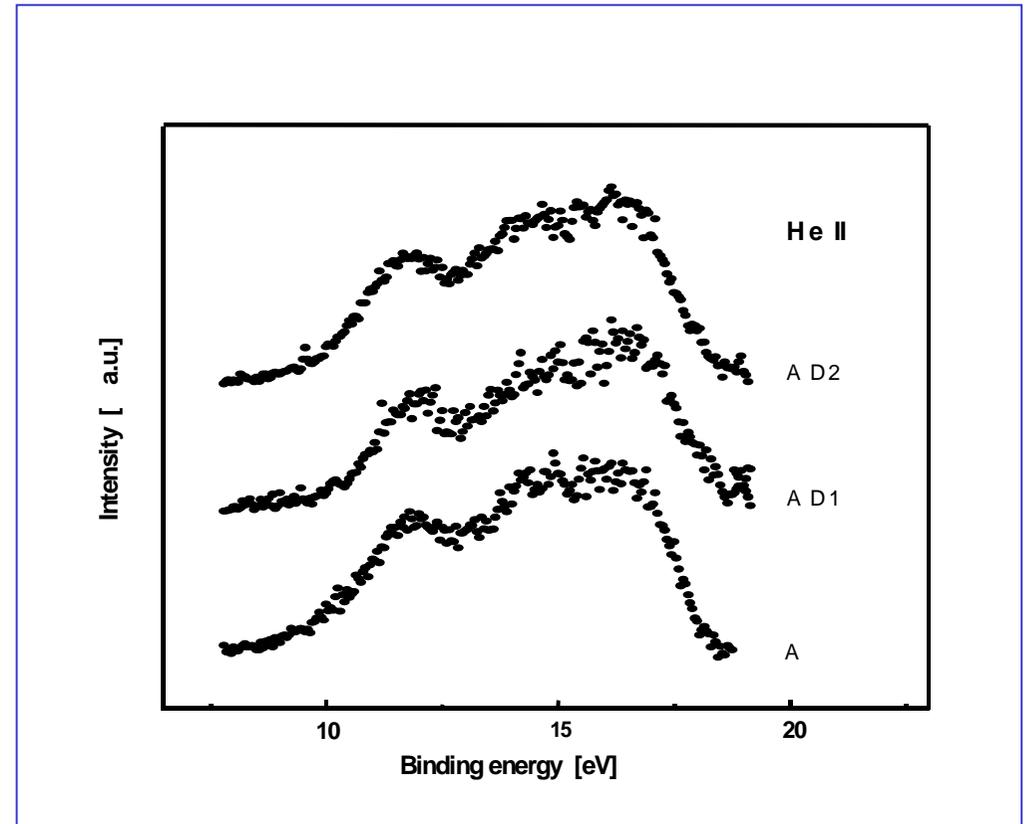
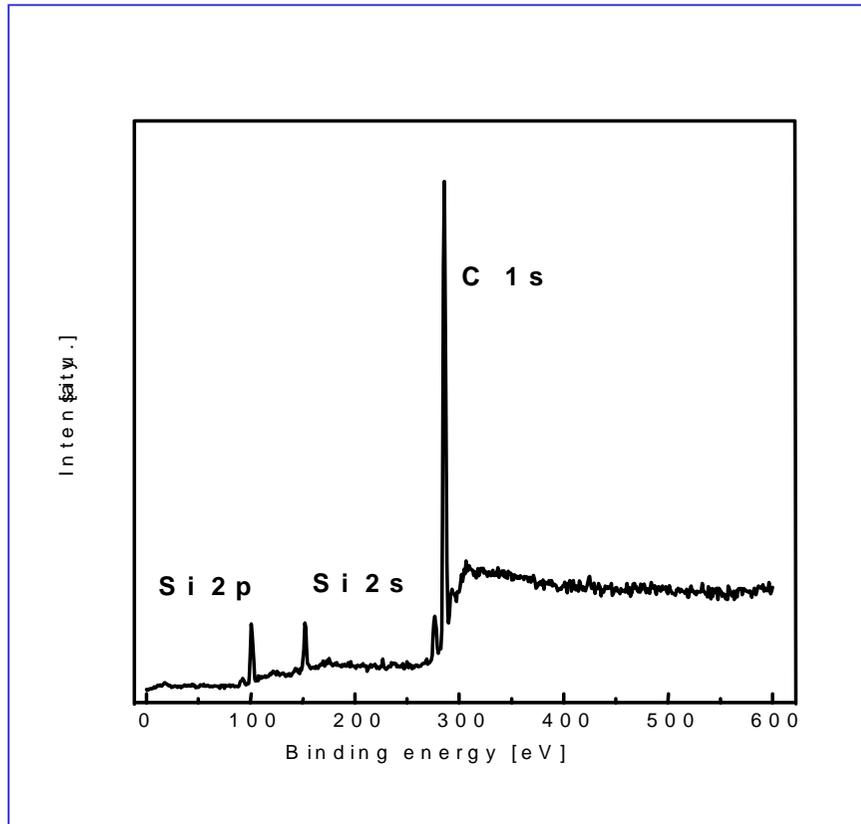

Fig. 2: A survey XPS spectrum from the pristine PMPSi; mind the absence of oxygen related lines [4]

Fig.3: UV induced valence band spectra of the pristine PMPSi surface (A) and after (D1) and (D2) degradation steps using Xe I resonant irradiation [4]

4. Proč plasma?

UV laser ablation

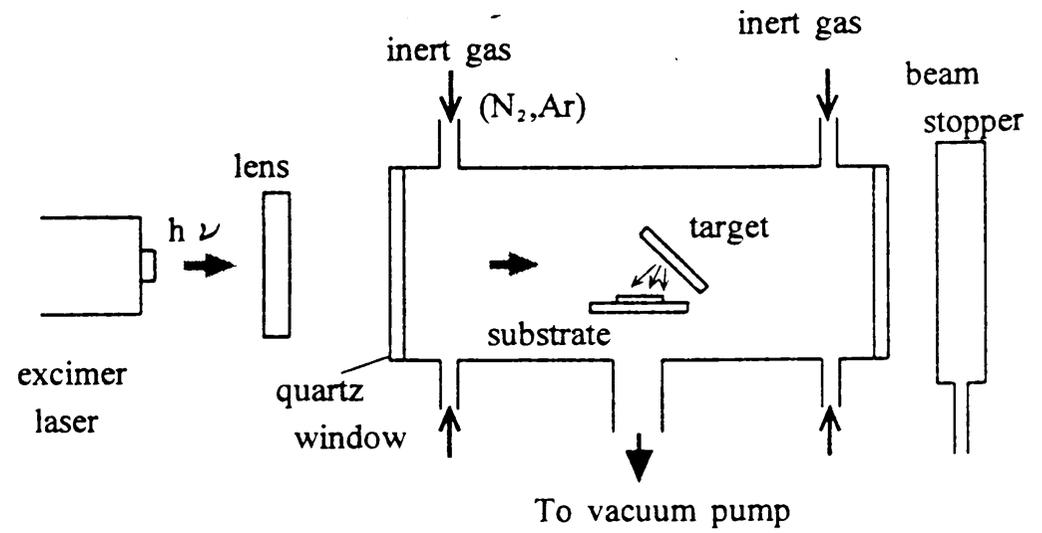

Fig. 1. Schematic diagram of the laser ablation reactor.

M.Suzuki, Y.Nakata, H. Nagai, K. Goto, O. Nishimura, T. Okutani,
Mater. Sci.Engineer. A146(1998)36

laser CVD

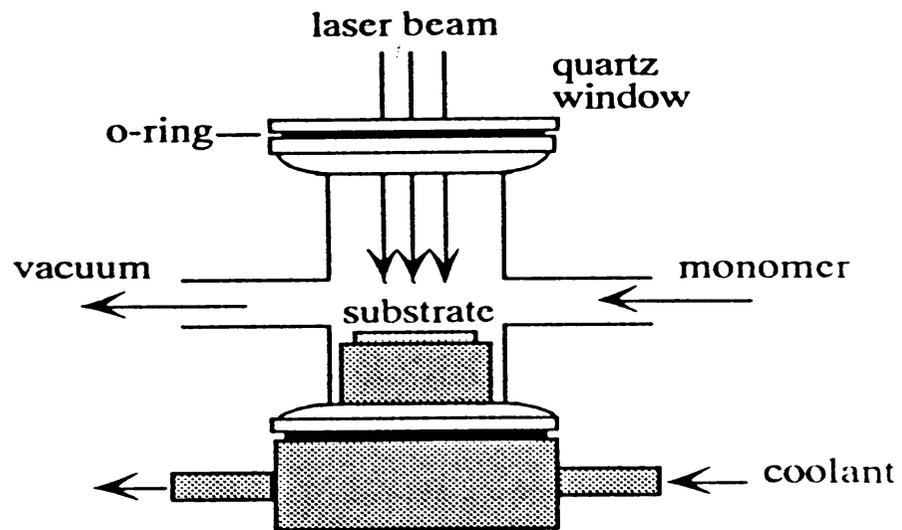

Fig. 2. Apparatus of laser CVD.

A . Watanabe, T.Kawato, M. Matsuda, M. Fujitsuka, O. Ito, Thin Sol Films, 312(1998)123

RFdischarge

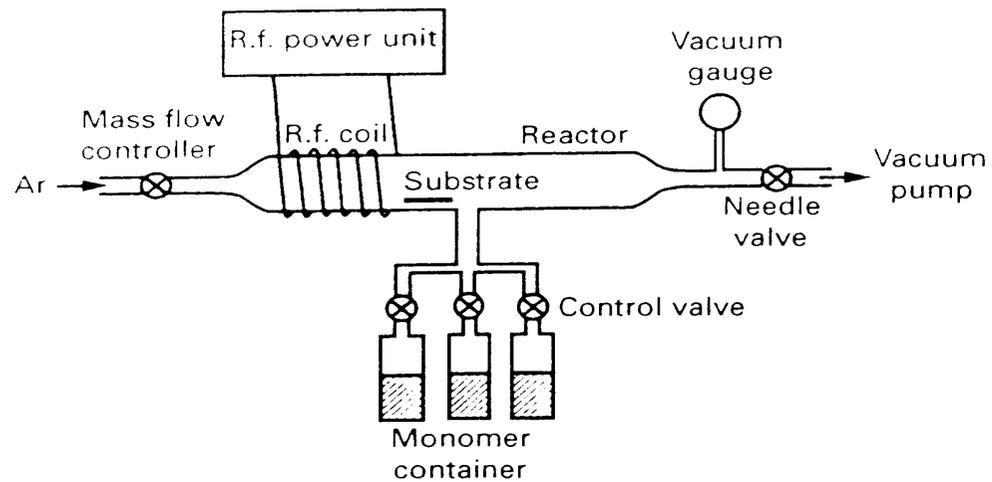
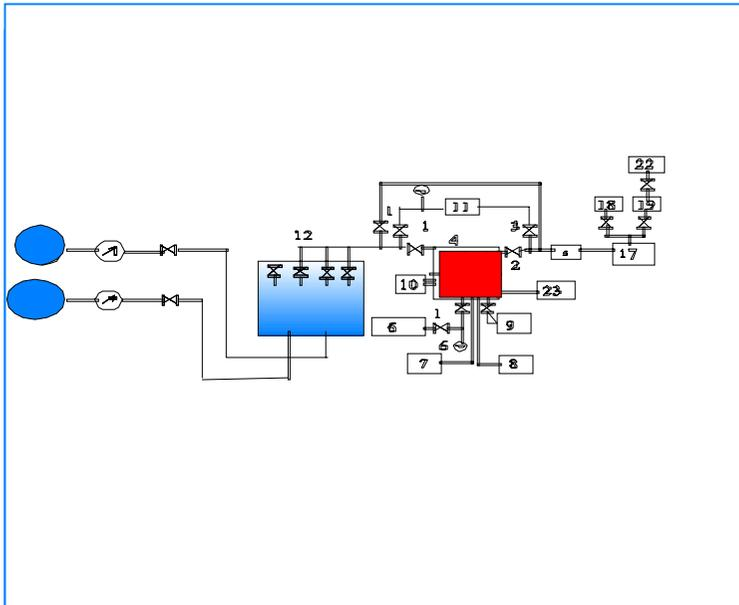

Figure 1 Schematic diagram of the reactor system.

PLASMA TECHNIQUES USED

Radio Frequency Plasma Enhanced CVD



Microwave Frequency Plasma Enhanced CVD

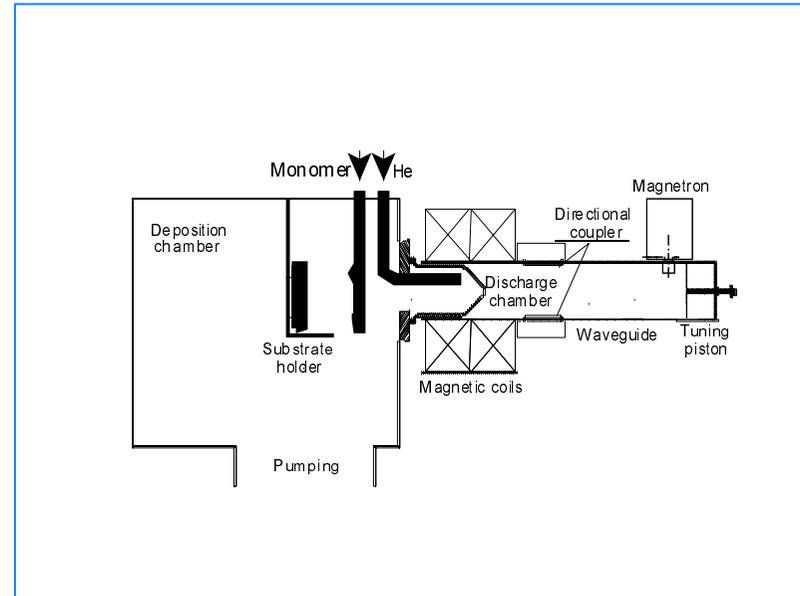

Plasma polysilylenes - luminescence vs conditions

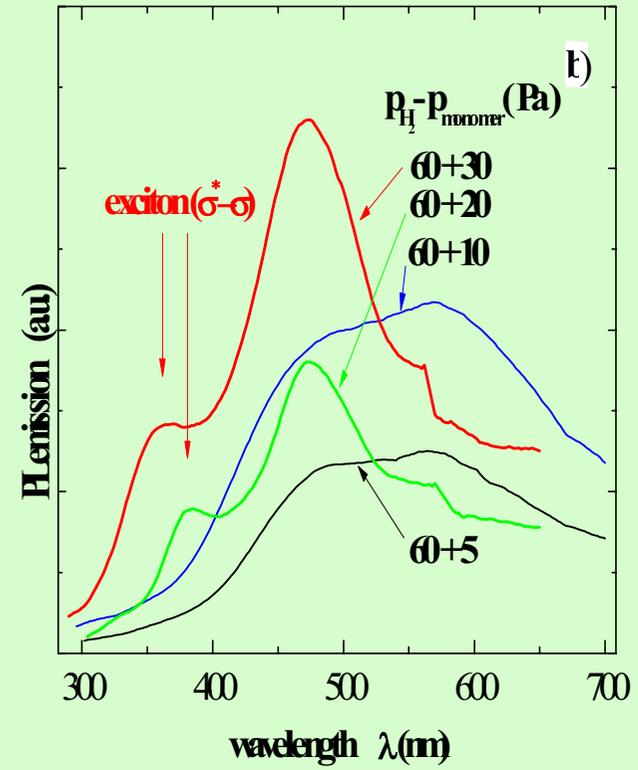
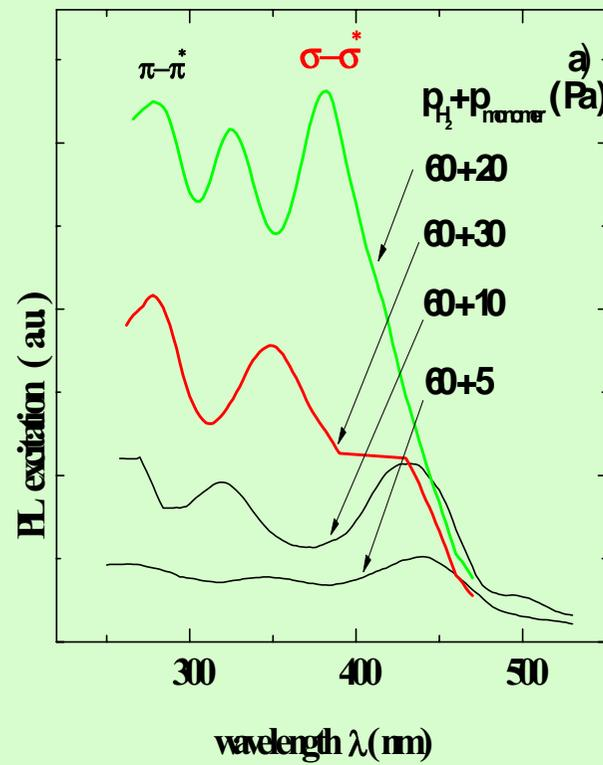

Micro wave plasma - luminescence

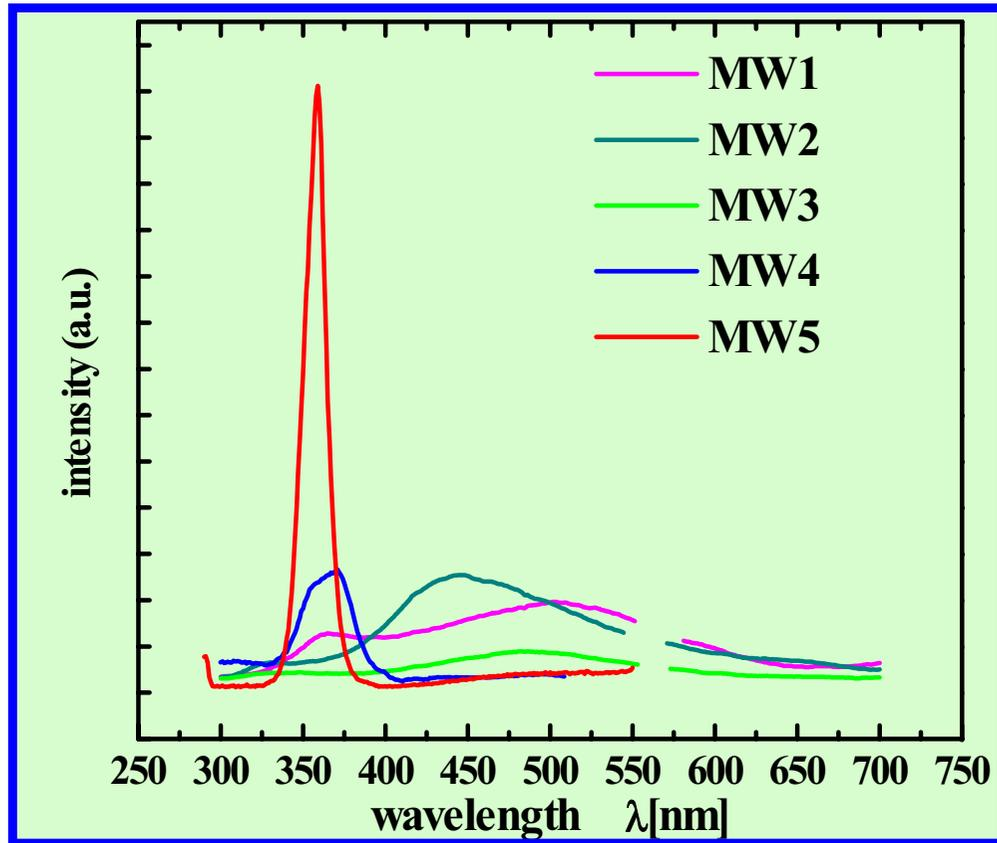

sample	flow rate of H2 (sccm)/ pressure of H2 (Pa)	deposition pressure (Pa)	partial pressure of monomer (Pa)	substrate temperature (K)
MW1	15/14	19	5	320 - 350
MW2	15/18	30	12	"
MW3	15/18	20	2	"
MW4	40/0.080	0.085	0.005	390 - 410
MW5	40/0.100	0.130	0.030	360 - 390

Radiofrequency plasma - luminescence



This work is supported by European Commission programme COST 518

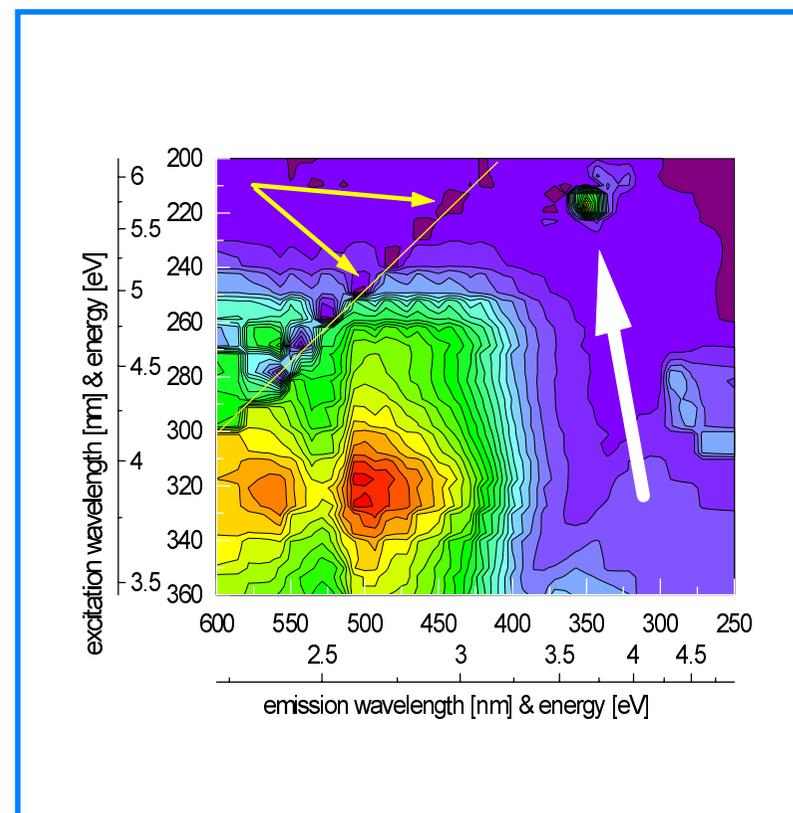
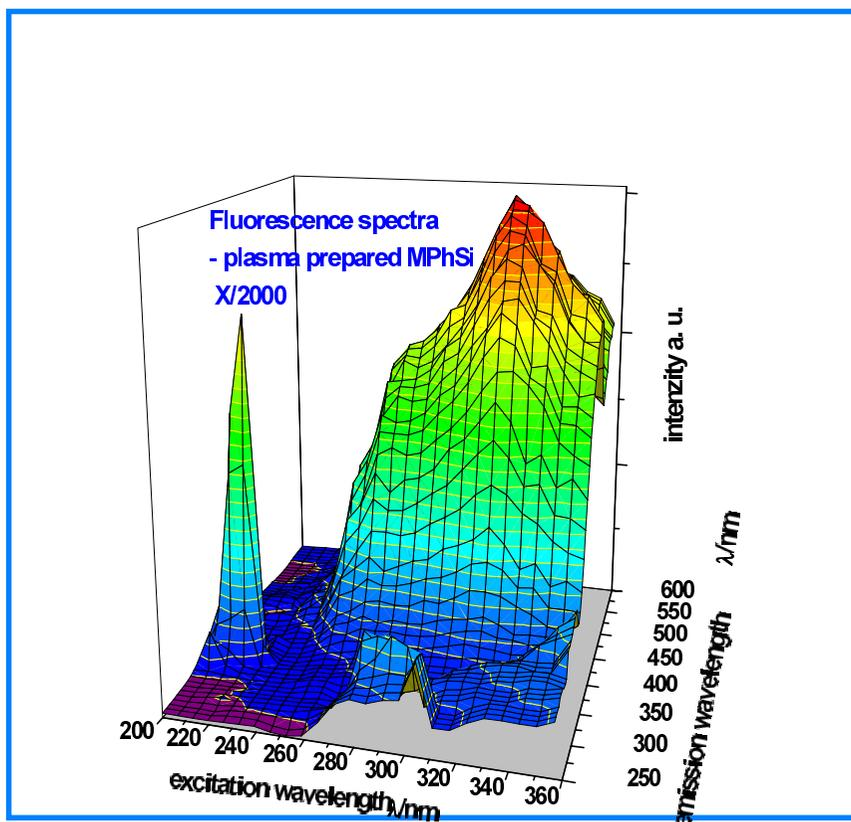

P.Horvath, F.Schauer, I.Kuritka, O.Salyk, M.Weiter, N.Dokoupil, S.Nespurek and V. Fidler: Luminescence in organic silicon prepared from organic precursors in plasma discharges, *Chemical Monthly* 132(2001),177-184 ,

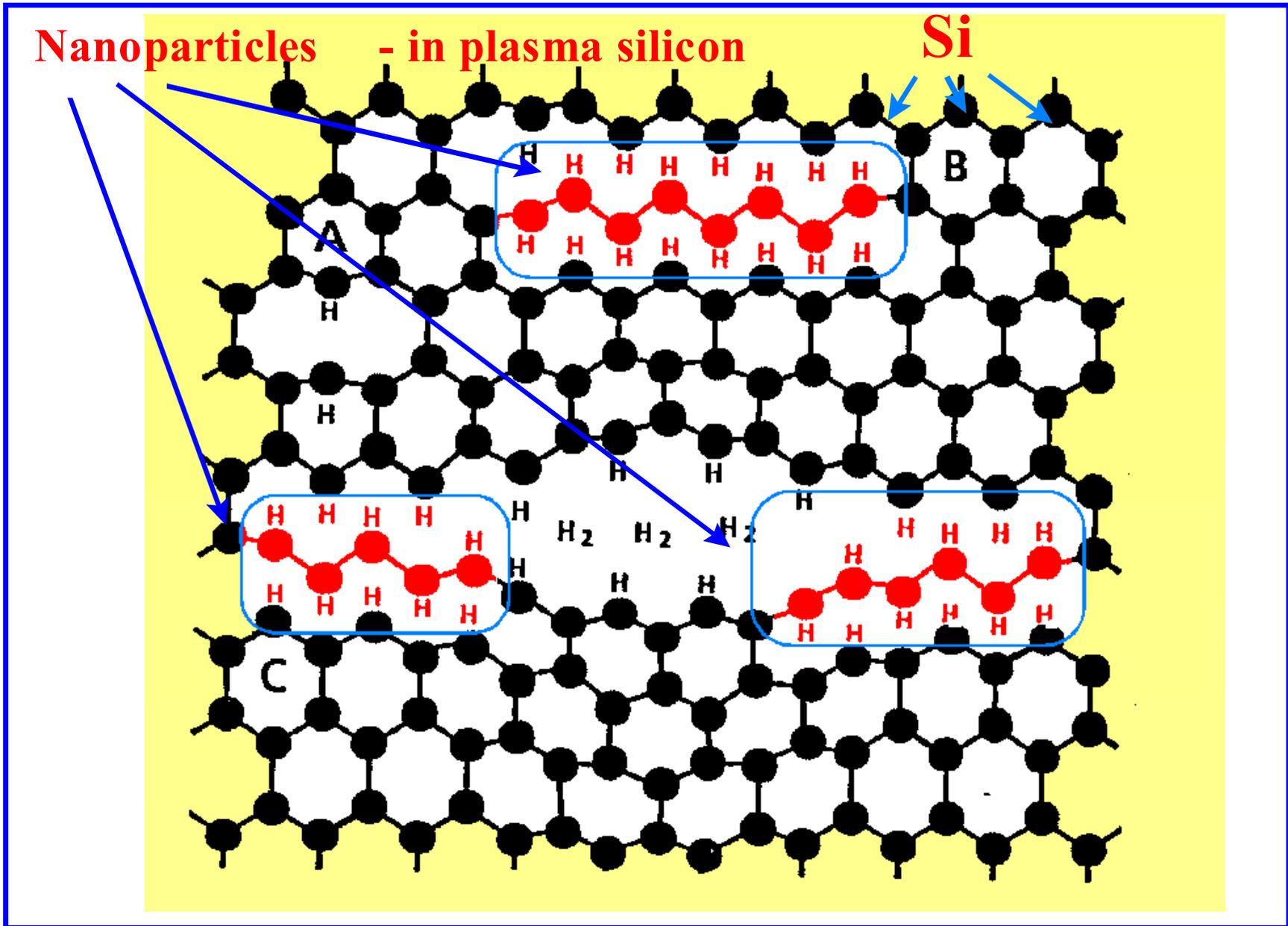

5. Degradace, metastabilita vs fotorezisty

Degradation of luminescence in PMPSi

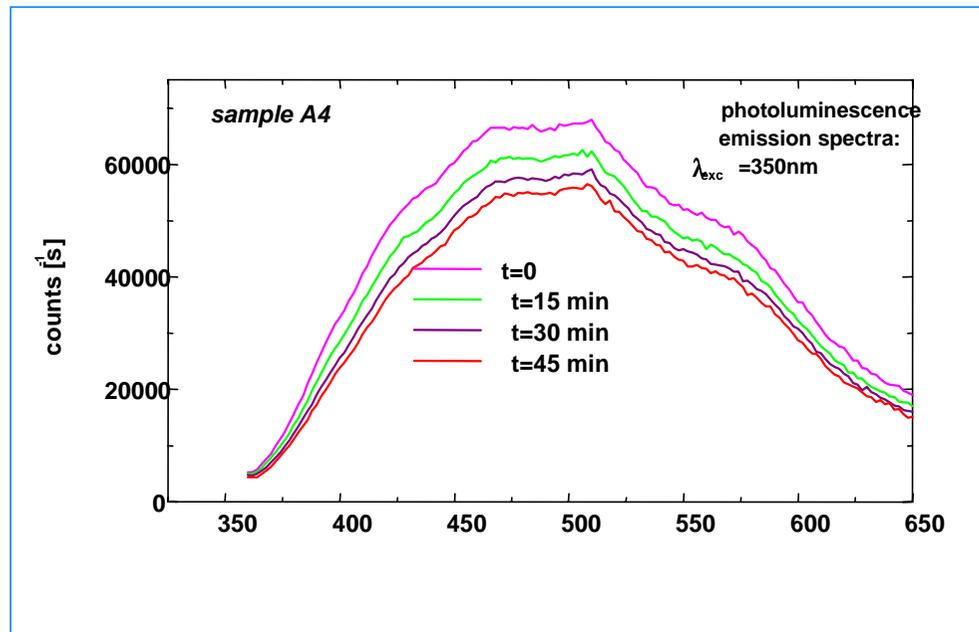
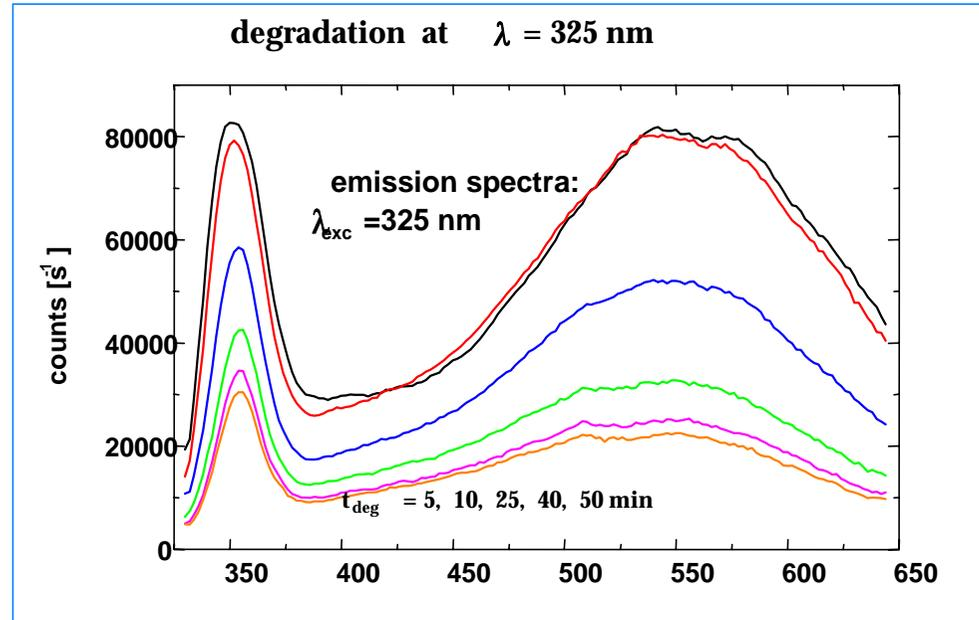
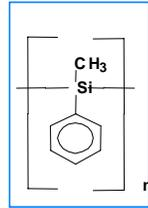

Degradation of luminescence in PMPSi

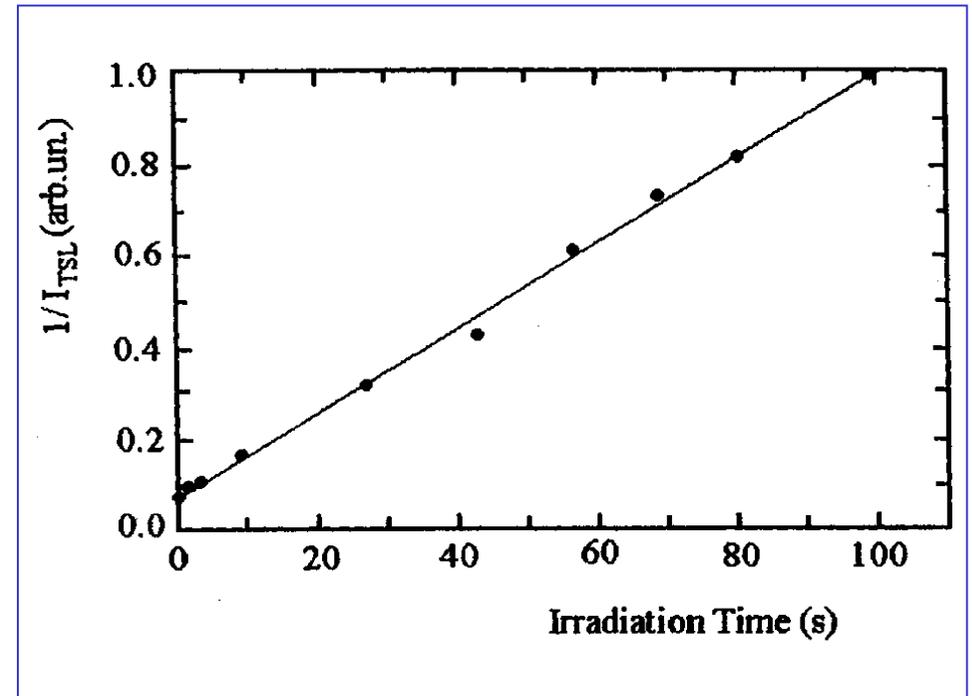
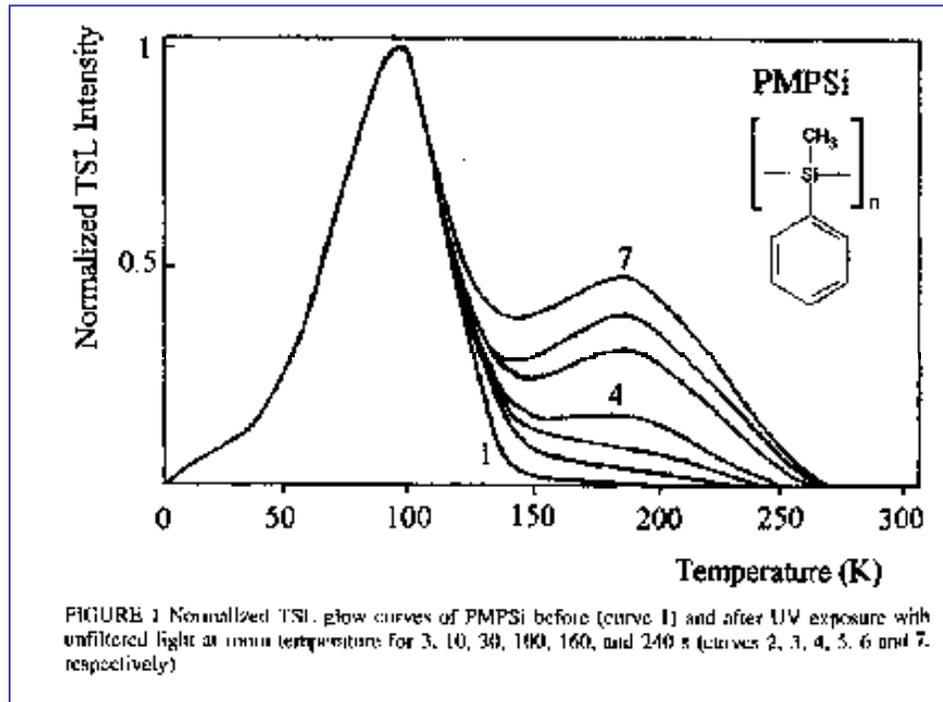

Degradation of transport in PMPSi

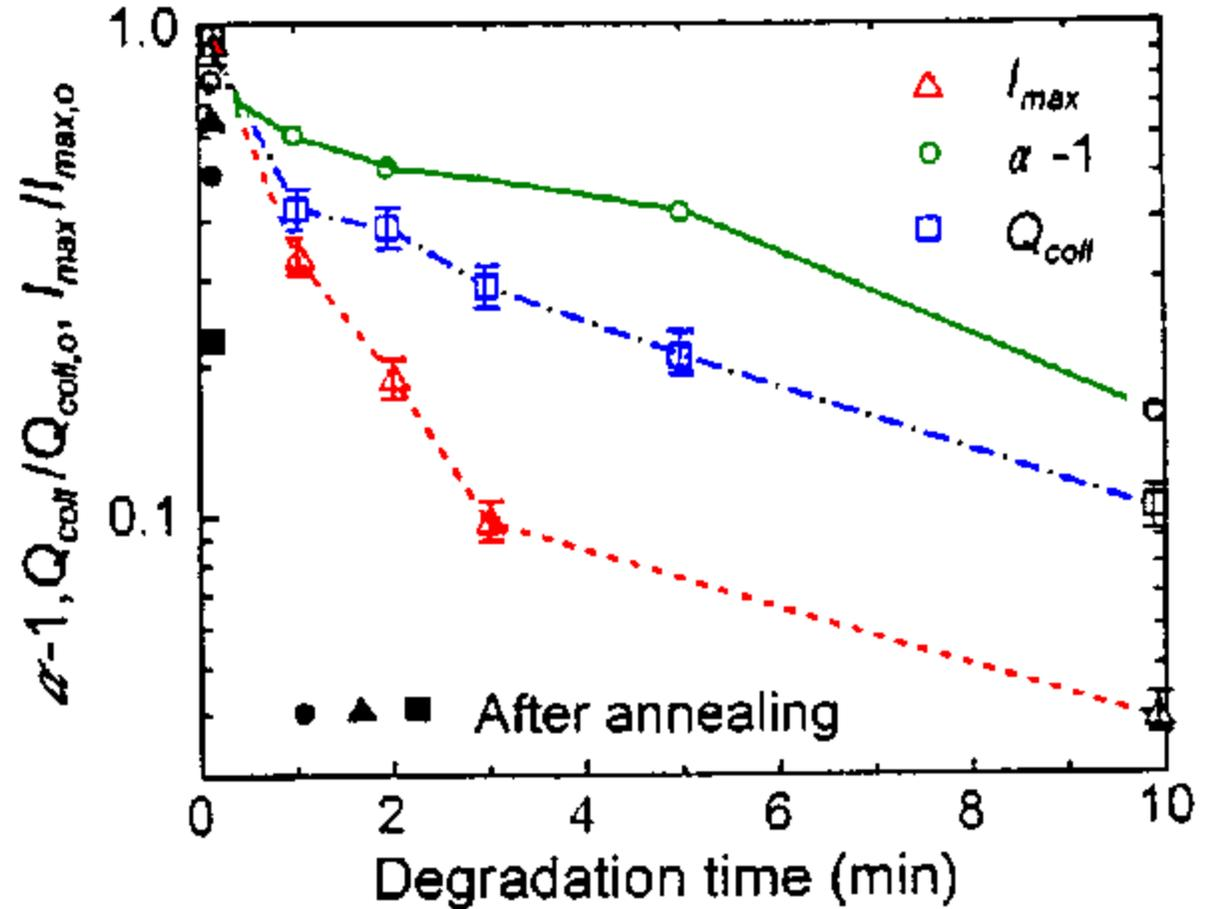

Degradation of cathodoluminescence in PMPSi

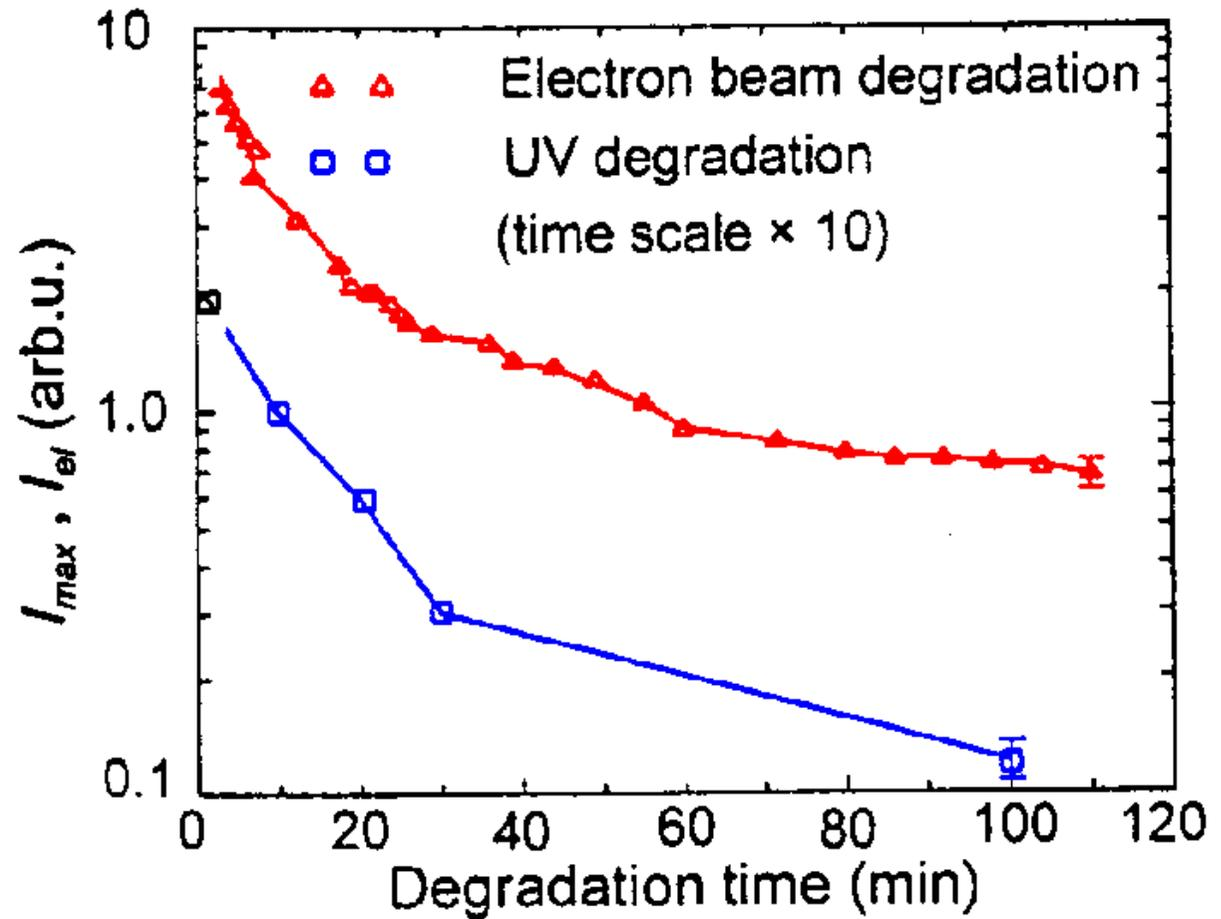

R. Handlíř, F. Schauer, S. Nešpůrek, I. Kuřitka, M. Weiter, and P. Schauer: Meta-stability in poly(methylsilylene) induced by UV radiation and electron beam, *J. Non-Crystall. Solids (Hol.)* 227-230 (1998), 669,

Molecular weight degradation in PMPSi

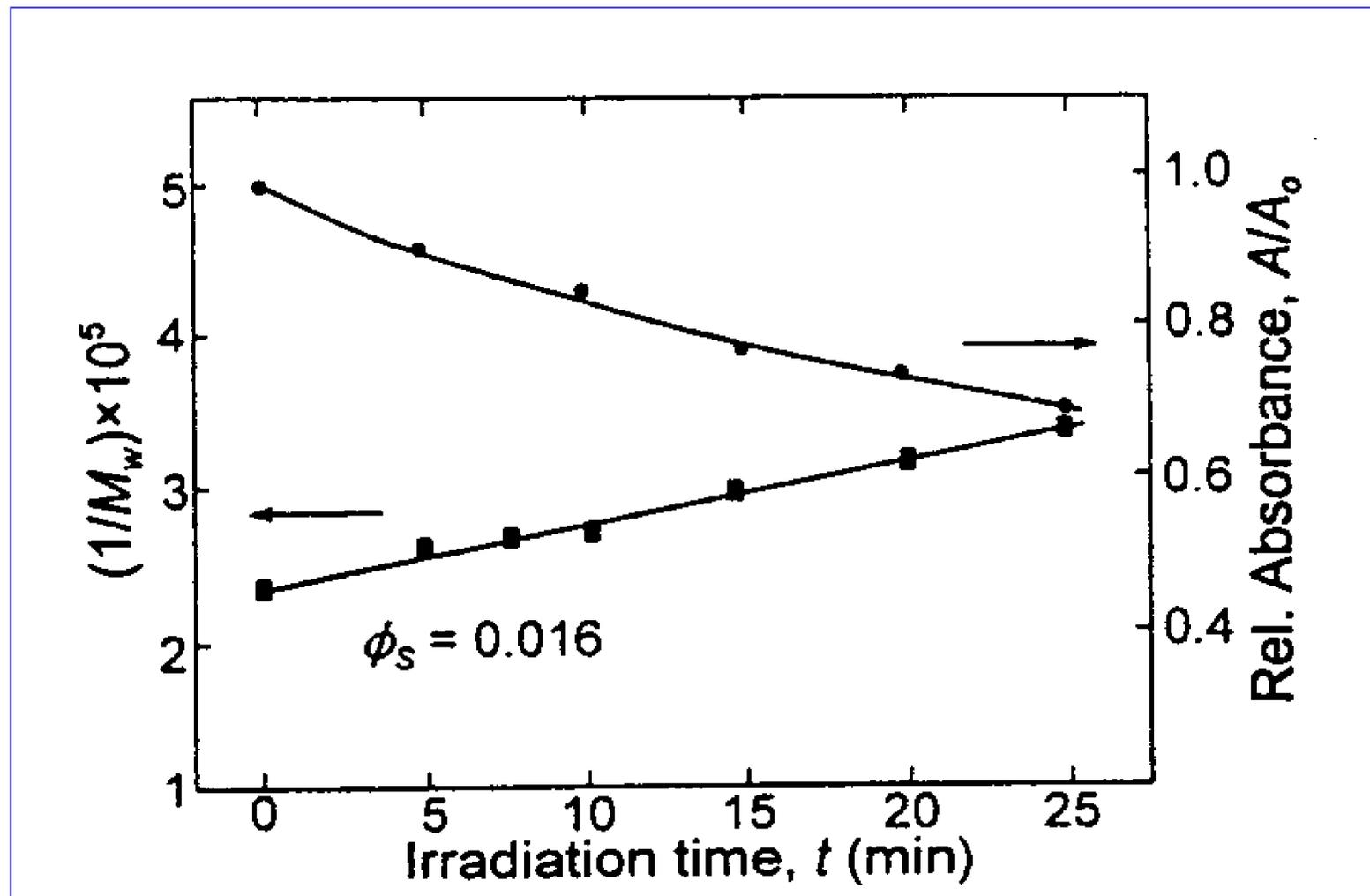

Degradation of PMPSi

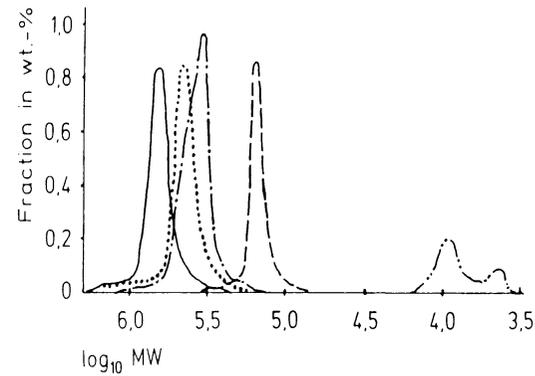
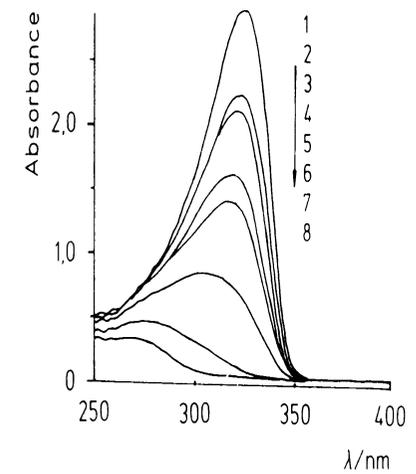

Fig. 5. Change in molecular weight distribution of PCHMS in cyclohexane solutions ($\approx 10^{-4} \text{ mol} \cdot \text{L}^{-1}$) upon UV irradiation in air. (—): Original polymer; (· · ·): after irradiation for 4 s; (- · -): 8 s; (- - -): 15 s; (- - - -): 30 s

Deben Chen and Huiping Hu, Studies on the behaviour of photodegradation of poly(cyclohexylmethylsilane),
Macromol. Chem. Phys. 195 (1994), 2981

Fig. 3. Ultraviolet spectra of PCHMS in cyclohexane solutions ($\approx 10^{-4} \text{ mol} \cdot \text{L}^{-1}$) before and after UV irradiation in air. (1) 0 s; (2) 2 s; (3) 6 s; (4) 10 s; (5) 12 s; (6) 15 s; (7) 30 s; (8) 1 min



Metastability in luminescence - PMPSi

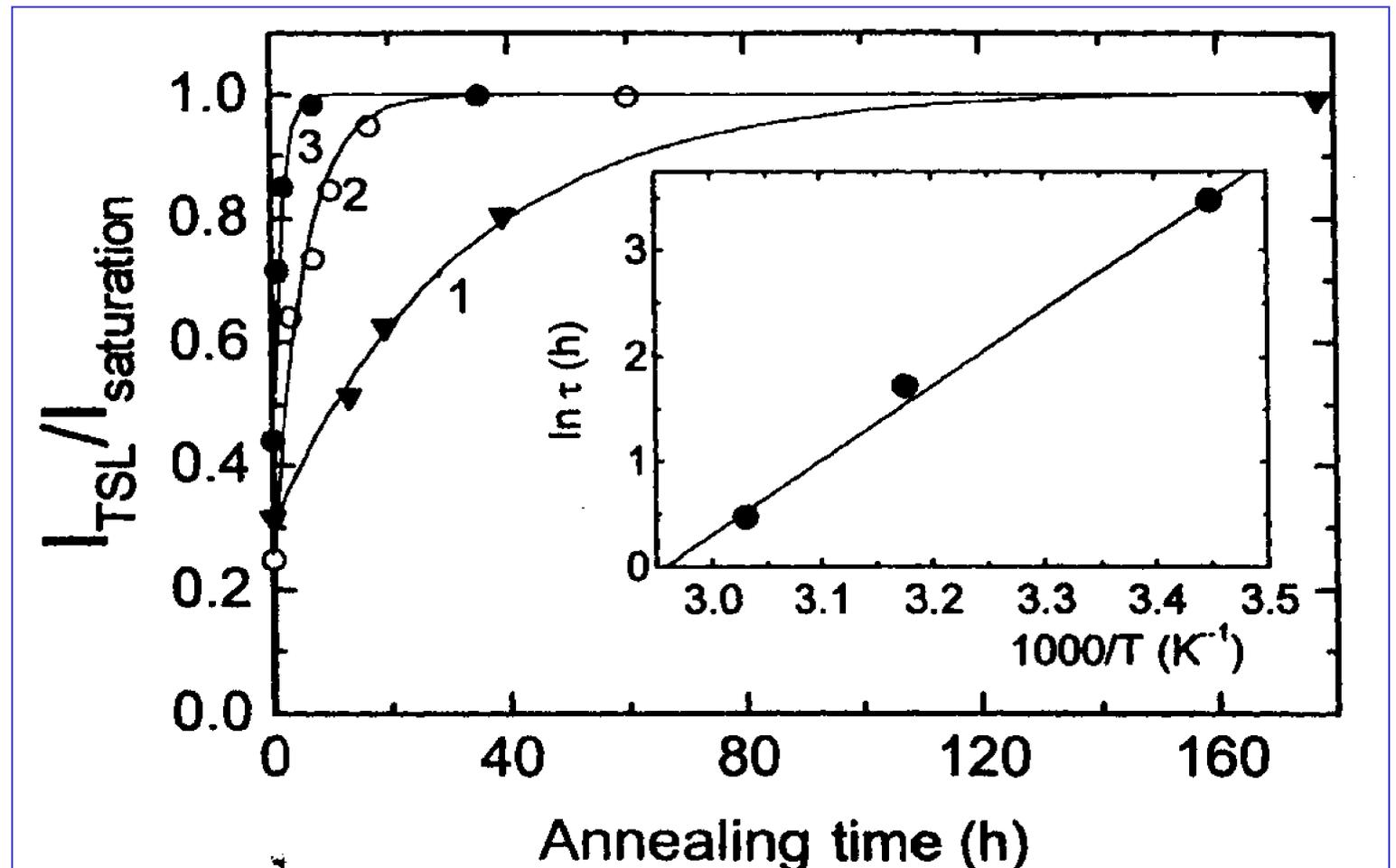

Nanostructural model

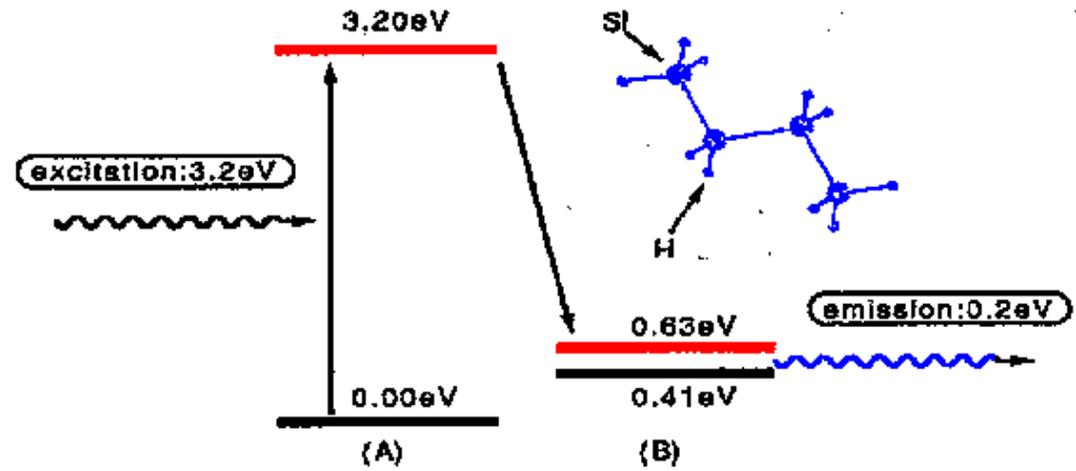
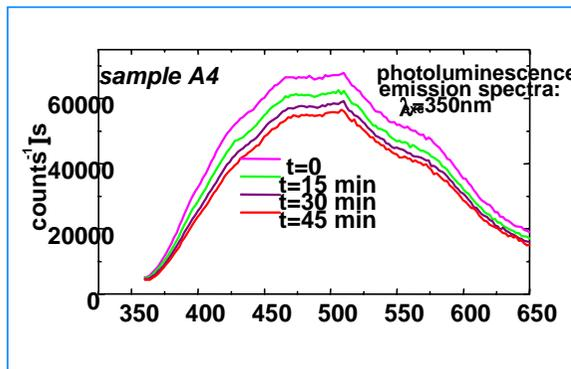

(a) Si₄H₁₀ (trans planar type)

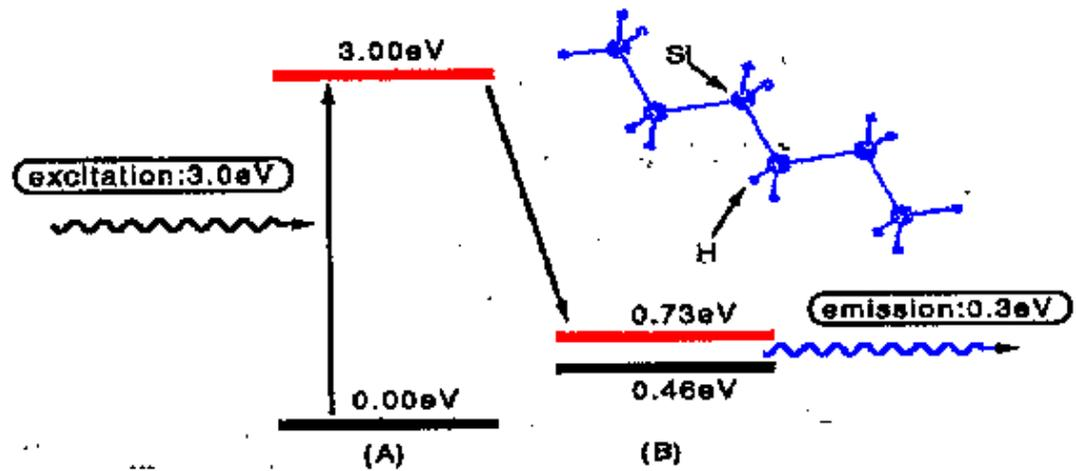

(b) Si₆H₁₄ (trans planar type)

Nanostructural model

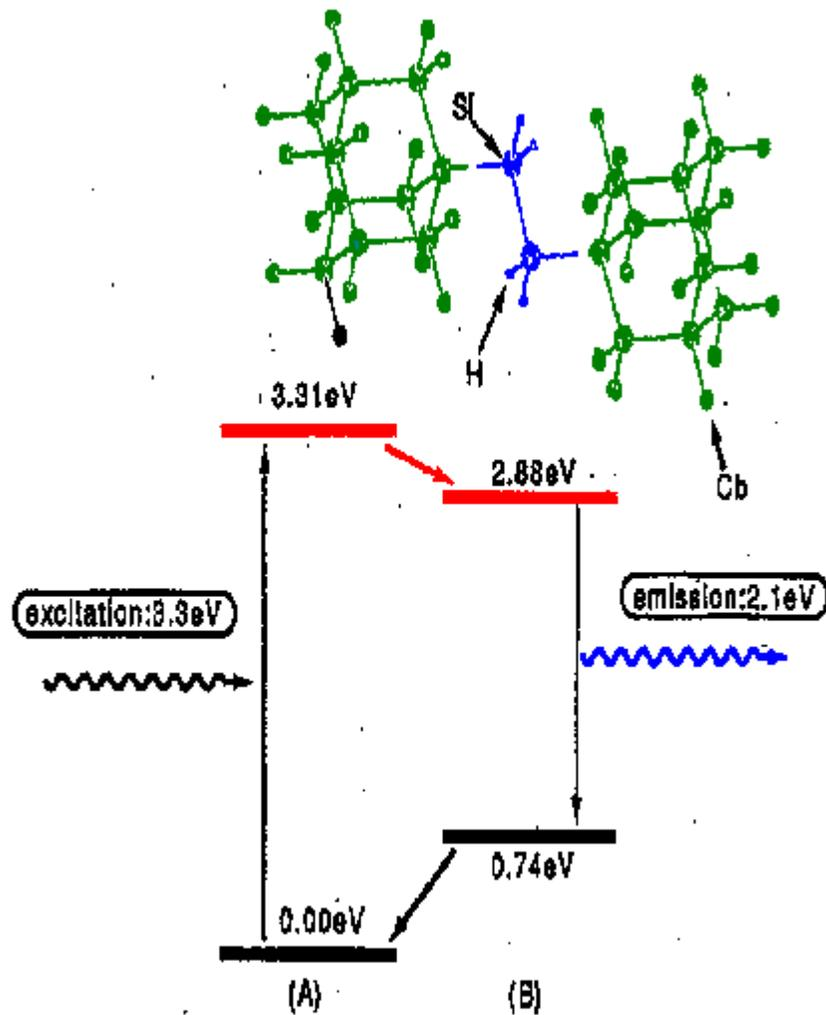

(a) $\text{Si}_{10}\text{Cb}_{15}-\text{Si}_2\text{H}_4-\text{Si}_{10}\text{Cb}_{15}$ (Cb: capped bond)

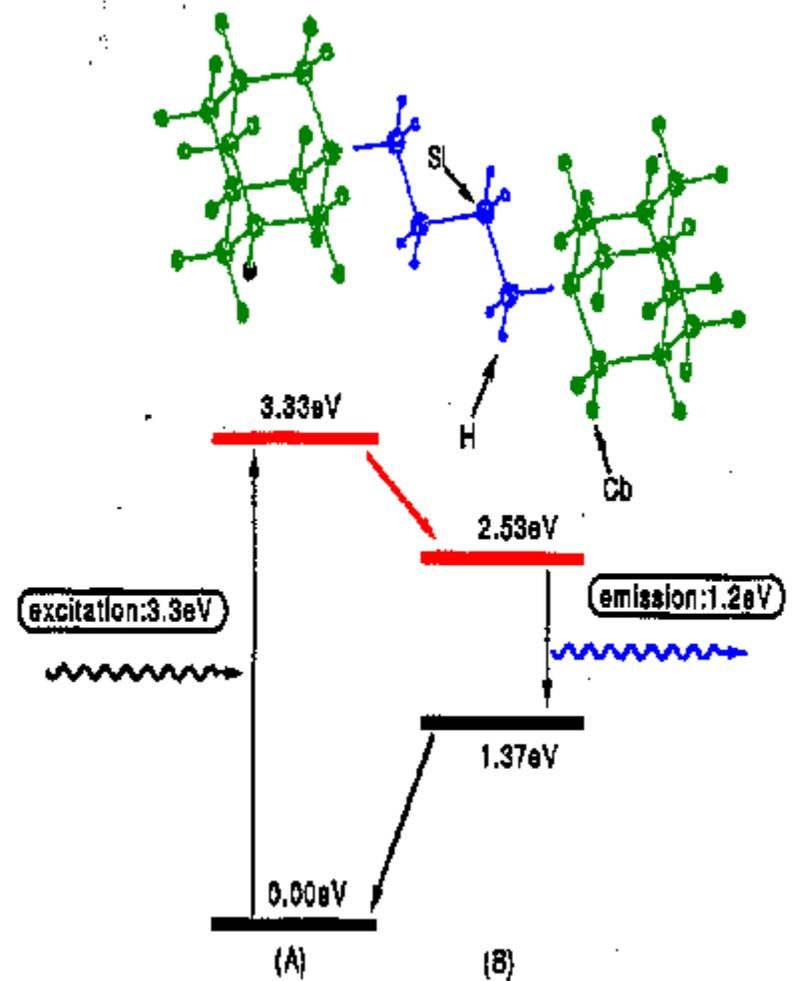

(b) $\text{Si}_{10}\text{Cb}_{15}-\text{Si}_4\text{H}_8-\text{Si}_{10}\text{Cb}_{15}$ (Cb: capped bond)

Závěrem



F. Schauer