

# On the Coderivative of the Projection Operator onto the Second-order Cone

Jiří V. Outrata · Defeng Sun

Received: 11 February 2008 / Accepted: 7 May 2008 /  
Published online: 19 June 2008  
© Springer Science + Business Media B.V. 2008

**Abstract** The limiting (Mordukhovich) coderivative of the metric projection onto the second-order cone  $\mathbb{R}^n$  is computed. This result is used to obtain a sufficient condition for the Aubin property of the solution map of a parameterized second-order cone complementarity problem and to derive necessary optimality conditions for a mathematical program with a second-order cone complementarity problem among the constraints.

**Keywords** Second-order cone · Projection · Limiting coderivative · Aubin property

**Mathematics Subject Classifications (2000)** Primary: 49J52 · 49J53 · Secondary: 58C06 · 90C46

---

The research of J.V. Outrata was supported by the grant IAA 100750802 of the Grant Agency of the Academy of Sciences of the Czech Republic.

The research of D. Sun was supported by the Academic Research Fund under Grant R-146-000-104-112 and the Risk Management Institute under Grants R-703-000-004-720 and R-703-000-004-646, National University of Singapore.

---

J. V. Outrata (✉)  
Institute of Information Theory and Automation,  
Academy of Sciences of the Czech Republic,  
18208 Prague, Czech Republic  
e-mail: outrata@utia.cas.cz.

D. Sun  
Department of Mathematics and Risk Management Institute,  
National University of Singapore, 2 Science Drive 2,  
Kent Ridge, Republic of Singapore  
e-mail: matsundf@nus.edu.sg

### 1 Introduction

There are a lot of optimization and equilibrium problems whose constraints involve the so-called second-order (or Lorentz) cone defined by

$$\mathcal{K}^n := \{y \in \mathbb{R}^n \mid y_n \geq \|y'\|_2\},$$

where  $y' = (y_1, y_2, \dots, y_{n-1})$  and  $\|\cdot\|_2$  stands for the Euclidean norm, cf. [12]. As a representative problem of this kind one can consider eg a discretized 3D contact problem with given friction [8] or optimization of grasp forces in robotics [12]. Concerning stability and sensitivity issues, there are quite a number of recent important results, partially associated with the development of various numerical methods. Let us mention, for instance, the papers [3, 6], where an explicit representation of the projection onto  $\mathcal{K}^n$  and its directional derivative is derived and the strong semismoothness of the projection is shown. In [17] one finds important results about strong regularity [18] accompanied with application to second-order cone complementarity problems. Nevertheless, there are still a lot of open problems in this area, for instance in connection with the Aubin property [1] of parameterized variational inequalities/complementarity problems with second-order cone constraints.

The main aim of this paper is to compute the limiting (Mordukhovich) coderivative of the metric projection onto  $\mathcal{K}^n$ , which is an important step towards the analysis of the Aubin property in this environment. This is done in Section 2 on the basis of the results from [3, 6], concerning directional derivatives and Clarke generalized Jacobians of the projection map. Similarly to [6] and [3], we benefit in our analysis from strong results, valid in Jordan algebras on symmetric cones, cf. eg [5, 9] and [10]. The second part of the paper (Section 3) is then devoted to an analysis of the Aubin property of a second-order cone complementarity problem. The obtained results lead, among others, to efficient (selective) necessary optimality conditions for a mathematical program with equilibrium constraints, where the equilibrium is governed by a second-order cone complementarity problem.

Our notation is basically standard. For a function  $f$ ,  $f'$  denotes its (Fréchet) derivative. If  $f$  depends on two variables, say  $x, y$ , then  $f'_x, f'_y$  denote the partial derivatives of  $f$  with respect to  $x, y$ , respectively. For a closed convex set  $\Omega$ ,  $\text{Proj}_\Omega(\cdot)$  is the metric projector onto  $\Omega$ . Finally,  $\mathbb{B}$  denotes the closed unit ball, and  $I$  stands for the unit matrix.

Throughout the paper we extensively use the following notions of the generalized differential calculus of Mordukhovich [16].

Given a closed set  $A \subset \mathbb{R}^n$  and a point  $\bar{x} \in A$ , we denote by  $\widehat{N}_A(\bar{x})$  the *Fréchet (regular) normal cone* to  $A$  at  $\bar{x}$ , defined by

$$\widehat{N}_A(\bar{x}) := \left\{ x^* \in \mathbb{R}^n \mid \limsup_{x \xrightarrow{A} \bar{x}} \frac{\langle x^*, x - \bar{x} \rangle}{\|x - \bar{x}\|} \leq 0 \right\}.$$

The *limiting (Mordukhovich) normal cone* to  $A$  at  $\bar{x}$ , denoted  $N_A(\bar{x})$ , is defined by

$$N_A(\bar{x}) := \text{Lim sup}_{x \xrightarrow{A} \bar{x}} \widehat{N}_A(x),$$

where “Lim sup” is the Painlevé-Kuratowski outer limit of sets (see [19]). If  $A$  is convex, then  $N_A(\bar{x}) = \widehat{N}_A(\bar{x})$  amounts to the classic normal cone in the sense of convex analysis.

On the basis of the above notions, we can also describe the local behaviour of multifunctions. Let  $\Phi: \mathbb{R}^n \rightrightarrows \mathbb{R}^m$  be a multifunction with its graph being closed and  $(\bar{x}, \bar{y}) \in \text{Graph } \Phi$ . The multifunction  $\widehat{D}^* \Phi(\bar{x}, \bar{y}) : \mathbb{R}^m \rightrightarrows \mathbb{R}^n$ , defined by

$$\widehat{D}^* \Phi(\bar{x}, \bar{y})(y^*) := \{x^* \in \mathbb{R}^n \mid (x^*, -y^*) \in \widehat{N}_{\text{Graph } \Phi}(\bar{x}, \bar{y})\}$$

is called *regular coderivative* of  $\Phi$  at  $(\bar{x}, \bar{y})$ . Analogously, the multifunction  $D^* \Phi(\bar{x}, \bar{y}) : \mathbb{R}^m \rightrightarrows \mathbb{R}^n$ , defined by

$$D^* \Phi(\bar{x}, \bar{y})(y^*) := \{x^* \in \mathbb{R}^n \mid (x^*, -y^*) \in N_{\text{Graph } \Phi}(\bar{x}, \bar{y})\}$$

is called *limiting (Mordukhovich) coderivative* of  $\Phi$  at  $(\bar{x}, \bar{y})$ . If  $\Phi$  happens to be single-valued, we usually write  $\widehat{D}^* \Phi(\bar{x})(D^* \Phi(\bar{x}))$ . If  $\Phi$  is continuously differentiable, then  $\widehat{D}^* \Phi(\bar{x}) = D^* \Phi(\bar{x})$  amounts to the adjoint Jacobian of  $\Phi$  at  $\bar{x}$ .

In addition, for a single-valued Lipschitz continuous mapping  $F: \mathbb{R}^n \rightarrow \mathbb{R}^m$ , we will also employ the *B-subdifferential*  $\bar{\partial}_B F$ , defined by

$$\bar{\partial}_B F(x) := \left\{ \lim_{i \rightarrow \infty} F'(x_i) \mid x_i \rightarrow x, F \text{ is differentiable at } x_i \right\}.$$

The convex hull of  $\bar{\partial}_B F(x)$  amounts to the *Clarke generalized Jacobian* of  $F$  at  $x$ , denoted here by  $\bar{\partial} F(x)$ , cf. [4].

## 2 Computation of the Coderivative

For the purpose of studying the limiting coderivative of the metric projection operator onto  $\mathcal{K}^n$ , we need some knowledge about Euclidean Jordan algebras, which can be found from the standard references [5, 9].

For any  $x = (x^t, x_n)$  and  $y = (y^t, y_n) \in \mathbb{R}^{n-1} \times \mathbb{R}$ , the *Jordan product* between  $x$  and  $y$  is defined as

$$x \circ y := \begin{pmatrix} x_n y^t + y_n x^t \\ x^T y \end{pmatrix} = L(x)y, \tag{2.1}$$

where

$$L(x) := \begin{bmatrix} x_n I & x^t \\ (x^t)^T & x_n \end{bmatrix}.$$

The inner product between  $x$  and  $y$  used here is  $\langle x, y \rangle := 2x^T y$ . For any  $z \in \mathbb{R}^n$ , let  $S(z) := \text{Proj}_{\mathcal{K}^n}(z)$  be the metric projection of  $z$  onto the second-order cone  $\mathcal{K}^n$  with respect to this inner product. For any  $s \in \mathbb{R}$ , we let  $s_+ := \max(0, s)$  and  $s_- := \min(0, s)$ .

Let  $z \in \mathbb{R}^n$ . Then we know from [5] that  $z$  has the following spectral decomposition

$$z = \lambda_1(z)c_1(z) + \lambda_2(z)c_2(z), \tag{2.2}$$

where for  $i = 1, 2$ ,

$$\lambda_i(z) = z_n + (-1)^i \|z^t\|_2$$

and

$$c_i(z) = \begin{cases} 1/2 \left( (-1)^i \frac{z^t}{\|z^t\|_2}, 1 \right)^T & \text{if } z^t \neq 0, \\ 1/2 \left( (-1)^i w, 1 \right)^T & \text{if } z^t = 0, \end{cases}$$

where  $w$  is any vector in  $\mathbb{R}^{n-1}$  satisfying  $\|w\|_2 = 1$ . Then,  $S(z)$  can be written as

$$S(z) = (\lambda_1(z))_+ c_1(z) + (\lambda_2(z))_+ c_2(z).$$

Note that the *determinant* of  $z$  is given by  $\det(z) = \lambda_1(z)\lambda_2(z) = (z_n)^2 - \|z^t\|_2^2$ . For a short introduction on the spectral decomposition (2.2), see [6].

Define  $f: \mathbb{R} \rightarrow \mathbb{R}_+$  by

$$f(t) := t_+ = \max(0, t), \quad t \in \mathbb{R}.$$

For any  $\lambda \in \mathbb{R}^2$  with  $\lambda_1\lambda_2 \neq 0$ , denote the first divided difference matrix of  $f$  at  $\lambda$  by

$$[f^{[1]}(\lambda)]_{ij} = \begin{cases} \frac{f(\lambda_i) - f(\lambda_j)}{\lambda_i - \lambda_j} & \text{if } \lambda_i \neq \lambda_j, \\ f'(\lambda_i) & \text{if } \lambda_i = \lambda_j, \end{cases} \quad i, j = 1, 2.$$

Then, by Koranyi [10] we know that for any  $z \in \mathbb{R}^n$  with  $\det(z) \neq 0$ ,  $S$  is (Fréchet) differentiable at  $z$  with

$$S'(z)h = \sum_{i=1}^2 [f^{[1]}(\lambda(z))]_{ii} (c_i(z), h)c_i(z) + 4 [f^{[1]}(\lambda(z))]_{12} c_1(z) \circ [c_2(z) \circ h] \quad \forall h \in \mathbb{R}^n, \tag{2.3}$$

which implies that

$$\begin{aligned} S'(z) &= 2 \sum_{i=1}^2 [f^{[1]}(\lambda(z))]_{ii} c_i(z)(c_i(z))^T + 4 [f^{[1]}(\lambda(z))]_{12} L(c_1(z))L(c_2(z)) \\ &= 2 \sum_{i=1}^2 [f^{[1]}(\lambda(z))]_{ii} c_i(z) (c_i(z))^T + [f^{[1]}(\lambda(z))]_{12} \begin{bmatrix} I - ww^T & 0 \\ 0 & 0 \end{bmatrix}, \end{aligned} \tag{2.4}$$

where if  $z^t \neq 0$ , then  $w = z^t/\|z^t\|_2$  and otherwise  $w$  is any vector in  $\mathbb{R}^{n-1}$  such that  $\|w\|_2 = 1$ . It can be checked directly from (2.3) and (2.4) that  $S$  is actually continuously differentiable around  $z \in \mathbb{R}^n$  if  $\det(z) \neq 0$ . This allows one to compute the B-subdifferential  $\bar{\partial}_B S(\cdot)$  of the metric projector  $S(\cdot)$ , which has been discussed in several papers [2, 7, 11, 17].

**Lemma 1** *Let  $z \in \mathbb{R}^n$  have the spectral decomposition as in (2.2). It holds that*

- (i) *if  $\det(z) \neq 0$ , then*

$$\bar{\partial}_B S(z) = \{S'(z)\}.$$

(ii) if  $\det(z) = 0$  but  $\lambda_2(z) \neq 0$ , i.e.,  $z \in \text{bd } \mathcal{K}^n \setminus \{0\}$ , then

$$\bar{\partial}_B S(z) = \left\{ I, I + 1/2 \begin{bmatrix} -\frac{z^t(z^t)^T}{\|z^t\|_2^2} & \frac{z^t}{\|z^t\|_2} \\ \frac{(z^t)^T}{\|z^t\|_2} & -1 \end{bmatrix} \right\}.$$

(iii) if  $\det(z) = 0$  but  $\lambda_1(z) \neq 0$ , i.e.,  $z \in \text{bd } (-\mathcal{K}^n) \setminus \{0\}$ , then

$$\bar{\partial}_B S(z) = \left\{ 0, 1/2 \begin{bmatrix} \frac{z^t(z^t)^T}{\|z^t\|_2^2} & \frac{z^t}{\|z^t\|_2} \\ \frac{(z^t)^T}{\|z^t\|_2} & 1 \end{bmatrix} \right\}.$$

(iv) if  $\det(z) = 0$  and  $\lambda_1(z) = \lambda_2(z) = 0$ , i.e.,  $z = 0$ , then

$$\bar{\partial}_B S(z) = \{I, 0\} \cup \left\{ 1/2 \begin{bmatrix} 2\alpha I + (1 - 2\alpha)ww^T & w \\ w^T & 1 \end{bmatrix} \mid w \in \mathbb{R}^{n-1}, \|w\|_2 = 1, \alpha \in [0, 1] \right\}. \tag{2.5}$$

From [3], we have the following result on the directional derivative of  $S(\cdot)$ .

**Lemma 2** *Let  $z \in \mathbb{R}^n$  have the spectral decomposition as in (2.2). The function  $S(\cdot)$  is directionally differentiable at  $z$  and for any  $h \in \mathbb{R}^n$ ,*

(i) if  $\det(z) \neq 0$ , then

$$S'(z; h) = S'(z)h.$$

(ii) if  $\det(z) = 0$  but  $\lambda_2(z) \neq 0$ , i.e.,  $z \in \text{bd } \mathcal{K}^n \setminus \{0\}$ , then

$$S'(z; h) = h - 2((c_1(z))^T h)_- c_1(z).$$

(iii) if  $\det(z) = 0$  but  $\lambda_1(z) \neq 0$ , i.e.,  $z \in \text{bd } (-\mathcal{K}^n) \setminus \{0\}$ , then

$$S'(z; h) = 2((c_2(z))^T h)_+ c_2(z).$$

(iv) if  $\det(z) = 0$  and  $\lambda_1(z) = \lambda_2(z) = 0$ , i.e.,  $z = 0$ , then

$$S'(z; h) = S(h).$$

Since  $S(\cdot)$  is Lipschitz continuous and directionally differentiable, it follows from [21] that  $S(\cdot)$  is Bouligand differentiable in the sense that for  $\mathbb{R}^n \ni h \rightarrow 0$ ,

$$S(z + h) - S(z) - S'(z; h) = o(\|h\|).$$

Thus, from the Lipschitz continuity of  $S(\cdot)$  and definition of the Fréchet coderivative  $\widehat{D}^* S(z)$ , we know that for  $u^* \in \mathbb{R}^n$ ,

$$z^* \in \widehat{D}^* S(z)(u^*) \iff \langle z^*, h \rangle \leq \langle u^*, S'(z; h) \rangle \quad \forall h \in \mathbb{R}^n. \tag{2.6}$$

Therefore, by Lemma 2, we obtain the following characterization of the Fréchet coderivative  $\widehat{D}^* S(z)$ .

**Theorem 1** Let  $z \in \mathbb{R}^n$  have the spectral decomposition as in (2.2). Let  $u^* \in \mathbb{R}^n$ . It holds that

(i) if  $\det(z) \neq 0$ , then

$$\widehat{D}^*S(z)(u^*) = \{S'(z)u^*\}.$$

(ii) if  $\det(z) = 0$  but  $\lambda_2(z) \neq 0$ , i.e.,  $z \in \text{bd } \mathcal{K}^n \setminus \{0\}$ , then

$$\widehat{D}^*S(z)(u^*) = \{z^* \mid u^* - z^* \in \mathbb{R}_+c_1(z), \langle z^*, c_1(z) \rangle \geq 0\}.$$

(iii) if  $\det(z) = 0$  but  $\lambda_1(z) \neq 0$ , i.e.,  $z \in \text{bd } (-\mathcal{K}^n) \setminus \{0\}$ , then

$$\widehat{D}^*S(z)(u^*) = \{z^* \mid z^* \in \mathbb{R}_+c_2(z), \langle u^* - z^*, c_2(z) \rangle \geq 0\}.$$

(iv) if  $\det(z) = 0$  and  $\lambda_1(z) = \lambda_2(z) = 0$ , i.e.,  $z = 0$ , then

$$\widehat{D}^*S(0)(u^*) = \{z^* \mid z^* \in \mathcal{K}^n, u^* - z^* \in \mathcal{K}^n\}.$$

*Proof*

(i) It follows trivially since, if  $\det(z) \neq 0$ , then  $S(\cdot)$  is continuously differentiable around  $z$  and  $S'(z)$  is self-adjoint.

(ii) From (2.6) and Lemma 2 (ii), we know that

$$\begin{aligned} z^* \in \widehat{D}^*S(z)(u^*) &\iff \langle z^* - u^*, h \rangle + 2\langle u^*, ((c_1(z))^T h)_{-c_1(z)} \rangle \leq 0 \quad \forall h \in \mathbb{R}^n \\ &\iff \begin{cases} \langle z^* - u^*, h \rangle \leq 0 & \forall (c_1(z))^T h \geq 0, \\ \langle z^* - u^*, h \rangle + 2\langle u^*, c_1(z) \rangle (c_1(z))^T h \leq 0 & \forall (c_1(z))^T h \leq 0, \end{cases} \end{aligned}$$

which implies

$$z^* \in \widehat{D}^*S(z)(u^*) \iff \exists \alpha \geq 0 \text{ such that } u^* - z^* = \alpha c_1(z) \ \& \ -\alpha + \langle u^*, c_1(z) \rangle \geq 0,$$

i.e.,

$$z^* \in \widehat{D}^*S(z)(u^*) \iff \exists \alpha \geq 0 \text{ such that } u^* - z^* = \alpha c_1(z) \ \& \ \langle z^*, c_1(z) \rangle \geq 0,$$

because

$$\langle z^*, c_1(z) \rangle = \langle u^*, c_1(z) \rangle - 2\alpha(c_1(z))^T c_1(z) \geq \alpha - \alpha = 0.$$

This shows part (ii).

(iii) This can be done similarly to (ii). We omit the details here for brevity.

(iv) Let  $z^* \in \widehat{D}^*S(0)(u^*)$ . Then, from (2.6) and Lemma 2 (iv), we know that

$$\langle z^*, h \rangle \leq \langle u^*, S(h) \rangle \quad \forall h \in \mathbb{R}^n,$$

which, together with the fact that  $S(h) = 0$  for any  $h \in -\mathcal{K}^n$ , implies

$$\begin{cases} \langle z^*, h \rangle \leq \langle u^*, h \rangle & \forall h \in \mathcal{K}^n, \\ \langle z^*, h \rangle \leq 0 & \forall h \in -\mathcal{K}^n. \end{cases}$$

Therefore,  $u^* - z^* \in \mathcal{K}^n$  and  $z^* \in \mathcal{K}^n$ .

Conversely, let  $z^* \in \mathbb{R}^n$  be such that  $u^* - z^* \in \mathcal{K}^n$  and  $z^* \in \mathcal{K}^n$ . Then we have for any  $h \in \mathbb{R}^n$  that

$$\begin{aligned} \langle z^*, h \rangle - \langle u^*, S(h) \rangle &= \langle z^*, S(h) + \text{Proj}_{-\mathcal{K}^n}(h) \rangle - \langle u^*, S(h) \rangle \\ &= \langle z^* - u^*, S(h) \rangle + \langle z^*, \text{Proj}_{-\mathcal{K}^n}(h) \rangle \\ &\leq 0. \end{aligned}$$

Thus,

$$\langle z^*, h \rangle \leq \langle u^*, S(h) \rangle \quad \forall h \in \mathbb{R}^n,$$

which, together with Lemma 2 (iv) and (2.6), shows that  $z^* \in \widehat{D}^*S(0)(u^*)$ . The proof is now completed.  $\square$

Next, we compute the (limiting) coderivative  $D^*S(z)$ . Since  $S(\cdot)$  is continuous, the graph of  $S$  is closed and, by [19, Equation 8(18)], we know that

$$D^*S(z)(u^*) = \text{Lim sup}_{z' \rightarrow z, u \rightarrow u^*} \widehat{D}^*S(z')(u). \tag{2.7}$$

This, together with Lemma 1 and Theorem 1, allows us to provide a complete characterization of  $D^*S(z)$ .

**Theorem 2** *Let  $z \in \mathbb{R}^n$  have the spectral decomposition as in (2.2). Let  $u^* \in \mathbb{R}^n$ . It holds that*

(i) *if  $\det(z) \neq 0$ , then*

$$D^*S(z)(u^*) = \{S'(z)u^*\} = \bar{\partial}_B S(z)u^*.$$

(ii) *if  $\det(z) = 0$  but  $\lambda_2(z) \neq 0$ , i.e.,  $z \in \text{bd } \mathcal{K}^n \setminus \{0\}$ , then*

$$D^*S(z)(u^*) = \bar{\partial}_B S(z)u^* \cup \{z^* \mid u^* - z^* \in \mathbb{R}_+c_1(z), \langle z^*, c_1(z) \rangle \geq 0\}. \tag{2.8}$$

(iii) *if  $\det(z) = 0$  but  $\lambda_1(z) \neq 0$ , i.e.,  $z \in \text{bd } (-\mathcal{K}^n) \setminus \{0\}$ , then*

$$D^*S(z)(u^*) = \bar{\partial}_B S(z)u^* \cup \{z^* \mid z^* \in \mathbb{R}_+c_2(z), \langle u^* - z^*, c_2(z) \rangle \geq 0\}. \tag{2.9}$$

(iv) *if  $\det(z) = 0$  and  $\lambda_1(z) = \lambda_2(z) = 0$ , i.e.,  $z = 0$ , then*

$$\begin{aligned} D^*S(0)(u^*) &= \bar{\partial}_B S(0)u^* \cup \{z^* \mid z^* \in \mathcal{K}^n, u^* - z^* \in \mathcal{K}^n\} \\ &\cup \bigcup_{\xi \in C} \{z^* \mid u^* - z^* \in \mathbb{R}_+\xi, \langle z^*, \xi \rangle \geq 0\} \\ &\cup \bigcup_{\eta \in C} \{z^* \mid z^* \in \mathbb{R}_+\eta, \langle u^* - z^*, \eta \rangle \geq 0\}, \end{aligned} \tag{2.10}$$

where

$$C := \left\{ 1/2(w, 1)^T \mid w \in \mathbb{R}^{n-1}, \|w\|_2 = 1 \right\}.$$

*Proof* Parts (i)–(iii) follow easily from (2.7), Lemma 1, and Theorem 1. We only need to show part (iv).

By (2.7) and Theorem 1, we have

$$\begin{aligned}
 D^*S(0)(u^*) &= \text{Lim sup}_{z \rightarrow 0, u \rightarrow u^*} \widehat{D}^*S(z)(u) = \text{Lim sup}_{\substack{z \rightarrow 0, u \rightarrow u^* \\ \det(z) \neq 0}} \widehat{D}^*S(z)(u) \\
 &\cup \text{Lim sup}_{u \rightarrow u^*} \widehat{D}^*S(0)(u) \cup \text{Lim sup}_{\substack{z \rightarrow 0, u \rightarrow u^* \\ \det(z)=0, \lambda_2(z) \neq 0}} \widehat{D}^*S(z)(u) \\
 &\cup \text{Lim sup}_{\substack{z \rightarrow 0, u \rightarrow u^* \\ \det(z)=0, \lambda_1(z) \neq 0}} \widehat{D}^*S(z)(u) \\
 &= \bar{\partial}_B S(0)(u^*) \cup \text{Lim sup}_{u \rightarrow u^*} \{z^* \in \mathcal{K}^n \mid u - z^* \in \mathcal{K}^n\} \\
 &\cup \text{Lim sup}_{z \rightarrow 0, u \rightarrow u^*} \{z^* \mid u - z^* \in \mathbb{R}_+ c_1(z), \langle z^*, c_1(z) \rangle \geq 0\} \\
 &\cup \text{Lim sup}_{z \rightarrow 0, u \rightarrow u^*} \{z^* \mid z^* \in \mathbb{R}_+ c_2(z), \langle u - z^*, c_2(z) \rangle \geq 0\} \\
 &= \bar{\partial}_B S(0)(u^*) \cup \{z^* \in \mathcal{K}^n \mid u^* - z^* \in \mathcal{K}^n\} \\
 &\cup \bigcup_{\xi \in C} \{z^* \mid u^* - z^* \in \mathbb{R}_+ \xi, \langle z^*, \xi \rangle \geq 0\} \\
 &\cup \bigcup_{\eta \in D} \{z^* \mid z^* \in \mathbb{R}_+ \eta, \langle u^* - z^*, \eta \rangle \geq 0\},
 \end{aligned}$$

where  $C := \{1/2(-w, 1)^T \mid w \in \mathbb{R}^{n-1}, \|w\|_2 = 1\}$ ,  $D := \{1/2(w, 1)^T \mid w \in \mathbb{R}^{n-1}, \|w\|_2 = 1\}$ . Since  $C = D$ , the result follows. □

Let  $z \in \mathbb{R}^n$ . Then Theorem 2 says that  $\bar{\partial}_B S(z)u^*$  is a (possibly proper) subset of  $D^*S(z)(u^*)$  for any  $u^* \in \mathbb{R}^n$ . On the other hand, by [15, (2.33)] we know that

$$\bar{\partial} S(z)u^* = (\text{conv } \bar{\partial}_B S(z))u^* = \text{conv } D^*S(z)(u^*) \quad \forall u^* \in \mathbb{R}^n.$$

The transpositions at the first two sets could be omitted due to the symmetry of all matrices in  $\bar{\partial}_B S(z)$ . So, for a fixed argument  $u^*$ , both sets  $\bar{\partial}_B S(z)(u^*)$  and  $D^*S(z)(u^*)$  generate the set  $\bar{\partial} S(z)(u^*)$  via taking the convex hull.

Next we reformulate the formulas in statements (ii)–(iv) of Theorem 2 in terms of simple projection operators. To this purpose we observe that for any  $z \in \mathbb{R}^n$  with  $z^t \neq 0$  one has

$$A(z) := I + 1/2 \begin{bmatrix} -\frac{z^t(z^t)^T}{\|z^t\|_2^2} & \frac{z^t}{\|z^t\|_2} \\ \frac{(z^t)^T}{\|z^t\|_2} & -1 \end{bmatrix} = \text{Proj}_{(c_1(z))^\perp}(\cdot), \tag{2.11}$$

and

$$B(z) := 1/2 \begin{bmatrix} \frac{z^t(z^t)^T}{\|z^t\|_2^2} & \frac{z^t}{\|z^t\|_2} \\ \frac{(z^t)^T}{\|z^t\|_2} & 1 \end{bmatrix} = I - \text{Proj}_{(c_2(z))^\perp}(\cdot). \tag{2.12}$$



**Theorem 3** *Let  $z \in \mathbb{R}^n$  have the spectral decomposition as in (2.2) and let  $u^* \in \mathbb{R}^n$ . Then one has*

(i) *if  $\det(z) = 0$  but  $\lambda_2(z) \neq 0$ , i.e.,  $z \in \text{bd } \mathcal{K}^n \setminus \{0\}$ , then*

$$D^*S(z)(u^*) = \begin{cases} \text{conv} \{u^*, A(z)u^*\} & \text{if } \langle u^*, c_1(z) \rangle \geq 0 \\ \{u^*, A(z)u^*\} & \text{otherwise.} \end{cases} \tag{2.13}$$

(ii) *if  $\det(z) = 0$  but  $\lambda_1(z) \neq 0$ , i.e.,  $z \in \text{bd}(-\mathcal{K}^n) \setminus \{0\}$ , then*

$$D^*S(z)(u^*) = \begin{cases} \text{conv}\{0, B(z)u^*\} & \text{if } \langle u^*, c_2(z) \rangle \geq 0 \\ \{0, B(z)u^*\} & \text{otherwise.} \end{cases} \tag{2.14}$$

*Proof* To prove (i) we observe that the second set on the right-hand side of (2.8) amounts to the line segment  $[u^*, \text{Proj}_{(c_1(z))^\perp}(u^*)]$  provided  $\langle u^*, c_1(z) \rangle \geq 0$  and to the empty set otherwise. So, it suffices to invoke (2.11) and apply it to both terms on the right-hand side of (2.8), taking into account Lemma 1 (ii).

Analogously, concerning the statement (ii), the second term on the right-hand side of (2.9) amounts to the line segment  $[0, u^* - \text{Proj}_{(c_2(z))^\perp}(u^*)]$  provided  $\langle u^*, c_2(z) \rangle \geq 0$  and to the empty set otherwise. By virtue of (2.12) and Lemma 1 (iii) this leads to the expression (2.14). □

In the case of formula (2.10) we exploit the above result and arrive at the following statement (where the set  $D$  has been introduced in the proof of Theorem 2).

**Theorem 4** *Let  $\bar{z} = 0$  and  $u^* \in \mathbb{R}^n$ . Then*

$$\begin{aligned} D^*S(\bar{z})(u^*) &= \bar{\partial}_B S(0)u^* \cup (\mathcal{K}^n \cap u^* - \mathcal{K}^n) \\ &\cup \bigcup_{\substack{\xi \in C, \\ \langle u^*, \xi \rangle \geq 0}} [u^*, \text{Proj}_{\xi^\perp}(u^*)] \cup \bigcup_{\substack{\eta \in D, \\ \langle u^*, \eta \rangle \geq 0}} [0, u^* - \text{Proj}_{\eta^\perp}(u^*)] \\ &= \bar{\partial}_B S(0)u^* \cup (\mathcal{K}^n \cap u^* - \mathcal{K}^n) \cup \bigcup_{A \in \mathcal{A}} \text{conv} \{u^*, Au^*\} \\ &\cup \bigcup_{B \in \mathcal{B}} \text{conv}\{0, Bu^*\}, \end{aligned} \tag{2.15}$$

where

$$\mathcal{A} := \left\{ I + 1/2 \begin{bmatrix} -ww^T & w \\ w^T & -1 \end{bmatrix} \mid w \in \mathbb{R}^{n-1}, \|w\|_2 = 1, \left\langle u^*, \begin{bmatrix} -w \\ 1 \end{bmatrix} \right\rangle \geq 0 \right\}$$

$$\mathcal{B} := \left\{ 1/2 \begin{bmatrix} ww^T & w \\ w^T & 1 \end{bmatrix} \mid w \in \mathbb{R}^{n-1}, \|w\|_2 = 1, \left\langle u^*, \begin{bmatrix} w \\ 1 \end{bmatrix} \right\rangle \geq 0 \right\}.$$

*Proof* The first equality follows from Theorem 2 and the argument used in the proof of Theorem 3, applied to all possible limits of sequences  $c_1(z), c_2(z)$  when  $z \rightarrow 0$ . The

second equality is based on the facts that for  $\xi = 1/2(-w, 1)^T$  with some unit vector  $w \in \mathbb{R}^{n-1}$  one has

$$\text{Proj}_{\xi^\perp}(\cdot) = I + 1/2 \begin{bmatrix} -ww^T & w \\ w^T & -1 \end{bmatrix}$$

and for  $\eta = 1/2(\tilde{w}, 1)^T$  with some unit vector  $\tilde{w} \in \mathbb{R}^{n-1}$  one has

$$(\cdot) - \text{Proj}_{\eta^\perp}(\cdot) = 1/2 \begin{bmatrix} \tilde{w}\tilde{w}^T & \tilde{w} \\ \tilde{w}^T & 1 \end{bmatrix}.$$

□

Theorem 4 provides us with a deep insight into the structure of the coderivative multifunction and enables us to compute its values (images) in an efficient way. This is shown by means of a simple academic example.

*Example 1* Let  $n = 2$  (so that  $\mathcal{K}^n$  is a polyhedral cone) and  $u^* = \begin{bmatrix} 1 \\ 0 \end{bmatrix}$ . Then one has by virtue of (iv) in Lemma 1 that

$$\bar{\partial}_B S(0) = \left\{ I, \begin{bmatrix} 0 & 0 \\ 0 & 0 \end{bmatrix}, \begin{bmatrix} 1/2 & 1/2 \\ 1/2 & 1/2 \end{bmatrix}, \begin{bmatrix} 1/2 & -1/2 \\ -1/2 & 1/2 \end{bmatrix} \right\},$$

where the third and the fourth matrix is generated by the choice  $w = 1$  and  $w = -1$  in (2.5), respectively. Consequently,

$$\bar{\partial}_B S(0)u^* = \left\{ \begin{bmatrix} 1 \\ 0 \end{bmatrix}, \begin{bmatrix} 0 \\ 0 \end{bmatrix}, \begin{bmatrix} 1/2 \\ 1/2 \end{bmatrix}, \begin{bmatrix} 1/2 \\ -1/2 \end{bmatrix} \right\}.$$

By Theorem 4, we have

$$\begin{aligned} DS^*(0)(u^*) &= \underbrace{\left\{ \begin{bmatrix} 1 \\ 0 \end{bmatrix}, \begin{bmatrix} 0 \\ 0 \end{bmatrix}, \begin{bmatrix} 1/2 \\ 1/2 \end{bmatrix}, \begin{bmatrix} 1/2 \\ -1/2 \end{bmatrix} \right\}}_{\text{1st term}} \cup \underbrace{\emptyset}_{\text{2nd term}} \\ &\cup \underbrace{\text{conv} \left\{ \begin{bmatrix} 1 \\ 0 \end{bmatrix}, \begin{bmatrix} 1/2 \\ -1/2 \end{bmatrix} \right\}}_{\text{3rd term}} \cup \underbrace{\text{conv} \left\{ \begin{bmatrix} 0 \\ 0 \end{bmatrix}, \begin{bmatrix} 1/2 \\ 1/2 \end{bmatrix} \right\}}_{\text{4th term}} \\ &= \text{conv} \left\{ \begin{bmatrix} 1 \\ 0 \end{bmatrix}, \begin{bmatrix} 1/2 \\ -1/2 \end{bmatrix} \right\} \cup \text{conv} \left\{ \begin{bmatrix} 0 \\ 0 \end{bmatrix}, \begin{bmatrix} 1/2 \\ 1/2 \end{bmatrix} \right\}. \end{aligned}$$

The sets  $D^*S(0)(u^*)$  and  $\bar{\partial}S(0)u^*$  are depicted on Figs. 1, 2, respectively.

**Fig. 1**  $D^*S(0)(u^*)$

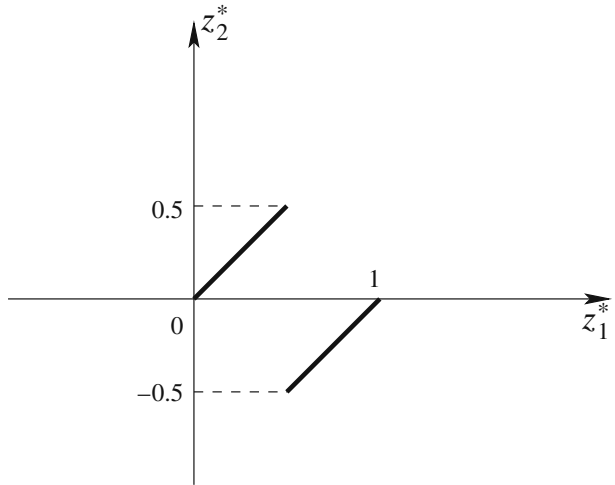

The situation changes if we replace  $u^*$  by  $\tilde{u}^* = \begin{bmatrix} 0 \\ 1 \end{bmatrix}$ . In this case

$$\bar{\partial}_B S(0)\tilde{u}^* = \left\{ \begin{bmatrix} 1/2 \\ 1/2 \end{bmatrix}, \begin{bmatrix} -1/2 \\ 1/2 \end{bmatrix}, \begin{bmatrix} 0 \\ 0 \end{bmatrix}, \begin{bmatrix} 0 \\ 1 \end{bmatrix} \right\}.$$

Concerning the coderivative  $D^*S(0)(\tilde{u}^*)$ , the second term in (2.10) is now nonempty and amounts to the convex hull of  $\bar{\partial}_B S(0)\tilde{u}^*$ . Consequently,

$$D^*S(0)(\tilde{u}^*) = \bar{\partial} S(0)\tilde{u}^*.$$

**Fig. 2**  $\bar{\partial} S(0)u^*$

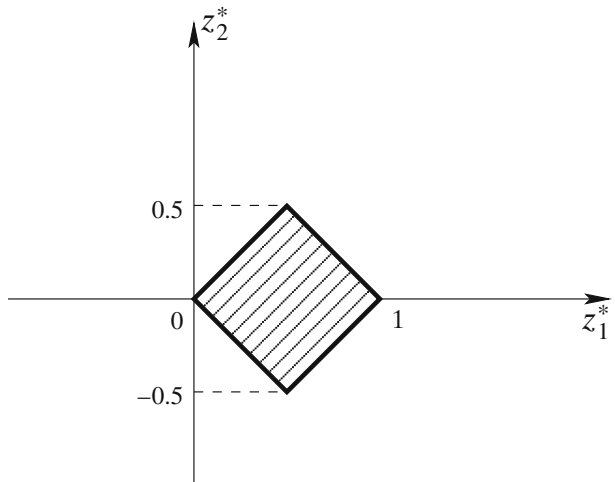

### 3 Stability of Complementarity Constraints

The results of the preceding section can be used, among others, in stability analysis of a parameter-dependent second-order cone complementarity problem (CP)

$$y \in \mathcal{K}^n, F(x, y) \in \mathcal{K}^n, (y, F(x, y)) = 0, \tag{3.1}$$

where  $F: \mathbb{R}^m \times \mathbb{R}^n \rightarrow \mathbb{R}^n$  is a continuously differentiable mapping and  $(\cdot, \cdot)$  denotes the standard Euclidean inner product. Of course, if  $F(x, y) = f'_y(x, y)$  for a function  $f: \mathbb{R}^m \times \mathbb{R}^n \rightarrow \mathbb{R}$ , convex in  $y$ , then (3.1) amounts to a necessary and sufficient optimality condition for the parameterized optimization problem

$$\begin{aligned} &\text{minimize } f(x, y) \\ &\text{subject to } \\ &\quad y \in \mathcal{K}^n. \end{aligned} \tag{3.2}$$

Our aim is to analyze the Aubin property of the *solution map*  $L: \mathbb{R}^m \rightrightarrows \mathbb{R}^n$  defined by

$$L(x) := \{y \in \mathcal{K}^n \mid \mathcal{F}(x, y) \in \mathcal{K}^n, (y, F(x, y)) = 0\} \tag{3.3}$$

around a *reference point*  $(\bar{x}, \bar{y}) \in \text{Graph } L$ . We recall from [1] that  $L$  possesses the Aubin property around  $(\bar{x}, \bar{y})$  provided there are neighborhoods  $\mathcal{U}$  and  $\mathcal{V}$  of  $\bar{x}$  and  $\bar{y}$ , respectively, and a modulus  $l \geq 0$  such that

$$L(x_1) \cap \mathcal{V} \subset L(x_2) + l\|x_1 - x_2\|_2 \mathbb{B} \text{ for all } x_1, x_2 \in \mathcal{U}.$$

Of course,  $\|\cdot\|_2$  can be replaced by a different norm. It has been proved in [13] and [14] that the Aubin property of  $L$  around  $(\bar{x}, \bar{y})$  is equivalent to the coderivative condition

$$D^*L(\bar{x}, \bar{y})(0) = \{0\}, \tag{3.4}$$

see also [16, Theorem 4.10]. This condition is frequently called the Mordukhovich criterion ([19, Theorem 9.40]).

**Theorem 5** *Assume that the qualification condition*

$$\left. \begin{aligned} &-(F'_x(\bar{x}, \bar{y}))^T v^* = 0 \\ &u^* = v^* - (F'_y(\bar{x}, \bar{y}))^T v^* \\ &v^* \in D^*S(\bar{y} - F(\bar{x}, \bar{y}))(u^*) \end{aligned} \right\} \Rightarrow u^* = 0 \tag{3.5}$$

*holds true (recall that  $S(\cdot) = \text{Proj}_{\mathcal{K}^n}(\cdot)$ ). Then for all  $y^* \in \mathbb{R}^n$  one has*

$$\begin{aligned} D^*L(\bar{x}, \bar{y})(y^*) &\subset \{-(F'_x(\bar{x}, \bar{y}))^T v^* \mid u^* = y^* + v^* - (F'_y(\bar{x}, \bar{y}))^T v^* \\ &\quad v^* \in D^*S(\bar{y} - F(\bar{x}, \bar{y}))(u^*)\}. \end{aligned} \tag{3.6}$$

*Proof* It suffices to observe that

$$\begin{aligned} \text{Graph } L &= \{(x, y) \in \mathbb{R}^m \times \mathbb{R}^n \mid y = S(y - F(x, y))\} \\ &= \left\{ (x, y) \in \mathbb{R}^m \times \mathbb{R}^n \mid \begin{bmatrix} y - F(x, y) \\ y \end{bmatrix} \in \text{Graph } S \right\}, \end{aligned}$$

and apply [15, Theorem 6.10]. In (3.5) the condition  $u^* = 0$  ensures automatically that  $v^* = 0$  as well. Indeed, this follows from the Lipschitz continuity of the projection by virtue of condition (3.4).  $\square$

It is easy to see that the qualification condition (3.5) is fulfilled whenever the parametrization of (3.1) is ample, i.e.,  $F'_x(\bar{x}, \bar{y})$  is surjective. Then, in addition, the inclusion in (3.6) becomes equality, because the Jacobian of

$$\begin{bmatrix} y - F(x, y) \\ y \end{bmatrix}$$

has its full row rank ([19, Exercise 10.7], [16, Proposition 1.112]).

The inclusion (3.6) can be used for testing of the Aubin property of  $L$  via the mentioned Mordukhovich criterion. This is illustrated in the next example.

*Example 2* Consider the parameterized program

$$\begin{aligned} &\text{minimize} && 1/2(y_3)^2 + (x, y) \\ &\text{subject to} && y \in \mathcal{K}^3 \end{aligned}$$

around the reference point  $(\bar{x}, \bar{y}) = (0, 0)$ . In the equivalent CP (3.1) one has

$$F(x, y) = \begin{bmatrix} x_1 \\ x_2 \\ y_3 + x_3 \end{bmatrix}. \tag{3.7}$$

Since  $F'_x(\bar{x}, \bar{y}) = I$  is surjective, inclusion (3.6) becomes equality. We claim that

$$D^*L(0, 0)(0) = -\{v^* \in \mathbb{R}^3 \mid v_1^* = u_1^*, v_2^* = u_2^*, u_3^* = 0, v^* \in D^*S(0)(u^*)\}$$

contains a nonzero vector. To prove it, consider the third term on the right-hand side of (2.15) with  $w = (1/\sqrt{2}, 1/\sqrt{2})^T$  and  $u^* = (1, -1, 0)^T$ . Clearly,

$$\left\langle u^*, \begin{bmatrix} -w \\ 1 \end{bmatrix} \right\rangle = 0$$

and so the matrix

$$A = I + 1/2 \begin{bmatrix} -ww^T & w \\ w^T & -1 \end{bmatrix} = I + \begin{bmatrix} -1/4 & -1/4 & 1/2\sqrt{2} \\ -1/4 & -1/4 & 1/2\sqrt{2} \\ 1/2\sqrt{2} & 1/2\sqrt{2} & -1/2 \end{bmatrix} = \begin{bmatrix} 3/4 & -1/4 & 1/2\sqrt{2} \\ -1/4 & 3/4 & 1/2\sqrt{2} \\ 1/2\sqrt{2} & 1/2\sqrt{2} & 1/2 \end{bmatrix}$$

belongs to the set  $\mathcal{A}$  (cf. Theorem 4). One has

$$Au^* = (1, -1, 0)^T$$

so that  $v^* = (1, -1, 0)^T \in D^*L(0, 0)(0)$ . It follows that the Mordukhovich criterion  $D^*L(0, 0)(0) = \{0\}$  is violated and so  $L$  does not possess the Aubin property around  $(0, 0)$ .

Next we derive necessary optimality conditions for the *mathematical program with equilibrium constraints* (MPEC)

$$\begin{aligned}
 & \text{minimize } f(x, y) \\
 & \text{subject to} \\
 & \quad y \in L(x) \\
 & \quad (x, y) \in \kappa,
 \end{aligned} \tag{3.8}$$

where the objective  $f: \mathbb{R}^m \times \mathbb{R}^n \rightarrow \mathbb{R}$  is locally Lipschitz and  $\kappa$  is a closed set in  $\mathbb{R}^m \times \mathbb{R}^n$ .

**Theorem 6** *Let  $(\bar{x}, \bar{y})$  be a (local) solution of (3.8). Assume that the qualification condition*

$$\left. \begin{aligned}
 & \left[ \begin{array}{l} -(F'_x(\bar{x}, \bar{y}))^T v^* \\ v^* - (F'_y(\bar{x}, \bar{y}))^T v^* + u^* \end{array} \right] \in -N_\kappa(\bar{x}, \bar{y}) \\
 & (v^*, u^*) \in N_{\text{Graph } S}(\bar{x}, \bar{y})
 \end{aligned} \right\} \Rightarrow v^* = 0, u^* = 0 \tag{3.9}$$

*is fulfilled. Then there exist a pair of multipliers  $(v^*, u^*) \in N_{\text{Graph } S}(\bar{y} - F(\bar{x}, \bar{y}), \bar{y})$  such that*

$$0 \in \partial f(\bar{x}, \bar{y}) + \left[ \begin{array}{l} -(F'_x(\bar{x}, \bar{y}))^T v^* \\ v^* - (F'_y(\bar{x}, \bar{y}))^T v^* + u^* \end{array} \right] + N_\kappa(\bar{x}, \bar{y}). \tag{3.10}$$

*Proof* The constraint system in (3.8) can be written down in the form

$$\Omega := \{z \in \kappa \mid \Phi(z) \in \text{Graph } S\},$$

where  $z = (x, y)$  and

$$\Phi(x, y) := \begin{bmatrix} y - F(x, y) \\ y \end{bmatrix}.$$

By [19, Theorem 6.14] one has (with  $\bar{z} = (\bar{x}, \bar{y})$ ) that

$$N_\Omega(\bar{z}) \subset (\Phi'(\bar{z}))^T N_{\text{Graph } S}(\Phi(\bar{z})) + N_\kappa(\bar{z}), \tag{3.11}$$

whenever the qualification condition

$$\left. \begin{aligned}
 & (\Phi'(\bar{z}))^T \xi \in -N_\kappa(\bar{z}) \\
 & \xi \in N_{\text{Graph } S}(\Phi(\bar{z}))
 \end{aligned} \right\} \Rightarrow \xi = 0 \tag{3.12}$$

is fulfilled. Coming back to the original variables  $x, y$ , it turns out that (3.12) amounts exactly to the qualification condition (3.9). The relationship (3.10) follows directly from (3.11) and the optimality condition

$$0 \in \partial f(\bar{z}) + N_\Omega(\bar{z}),$$

cf. [14, Theorem 7.1]. □

*Example 3* Consider an MPEC (3.8) with

$$f(x, y) = \langle x^*, x \rangle + \langle y^*, y \rangle, \quad x^* = (0, 0, 1/3)^T, \quad y^* = (-1/3, 0, 1)^T,$$

$\kappa = \mathbb{R}^3 \times \mathbb{R}^3$  and  $L$  defined in Example 2. Using a nonlinear programming code from the NEOS server, it is easy to compute that  $(\bar{x}, \bar{y}) = (0, 0)$  is a solution of this MPEC. The qualification condition (3.9) is clearly fulfilled. The relationship (3.10) attains the form (with  $\tilde{u}^* := -u^*$ )

$$\begin{aligned} 0 &= x^* - v^* \\ 0 &= y^* + \begin{bmatrix} v_1^* \\ v_2^* \\ 0 \end{bmatrix} - \tilde{u}^*, \end{aligned}$$

where  $v^* \in D^*S(0)(\tilde{u}^*)$ . Hence,  $v^* = (0, 0, 1/3)^T$  and  $\tilde{u}^* = (-1/3, 0, 1)^T$ . Since  $v^* \in \mathcal{K}^3 \cap (\tilde{u}^* - \mathcal{K}^3)$ , we conclude that the optimality conditions of Theorem 6 are fulfilled by virtue of Theorem 4.

By Theorem 1 (iv), one has in this example even the stronger relationship

$$v^* \in \widehat{D}^*S(0)(\tilde{u}^*).$$

In compliance with [20], we could thus call the point  $(0, 0)$  *strongly stationary*.

By the same technique one can investigate stability of solutions to parameter-dependent second-order cone constrained program

$$\begin{aligned} &\text{minimize } \varphi(x, y) \\ &\text{subject to} \\ &A(x)y + b \in \mathcal{K}^s, \end{aligned} \tag{3.13}$$

where the functions  $\varphi: \mathbb{R}^m \times \mathbb{R}^n \rightarrow \mathbb{R}$ ,  $A: \mathbb{R}^m \rightarrow \mathbb{R}^s \times \mathbb{R}^n$  are assumed to be continuously differentiable and  $b \in \mathbb{R}^s$ . In this case we assume that at the reference pair  $(\bar{x}, \bar{y})$  the “basic” qualification condition

$$\left. \begin{aligned} (A(\bar{x}))^T u &= 0 \\ u \in N_{\mathcal{K}^s}(A(\bar{x})\bar{y} + b) \end{aligned} \right\} \Rightarrow u = 0$$

is fulfilled. Program (3.13) can then be replaced by the “enhanced” nonsmooth equation system

$$\begin{aligned} 0 &= \varphi'_y(x, y) + (A(x))^T u \\ A(x)y + b &= \text{Proj}_{\mathcal{K}^s}(A(x)y + b + u) \end{aligned} \tag{3.14}$$

in variables  $(x, y, u)$  and the coderivative of the corresponding enhanced solution map

$$L(x) := \{(y, u) \in \mathbb{R}^n \times \mathbb{R}^s \mid (y, u) \text{ solves the system (3.14)}\}$$

can be computed on the basis of Theorem 4.

### 4 Conclusion

The B-differentiability of  $S$  has been used to obtain a suitable description of the regular coderivative of  $S$ . A limit procedure leads then directly to the desired limiting coderivative. This technique can be applied also to another single-valued B-differentiable maps. On the basis of this limiting coderivative, we have proposed a

way for testing the Aubin property of solution maps to various parameter-dependent variational inequalities involving  $\mathcal{K}^n$ . In a similar way we have derived optimality conditions for an MPEC with such type of equilibria.

**Acknowledgement** The authors are indebted to an anonymous reviewer for careful reading and an important suggestion.

## References

1. Aubin, J.-P.: Lipschitz behaviour of solutions to convex minimization problems. *Math. Oper. Res.* **9**, 87–111 (1984)
2. Chen, J.-S., Chen, X., Tseng, P.: Analysis of nonsmooth vector-valued functions associated with second-order cones. *Math. Programming* **101**, 95–117 (2004)
3. Chen, X.-D., Sun, D., Sun, J.: Complementarity functions and numerical experiments for second-order cone complementarity problems. *Comput. Optim. Appl.* **25**, 39–56 (2003)
4. Clarke, F.H.: *Optimization and Nonsmooth Analysis*. Wiley, New York (1983)
5. Fariut, U., Korányi, A.: *Analysis on Symmetric Cones*. Oxford Mathematical Monographs. Oxford University Press, New York (1994)
6. Fukushima, M., Luo, Z.-Q., Tseng, P.: Smoothing functions for second-order cone complementarity problems. *SIAM J. Optim.* **12**, 436–460 (2002)
7. Kanzow, C., Ferenzi, I., Fukushima, M.: Semismooth methods for linear and nonlinear second-order cone programs. Technical Report 2006-005, Department of Applied Mathematics and Physics, Kyoto University (April 2006, revised January 2007).
8. Haslinger, J., Sassi, T.: Mixed finite element approximation of 3D contact problems with given friction: error analysis and numerical realization. *Math. Model. Numer. Anal.* **38**, 563–578 (2004)
9. Koecher, M.: In: Brieg, A., Walcher, S. (eds.) *The Minnesota Notes on Jordan Algebras and Their Applications*. Springer, Berlin (1999)
10. Korányi, A.: Monotone functions on formally real Jordan algebras. *Math. Ann.* **269**, 73–76 (1984)
11. Liu, Y.-J., Zhang, L.-W.: Convergence of the augmented Lagrangian method for nonlinear optimization problems over second-order cones. *J. Optim. Theory Appl.* (2008, in press)
12. Lobo, M.S., Vandenberghe, L., Boyd, S., Lebret, H.: Application of second-order cone programming. *Linear Algebra Appl.* **284**, 193–228 (1998)
13. Mordukhovich, B.S.: Nonsmooth analysis with nonconvex generalized differentials and adjoint mappings. *Dokl. Akad. Nauk SSSR* **28**, 976–979 (1984)
14. Mordukhovich, B.S.: *Approximation Methods in Problems of Optimization and Control* (in Russian). Nauka, Moscow (1988)
15. Mordukhovich, B.S.: Generalized differential calculus for nonsmooth and set-valued mappings. *J. Math. Anal. Appl.* **183**, 250–288 (1994)
16. Mordukhovich, B.S.: *Variational Analysis and Generalized Differentiation*, vol. 1. Springer, New York (2006)
17. Pang, J.S., Sun, D.F., Sun, J.: Semismooth homeomorphisms and strong stability of semidefinite and Lorentz cone complementarity problems. *Math. Oper. Res.* **28**, 39–63 (2003)
18. Robinson, S.M.: Strongly regular generalized equation. *Math. Oper. Res.* **5**, 43–62 (1980)
19. Rockafellar, R.T., Wets, R.J.-B.: *Variational Analysis*. Springer, New York (1998)
20. Scheel, H., Scholtes, S.: Mathematical programs with complementarity constraints: stationarity, optimality and sensitivity. *Math. Oper. Res.* **25**, 1–22 (2000)
21. Shapiro, A.: On concepts of directional differentiability. *J. Optim. Theory Appl.* **66**, 477–487 (1990)