

Cryogenics at COMPASS-U

Jozef Varju, Petr Bartoň and the COMPASS-U team

This document is intended for the companies who shown interest in the Preliminary Market Consultation for COMPASS-U Cryogenic system to initiate discussion have feedback on fabrication viability of the system. It will provide very basic information about the system which is in the Design Phase.

Nothing in this document is legally binding.

Version	Published	Changes
1.0	20. 5. 2020	Initial revision
1.1	1. 7. 2020	Added system interfaces, environmental factors, inventory control

- General COMPASS-U informations
- Main cryogenics requirements
- Cooled parts description and cooling circuits parameters
- Cooling system
 - Topologies
 - Cold source
 - Coldbox design
 - Control system
- Tendering
- Operation/buying phases
- Questions

- The **COMPASS-U** will be a high magnetic field (5 T) medium-sized tokamak with high wall temperature (< 500°C) operation.
- The scientific program is aimed to address topics of plasma exhaust, liquid metals, enhanced confinement modes and edge plasma physics.

Basic parameters:

$$R = 0.894 \text{ m}$$

$$a = 0.27 \text{ m}$$

$$B_t = 5 \text{ T}$$

$$I_p = 2 \text{ MA}$$

$$t_{\text{flat-top}} \sim 2 \text{ s}$$

$$V_{\text{plasma}} \sim 2 \text{ m}^3$$

$$T_{\text{wall}} \leq 500 \text{ }^\circ\text{C}$$

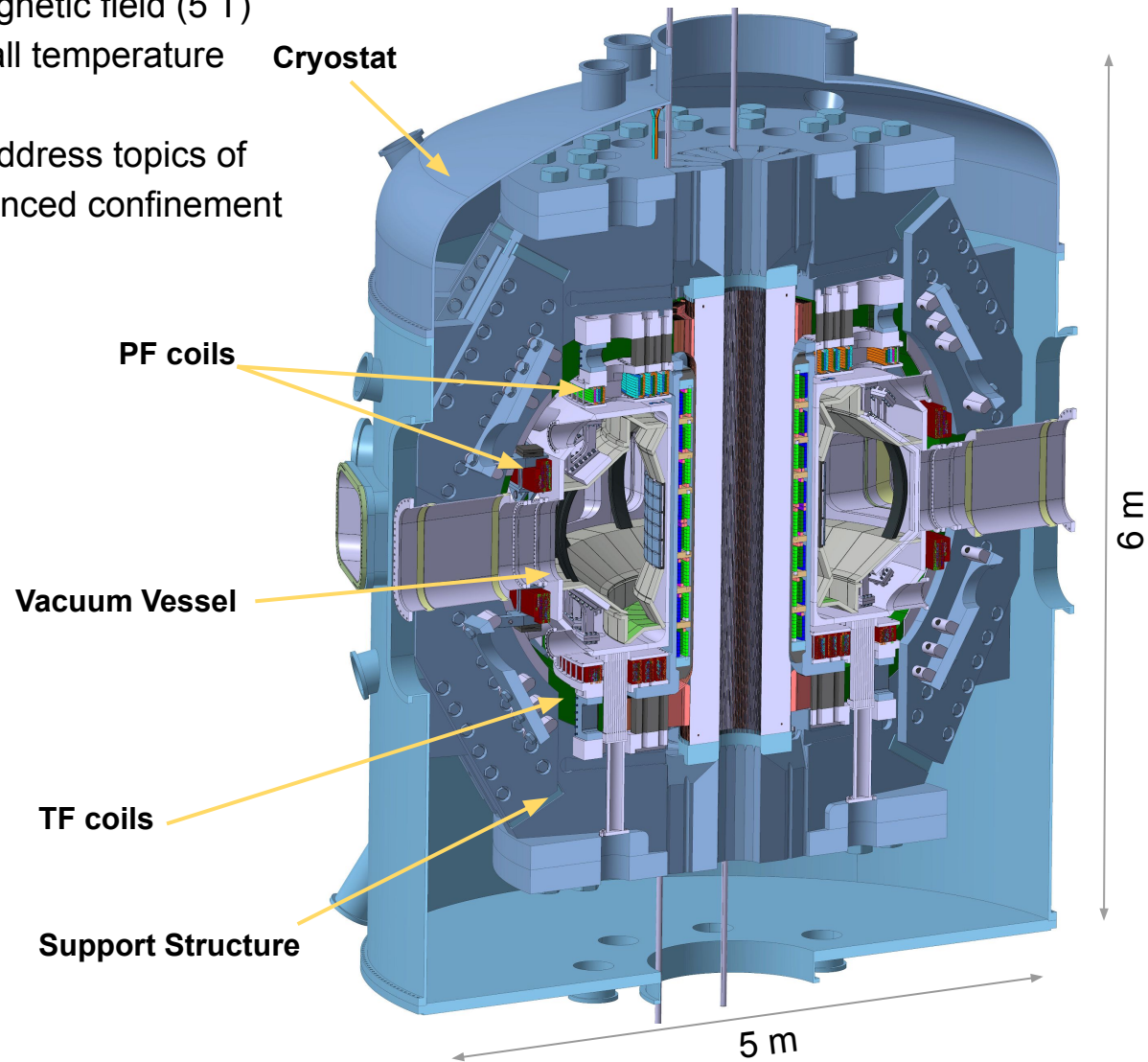

Tokamaks are devices in which various inter-plasma processes (including nuclear fusion) are investigated. Plasma is created and held by strong **magnetic field** in vacuum chamber. By the definition, tokamaks are **pulsed devices** - discharge can be run just for given amount of time, until maximal current through some of magnetic coils is reached.

Implications for COMPASS-U Cryogenics

- To get required parameters (mag. field intensity, discharge length), all device coils will be **made from copper** and **cooled down to ~ 80 K**.
 - This lowers their resistance (5x - 8x), allowing higher current supplied.
- During discharge (~ **5 seconds**) coils will heat up by electric current conduction and afterwards time will be given to cool them down again (~ **30 - 60 minutes**).
 - Coolant circulation will be (probably) turned off/bypassed during discharge itself!
 - **During discharge**, all coils can heat **up to 160 K** (maximal heat up 80 K).

Key facts

- All parts will be cooled by **gaseous coolant loops**.
 - Gaseous loops -> no dangerous phase transitions.
- Working gas **Helium** or **Hydrogen**.
 - Helium preferred because of safety.
- Working gas pressure in range **20 to 60 bar**.
 - Higher pressure is more efficient, however more parts-demanding.
- Target temperature for cooling **~80 K**.
 - Being able to achieve lower temperatures is advantageous, but not required.
- Maximal **difference** between coolant and coil temperature **40 K**.
 - To limit thermal stresses induced in cooled components.
- Number of separate cooling loops is to be determined.
 - Currently **1 to 3 cooling loops** proposed.
 - Each loop consists of several parallel cooling channels.
- Cooling power at 80 K **~200 kW**.
 - Steady state heat losses < 10 kW.

At initial phase all parameters will be limited (as described later).

Tokamak coils can be divided into three “groups”.

- Poloidal field (PF) coils
 - 8 - 10 separate coils made of solid conductor with inner hollow channel.
 - “Average” coil weight ~ 200 kg, conductor length ~ 90 - 500 m, cooling channel lengths ~ 60 - 90 m

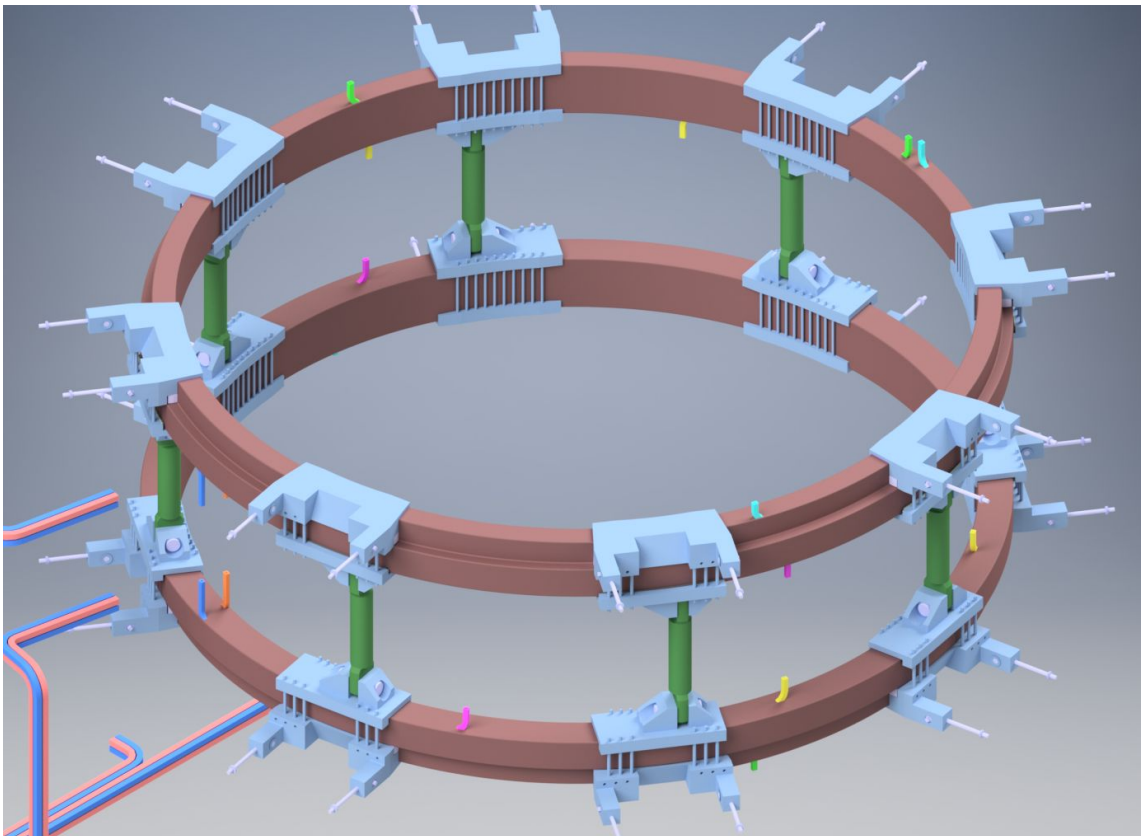

Fig. 2.: PF4U and PF4L coils as example of PF coils. Diameter ~ 3 meters.

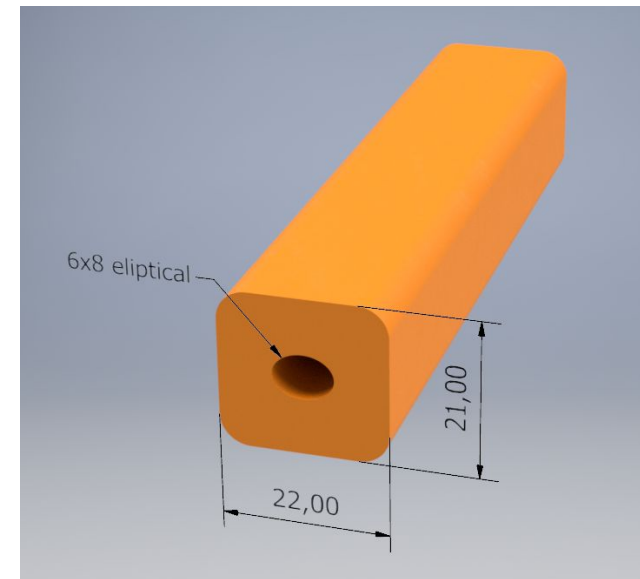

Fig. 3.: Illustration of CS1-4 conductor

Coil	Count	Cooling channels		Coil weight	Maximal energy to extract (<i>per coil</i>)
		Diameter	Lengths		
PF1a	2	7 mm	59 m, 63 m	202 kg	4.5 MJ
PF1b	2	7 mm	69 m, 71 m	231 kg	5.2 MJ
PF2	2	7 mm	77 m, 80 m	261 kg	5.8 MJ
PF3	2	7 mm	81 m, 77 m, 85 m	404 kg	9 MJ
PF4	2	9 mm	77 m, 70 m, 79 m, 73 m, 74 m	921 kg	21 MJ

Each of the coils exists in tokamak twice because of top-down symmetry.

Maximal deposited energy to PF coils during a tokamak discharge (in total, all 10 coils) ~ **20 MJ**

For cooldown within 60 minutes (He cooling loop with base pressure 20 bar), average pressure drop per channel is ~ **1 - 1.5 bar**, average mass flow ~ **4 - 9 g/s**.

- Central solenoid (**CS**) coils
 - Stack of 8 equal coils with equal parameters, same design as for PF coils (hollow copper conductor)
 - Weight ~ 360 kg (each), cooling channel length ~ 95 m

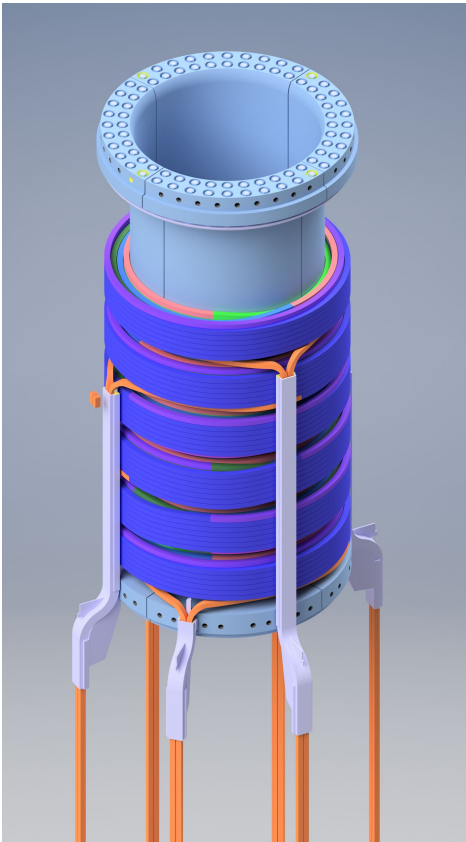

Fig. 4.: Illustration of central solenoid stack, two upper coils hidden

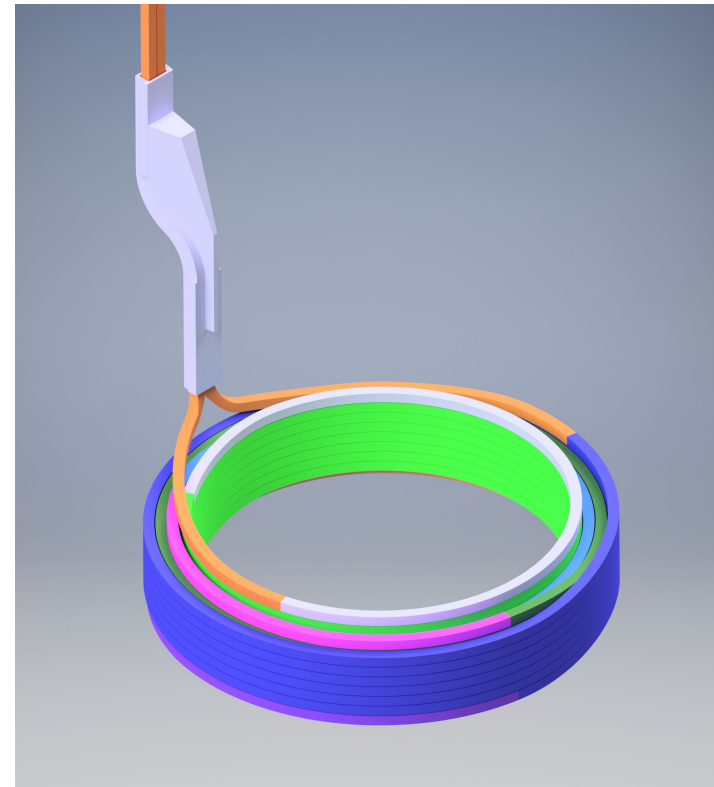

Fig. 5.: Single coil of CS, upside down

Coil	Count	Cooling channels		Coil weight	Maximal energy to extract
		Diameter	Length		
CS1	2	6x8 mm, elliptical	95 m	360 kg	8.1 MJ
CS2	2	6x8 mm, elliptical	94.5 m	358 kg	8.0 MJ
CS3	2	6x8 mm, elliptical	94 m	356 kg	7.9 MJ
CS4	2	6x8 mm, elliptical	93.5 m	354 kg	7.8 MJ

Each of the coils exists in tokamak twice because of top-down symmetry.

Maximal deposited energy to CS coils in one tokamak discharge (in total, all 8 coils) ~ **30 MJ**

For cooldown within 60 minutes (He cooling loop with base pressure 60 bar), average pressure drop per channel is ~ **3.5 bar**, average mass flow ~ **11 g/s** .

- Toroidal field (TF) coil
 - One huge coil (112 turns) made out of copper plates with brazed-on pipe.
 - Weight ~ 25 tons, cooling channel lengths ~ 2 - 5 m

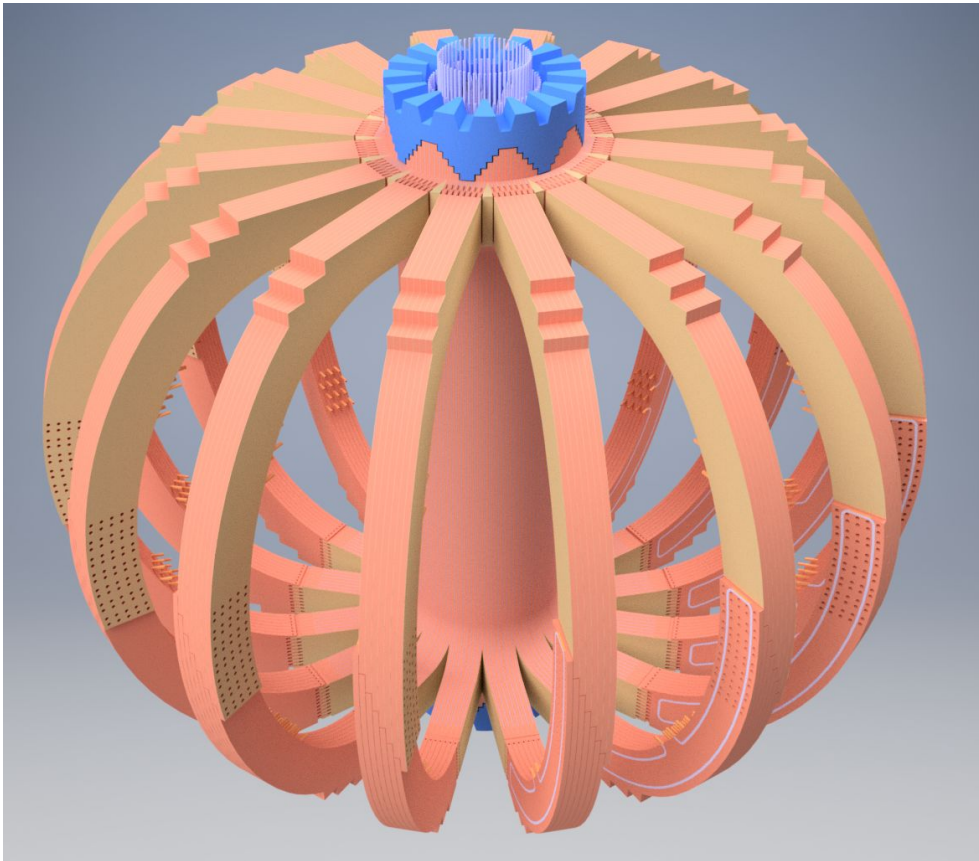

Fig. 6.: Toroidal field coil assembly. Diameter ~ 3.5 meters, height ~ 2.5 meters

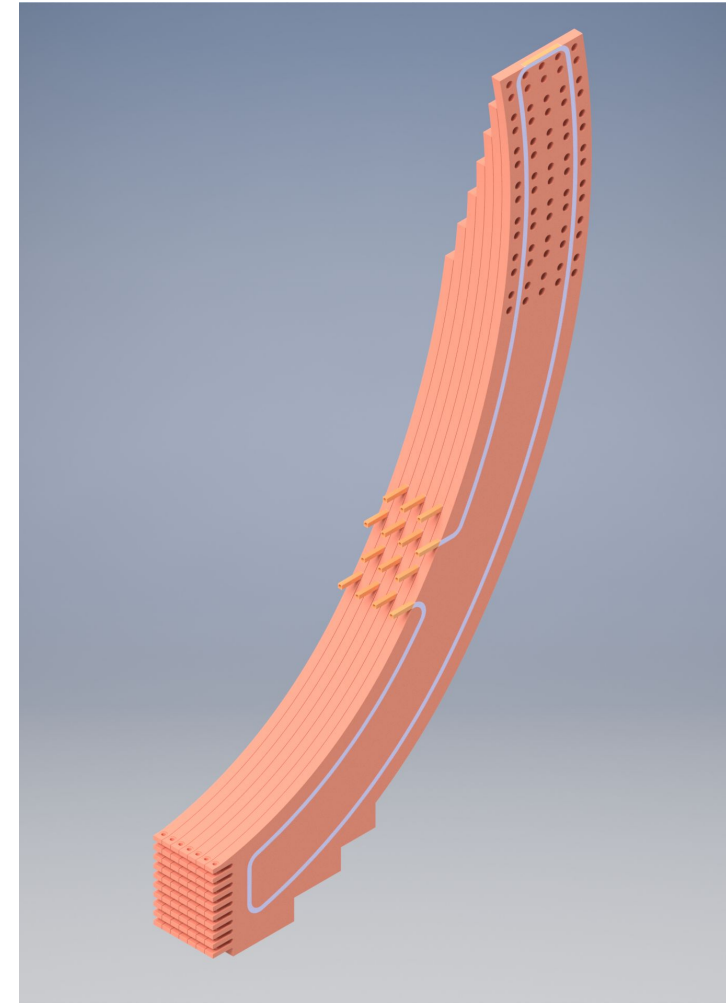

Fig. 7.: Lower outer limb of TF coil, cooling channel visible (in light blue color)

TF coil is one huge coil splitted in many parts, each having its own cooling channel.

Part	Count	Cooling channels		Maximal energy to extract (per channel)
		Diameter	Length	
TF core	112	6 mm	3.2 m	1.21 MJ
TF upper limb	112	6 mm	6.5 m	0.55 MJ
TF lower limb	112	6 mm	5.5 m	0.48 MJ

Maximal deposited energy to TF coil (in total) ~ **250 MJ**

For cooldown within 60 minutes (He cooling loop with base pressure 20 bar), average pressure drop per channel is ~ **0.05 - 0.1 bar**, average mass flow ~ **2 - 4 g/s**.

Currently, we propose having 6 busses (2 for TF core, 2 for TF upper limb, 2 for TF lower limb).

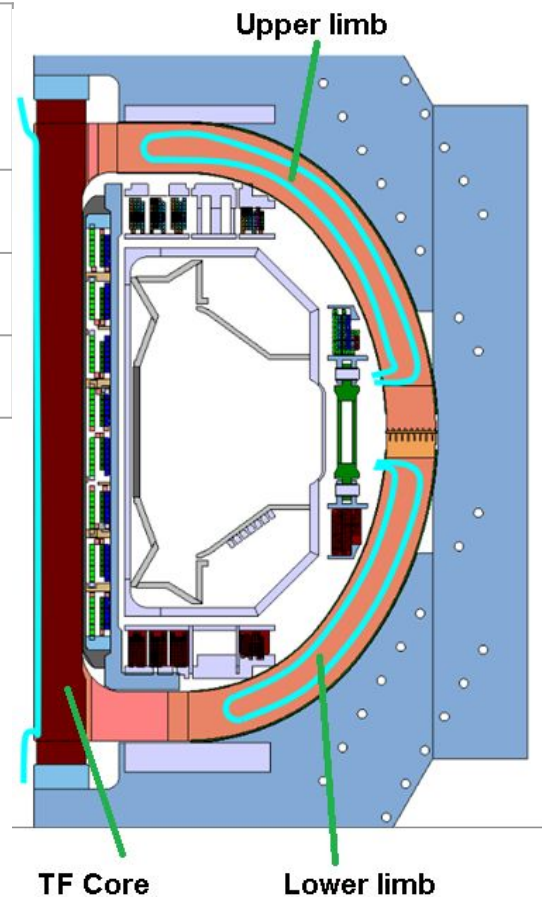

Fig.8.: Illustration of TF coil parts

As said on previous slide, mainly copper coils will be cooled to cryogenic temperatures. However several others parts must be cooled. Those are

- Support structure
 - Huge metallic (SS316) structure holding all coils in place, weight ~ 250 tons
- Coil “busbars”
 - Copper conductors, connecting coils to power sources. Thermal anchor (@160 K) is required not to get them overheated.
- CS Tie tube
 - Metal tube (cut to 4 pieces) holding mechanically preloaded central solenoid stack. Cooling is needed because of thermal expansion.

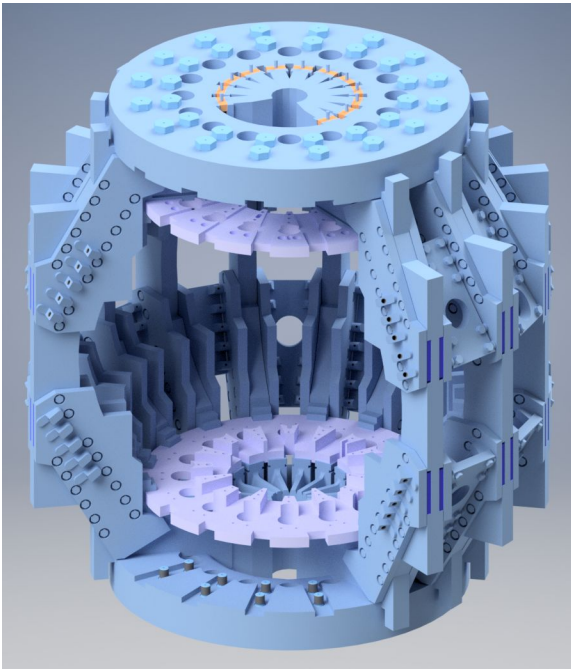

Fig. 9.: Support structure, partial cutout

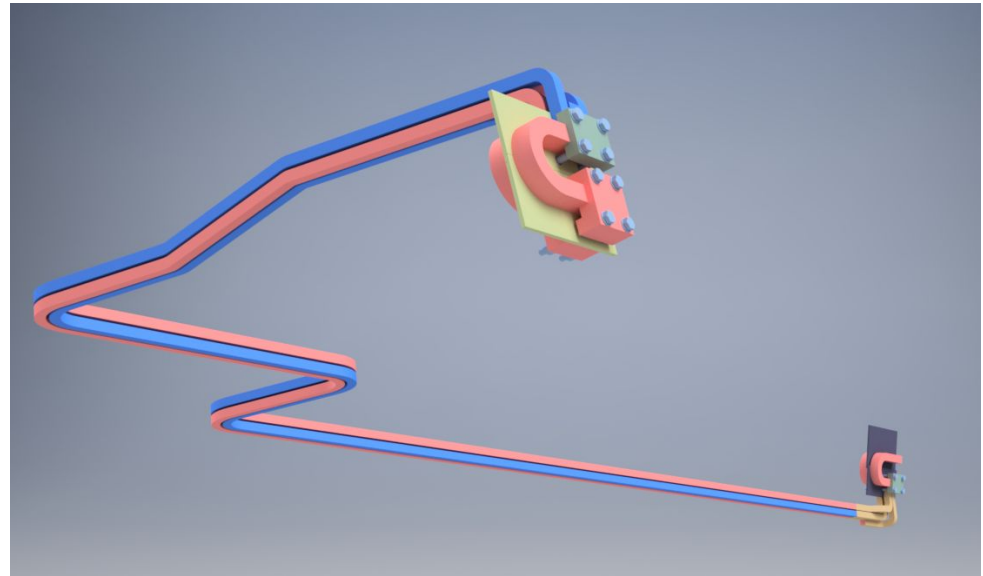

Fig. 10.: Coil busbar leading to PF2U coil.

- There is a lot of different cooling channels with different mass flows/pressure drops, several different topologies are possible.
- Currently proposed topologies
 - **1 loop**
 - Containing all cooled parts
 - *Requires high pressure and high power to cool CS coils which leads to poor efficiency*
 - **2 loops**
 - “High pressure loop” for CS + PF
 - “Low pressure loop” for TF + rest
 - **3 loops**
 - “High pressure loop” for CS
 - “Medium pressure loop” for PF + tietube
 - “Low pressure loop” for TF + rest
 - **2 helium loops + 1 hydrogen loop**
 - “High pressure hydrogen loop” for CS
 - “Medium pressure loop” for PF + tietube
 - “Low pressure loop” for TF + rest
- Less loops
 - + Lower price
 - - Power loss because of throttling valves
- More loops
 - + Better efficiency
 - - Higher price, complicated system

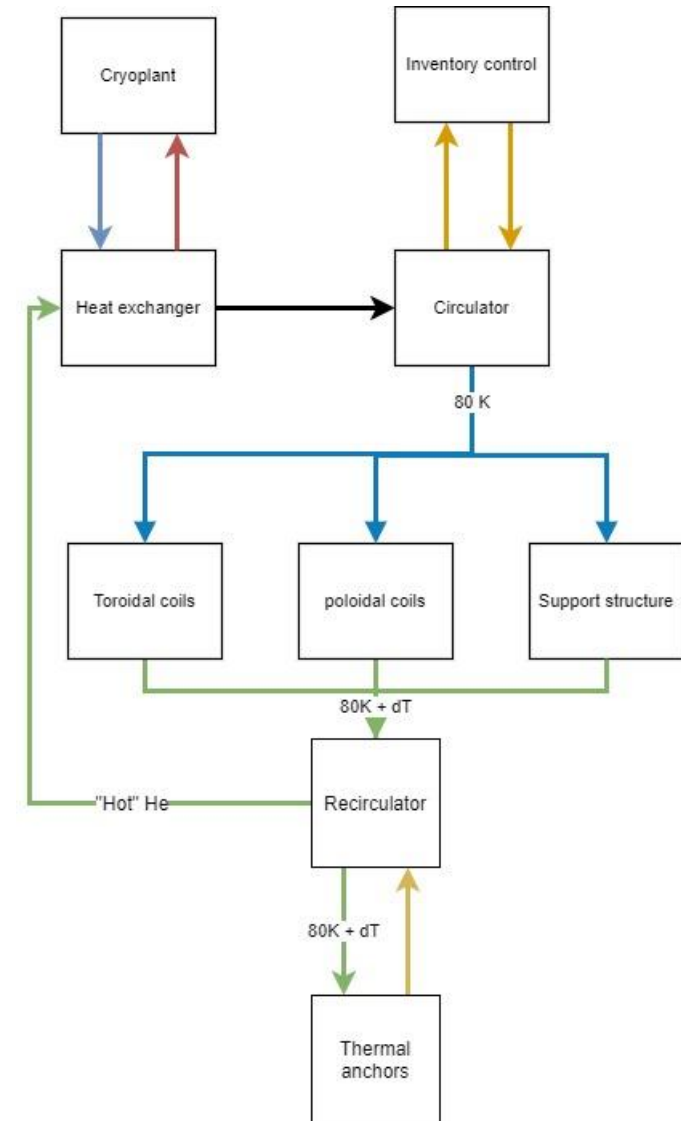

Fig. 11.: Simplified diagram of 1 loop cooling scheme

- **Boundary conditions**

- Requirements
 - Cooling power ~ **20 - 200 kW** (initial and final)
 - Target temperature ~ **80 K**
- Benefits
 - Ability to cool down under 77 K (~ to 65 - 70 K)
 - Small space requirements
- Constraints
 - Electric power < 500 kW
 - Ambient cooling power required < 500 kW
 - Liquid nitrogen ~ 100 m³ onsite storage
 - 2 x 30 m³ trailer per day can be supplied

- **Proposed solution**

- Combination of LN2 heat exchanger and “cycle cooler”
 - ~ 200 kW LN2 heat exchanger to get massive power for cooldown
 - ~ 5 - 10 kW “cycle cooler” (Stirling, J-T, G-M, ...) for steady state and “subcooling”
 - Modular design preferred

- In current stage of design, all pipes are routed to one location on the bottom lid of tokamak cryostat. Underneath that separate coldbox should be located.
- Coldbox should include all sensors (coolant thermometers, flowmeters, pressure sensors) and all needed control/isolation valves.
- There can be multiple coldboxes (for example one for circulators, second for heat exchangers...)

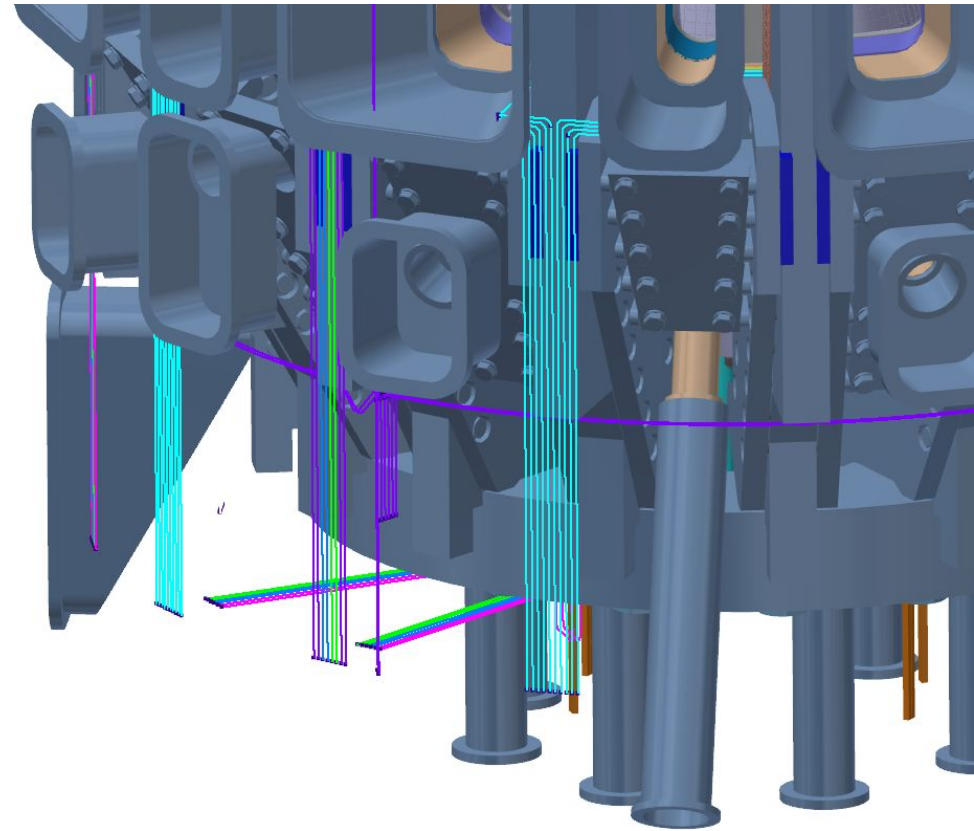
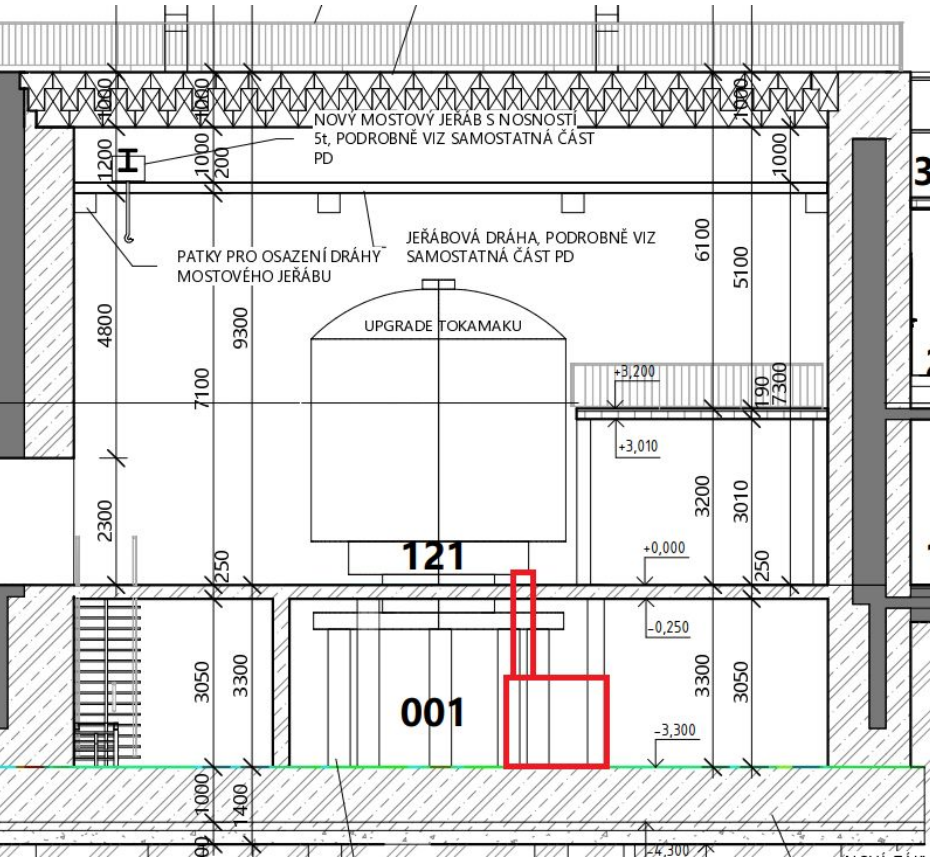

Fig. 12.: Overview of tokamak hall with coldbox in red (2 x 2 meters)

Fig. 13.: Overview of cooling pipes routing to one location.

- Available interfaces will be
 - **Electricity**
 - 400 V
 - Available power for cryogenics ~ 100 - 200 kW
 - **Water / glycol cooling**
 - Cooling power ~ 100 - 200 kW
 - Base temperature ~ 10 °C
 - **Demineralized water cooling**
 - Cooling power ~ 10 kW
 - Ultra pure, nitrogen buffered, continuously measured conductivity
 - **Liquid nitrogen**
 - ~ 100 m³ storage onsite
 - **Compressed air**
 - 10 bar

- Cryogenic control system should be a **stand alone system**.
 - This should include interlocks, fault handling, process variable logging, etc.
 - Interface will be present to connect cryogenic system to tokamak central control system.
 - Setting operation modes / temperatures, overviewing current state / faults...
- Most sensors will be part of the tender
 - Except temperature sensors inside cryostat (coil/structure/etc temperature sensors) will be supplied by IPP and cryosystem must be able to interface them.
 - Sensors need to have **sufficient precision** to obtain requested limits (max 40 K difference between coolant and cooled part, cooldown in 30 minutes, etc...) - we think that thermometer precision 1 - 2 K is sufficient.
- All actuators will be part of tender
 - In case of **redundant cooling channels** (for example in TF coils), ability to **evacuate** and **seal damaged channel** is required.
 - During tokamak operation (during shot itself), stray magnetic field will be present. If any electromagnet-actuated valve is used, it must be verified that this stray field will not affect its performance.

- Cryogenic system will include **inventory control system** which will
 - Automatically **fill or discharge medium** during operation to keep pressure in set range.
 - **Compress medium back** to reservoir for system maintenance periods.
- System should include precautions to keep medium purity
 - Chance of contaminants to **cause blockage** in one of the cooling channels must be **minimized!**
 - Cooling channels will include **ceramic brakes** to electrically insulate coils from rest of cryogenic system. Working voltage across those insulation gaps will be 1 kV. Attention must be paid to any contaminants possible to **short out this isolation barrier!**
 - Circulator bearings doesn't have to be oil-free, if proper filters are introduced in system.

- In the tokamak hall, **neutron flux** during discharge will be present.
 - Total neutron dose ~ up to 5 000 Sv per year.
 - We don't require absolute neutron protection, however radiation should not cause "expensive" faults like destruction of circulator or tokamak.
 - It is possible to locate sensitive components (high power circulator drivers, etc...) out of tokamak hall. Distance from shielded space to coldbox is ~10 meters.
- **Stray magnetic field** will be present during the tokamak discharge.
 - Magnetic field intensity < 60 mT.
 - Presence of magnetic field should not cause any destructive fault of electronics or uncontrolled opening of valves.

Because of budgetary/time/space constraints, tokamak and cryosystem will be probably procured in phases. It must be possible to extend the cryogenic system from one phase to the next one.

If the price difference between Phase 0 and Phase 1 will be small enough, Phase 0 may be omitted...

It's expected that there will be separate tenders for each phase.

- **Phase 0 - initial commissioning**

- Limited cooling capabilities
 - required cooling power < 20 kW
 - no subcooling
- Limited circuit redundancy
 - One circulator, all cooling loops in parallel

- **Phase 1 - full power**

- Full power shot once per 60 minutes (cooldown time < 60 minutes)
- All circulators needed, full redundancy
- ~100 kW of cooling power @80 K

- **Phase 2 - future improvement**

- Full power shot once per 30 minutes (cooldown time < 30 minutes)
- Hydrogen as coolant probably needed for reaching this
- ~200 kW of cooling power required @80 K

- Cryogenic system will be supplied by **one supplier**.
- Tender will be public, according to Czech legislation
- Cryogenic system will include
 - Coldbox and all sensors / actuators
 - All piping up to requested interface
 - Circulators, cold sources, heat exchangers
 - Coolant inventory management system
 - Control system
- Interfaces will be described in tender
 - Interface to **tokamak** will be **between cryostat and coldbox**.
 - Interface to **building systems** will also **be specified** in tender.
- We will **require** thorough **documentation** of system and **source codes** of all software.
 - With appropriate NDA or IP agreement.

- What cooling topology would you suggest?
- What operation ranges (pressures, densities) and efficiencies can you get from your circulators?
- Can you estimate size of all system components? (circulators, cold source, heat exchangers, inventory management, ...)
- What is estimated tightness of complete system? How much of helium per day will be needed to add?
- Can you estimate (order of) cost of such system, component-wise? What are possible optimizations for lowering the price?
- What refrigerator would you suggest on using and why?
- *Not directly related to cooling system* - Do you have any experience with high temperature vacuum MLI (multi-layer insulation)?