

Scanning electron microscopy and microanalysis

Electron microanalysis performed on the surface of the earring (*Fig. 4/37b, c, e*) showed that the central wire of the earring and the clamp were made of pure copper while the beaded and smooth filigree rings were made of a copper alloy containing a small amount of tin (3.7 to 8.2 %) and arsenic (1.2 to 2 %) (Table 51). The different components of the earring are soldered together with a hard solder containing 78 % of silver and 22 % of copper. The whole earring was gilded by fire-gilding. The amalgam also contains up to 5.5 % silver. The porous structure of fire-gilded surface was observed under scanning electron microscope (*Fig. 4/37d*).

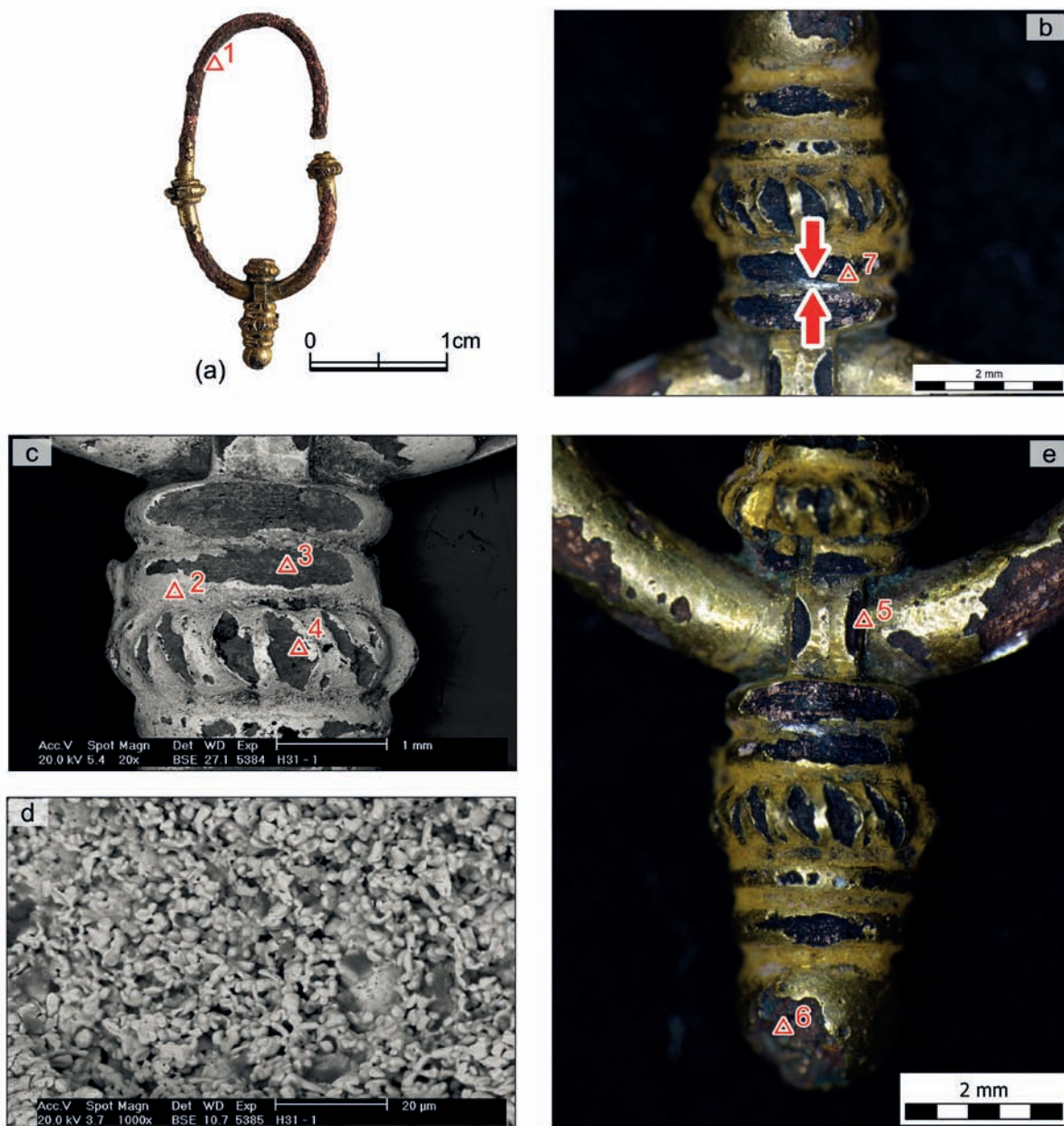

Fig. 4/37: Earring H31-1: a - general view of the earring (photo J. Sobek); b - analysed solder (photo E. Ottenwelter); c - detail of the lower grape with analysed components, SEM micrograph (BSE image, photo D. Janová); d - gilding layer in recess, SEM micrograph (BSE image, photo D. Janová); e - detail of the grapes fixed to the central wire with a clamp (photo E. Ottenwelter).

Obr. 4/37: Náušnice H31-1: celkový pohled na náušnici (foto J. Sobek); b - analyzovaná pájka (foto E. Ottenwelter); c - detail spodního hrozníčku s vyznačením míst bodové mikroanalýzy, mikrosnímek z rastrovacího elektronového mikroskopu (zobrazení BSE, snímek D. Janová); d - vzhled vrstvy zlatení v prohlubních, mikrosnímek z rastrovacího elektronového mikroskopu (zobrazení BSE, snímek D. Janová); e - detail hrozníčků, upevněných poutkem ke středovému drátu (foto E. Ottenwelter).

Components forming the grape-shaped earring H31-1	Chemical composition [Wt. %]							
	Au	Ag	Cu	Hg	Sn	As	Zn	O
Central wire, bulk metal, point 1	-	-	100	-	-	-	-	-
Gilding layer in recess, point 2	75.2	5.5	4.6	14.7	-	-	-	-
Bulk metal, smooth filigree, point 3	14.5	3.3	63.6	-	8.2	2	-	8.4
Bulk metal beaded filigree, point 4	4.5	-	86.3	-	3.7	1.2	0.2	4.1
Bulk metal clamp, point 5	8.5	3.1	83.9	-	-	-	-	4.5
Bulk metal, big granule, point 6	-	-	100	-	-	-	-	-
Solder area between filigree rings, point 7	-	78	22	-	-	-	-	-

Table 51: Chemical composition of the different elements composing the earring H31-1 and solder area.

Tab. 51: Chemické složení různých částí náušnice H31-1 a složení pájených částí.

5. BEADS

The metallic beads recovered from the “Lumbe Garden“ cemetery were found as components of necklaces together with glass and semi-precious stones beads or separately.

All the beads are constructed around a central unit formed by two symmetrical halves in plain sheet metal or open filigree work on which different decorative elements are soldered (filigree, granules, applied bosses, glass cabochons). Eight types of beads are present in the set and were analysed (Fig. 4/38).

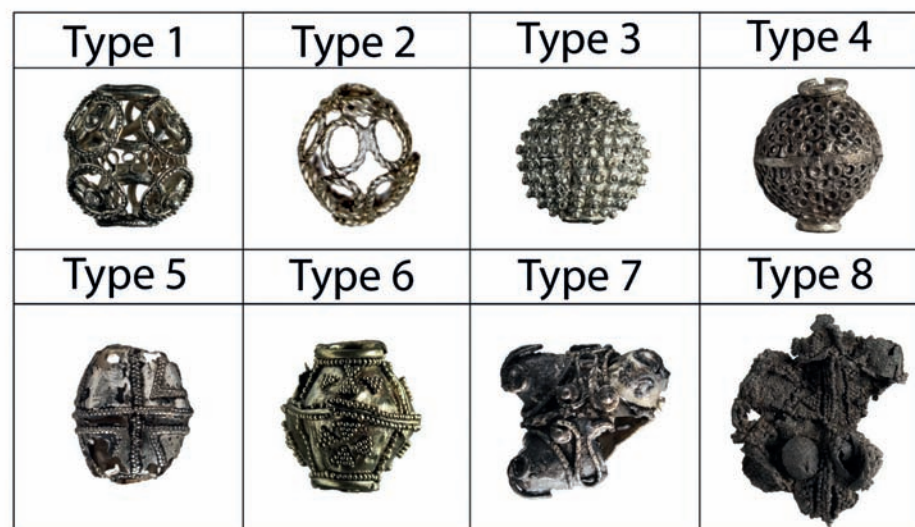

Fig. 4/38: Summarizing table of the different types of beads analysed: type 1 - bead in open filigree and granulation work (H100-27): Ag-Au-Cu alloy, 8 different kinds of components; type 2 - bead in open filigree work with twisted wires rings (H82-13): Ag-Cu alloy, 3 different kinds of components; type 3 - spherical bead covered by granules sitting in a filigree ring (H100-18): Ag-Cu alloy, 4 different kinds of components; type 4 - quadrilobed bead fully covered by small filigree rings (H5-3): Ag-Cu alloy, 4 different kinds of components; type 5 - quadrilobed hemispheres with double line of granulation decoration (H25-2): Ag-Cu alloy, 3 different kinds of components; type 6 - trilobed hemispheres bead with granulation work in form of Maltese crosses (H16-18): Au-Ag-Cu alloy, 3 different kinds of components; type 7 - bead with applied bosses and filigree work (H53-18): Ag-Cu alloy, 9 different kinds of components; type 8 - bead with applied bosses and granulation work (H116A-3): probably Ag-Cu alloy, 5 different kinds of components.

← **Obr. 4/38:** Souhrnný přehled různých typů analyzovaných perel: typ 1 – perla zhotovená volnou filigránovou technikou a granulací (H100-27): slitina Ag-Au-Cu, složená z osmi různých druhů komponent; typ 2 - perla zhotovená volnou filigránovou technikou z kroužků z tordovaného drátu (H82-13): slitina Ag-Cu, složená ze tří různých druhů komponent; typ 3 – kulovitá perla pokrytá granulemi, sedícími ve filigránovém kroužku (H100-18): slitina Ag-Cu, složená ze čtyř různých druhů komponent; typ 4 – čtyřlaločná perla zcela pokrytá malými filigránovými kroužky (H5-3): slitina Ag-Cu, složená ze čtyř různých druhů komponent; typ 5 – čtyřlaločné hemisféry se zdvojenou linií granulační dekorace (H25-2): slitina Ag-Cu, složená ze tří různých druhů komponent; typ 6 – perla ze dvou trojlaločných hemisfér a granulací ve tvaru maltezkých křížů (H16-18): slitina Au-Ag-Cu, složená ze tří různých druhů komponent; typ 7 – perla s pukličkami a filigránem (H53-18): slitina Ag-Cu, složená z devíti různých druhů komponent; typ 8 - perla s pukličkami a granulací (H116A-3): pravděpodobně slitina Ag-Cu, složená z pěti různých druhů komponent.

5.1. BEAD MADE IN OPEN FILIGREE AND GRANULATION WORK (TYPE 1)

This type of bead includes two specimens found in grave H100 (H100-20 and H100-27) where a woman was buried. They are part of a necklace made of four metallic beads and semi-precious stones beads (Frolík - Smetánka 2014, p. 168-171).

Description of the bead H100-27 (Fig. 4/39)

The bead has open filigree work (Fig. 4/40a, b). It is an oval shape with a maximum diameter of 10.3 mm and a length of 12.3 mm. It consists of two hemispheres, connected together by a ring of corrugated strip (Fig. 4/39-C) of 0.2 mm in width (Fig. 4/40c, f). Each hemisphere consists of two components reminiscent of the Greek letter “omega” (Fig. 4/39-B) and made from a bent round-

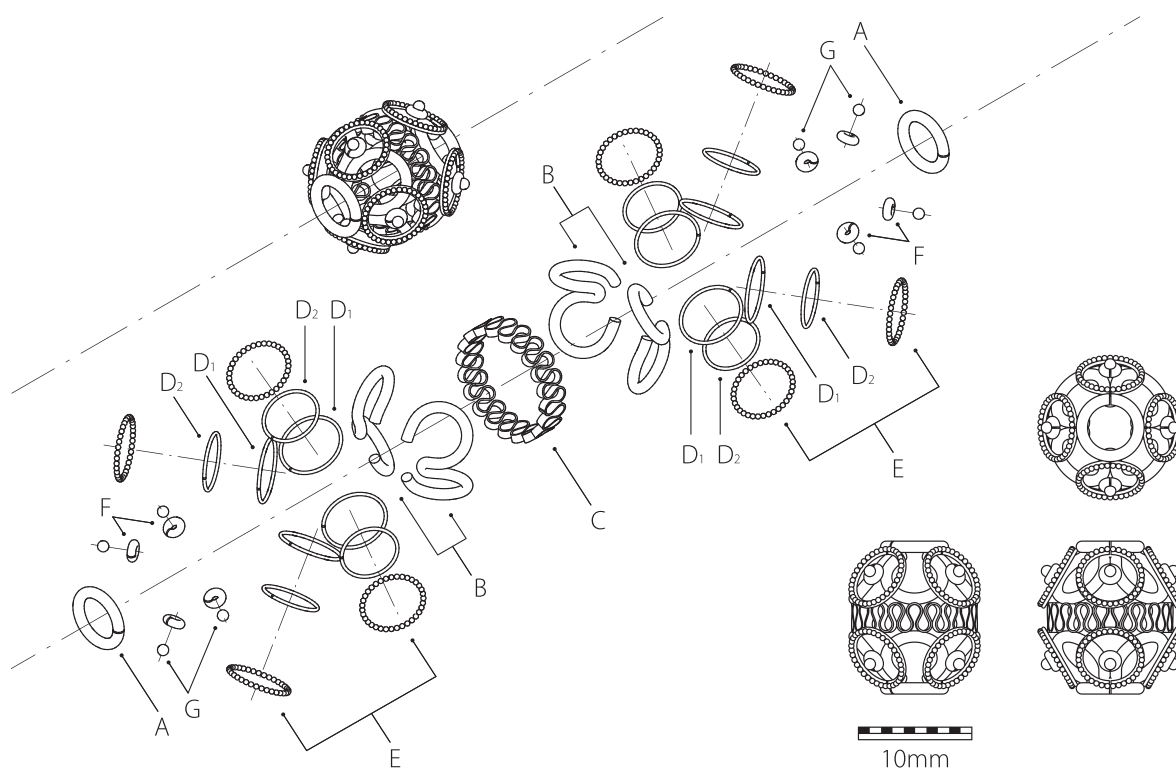

Fig. 4/39: Bead H100-27: exploded view of the bead showing the different components composing the bead: A - ring; B - components reminiscent of the Greek letter omega; C - ring of corrugated strip; D - thinner rings; E - small granules; F - small filigree rings; G - big granules (drawing G. Plítková).

Obr. 4/39: Perla 100-27: schématické znázornění jednotlivých komponent rozložené sestavy perly: A - kroužek; B - komponenta připomínající řecké písmeno omega; C - kroužek z meandrovitě zvlněného pásku; D - tenčí kroužky; E - malé granule; F - malé filigránové kroužky; G - velké granule (kresba G. Plítková).

sectioned wire of 0.8 mm in diameter soldered together at the ends, topped by a ring made from a round-sectioned wire of the same diameter (*Fig. 4/39-A*), and shaped on a lead block (see *Barčáková* in this volume). Each hemisphere bears a decoration of four rings made of two thinner round-sectioned wire rings (0.2 mm in diameter) soldered together (*Fig. 4/39-D₁-D₂*) and decorated with a line of granules of 0.3 mm in diameter (*Fig. 4/39-E, 4/40d, e*). The imaginary centres of the decorated rings (*Fig. 4/39-D₁-D₂*) are placed on contact parts of inner construction omega shapes (*Fig. 4/39-B*) and a smaller round-sectioned wire ring (*Fig. 4/39-F*) of 0.3 mm in diameter topped by one big granule (*Fig. 4/39-G*) of 0.3 mm in diameter is placed at their position. A total of eight different kinds of components had to be manufactured to form this bead.

Bead H100-27		Dimension [mm]
Wire (B)	Ø	0.8
Wire (A)	Ø	0.8
Wire (A)	Ø	1.1
Strip (C)	width	0.7
Strip (C)	thickness	1
Wire (D ₁ , D ₂)	Ø	0.2
Wire (F)	Ø	0.4
Ring (A)	Ø	5
Ring (D ₁ , D ₂)	Ø	5
Big single granule (G)	Ø	1.3
Small granules on ring (E)	Ø	0.3

Table 52: Dimensions of the different components of the bead H100-27.

Tab. 52: Rozměry jednotlivých částí perly H100-27.

Condition of the bead and quality of the work

The condition of the bead is rather good. A good metallic core is still preserved on most of the elements composing the bead except for the corrugated strip which appears extremely brittle and which is not complete. However, the bead surface is heavily etched due to past chemical treatment. Severe intergranular corrosion has occurred, especially in the corrugated strip resulting in cracks along the grain boundaries and weakening of the cohesion of the artefact (*Fig. 4/40g*). The loss of entire grains of silver was observed on the polished cross-section of the corrugated strip (*Fig. 4/40h*).

The overall quality of the bead is excellent. This jewel is one of the most difficult jewels to manufacture from the set of the “Lumbe Garden” cemetery (see *Barčáková* in this volume).

Scanning electron microscopy and microanalysis

Electron microanalysis showed that all parts, with the exception of the small granules (*Fig. 4/39-E*) and upper and bottom closed rings (*Fig. 4/39-A*), were produced from one type of Ag-Au-Cu alloy with approximately 3% by weight of both copper and gold (Table 53). The small granules (*Fig. 4/39-E*) exhibit slightly less copper content and the bottom and top rings (*Fig. 4/39-A*) are made of a binary Ag-Cu alloy.

Components forming the bead H100-27	Chemical composition [Wt. %]		
	Ag	Cu	Au
Wire (B)	94.4	2.9	2.7
Wire (A)	97.3	2.7	n. d.
Strip (C)	94.1	2.9	3
Wire (D ₁ , D ₂)	93.7	2.8	3.5
Wire (F)	93.7	3.3	3
Big single granule (G)	93	4	3
Small granules on ring (E)	95.5	1.7	2.8

Table 53: Chemical composition of the different elements forming the bead H10027.

Tab. 53: Chemické složení různých částí perly H100-27.

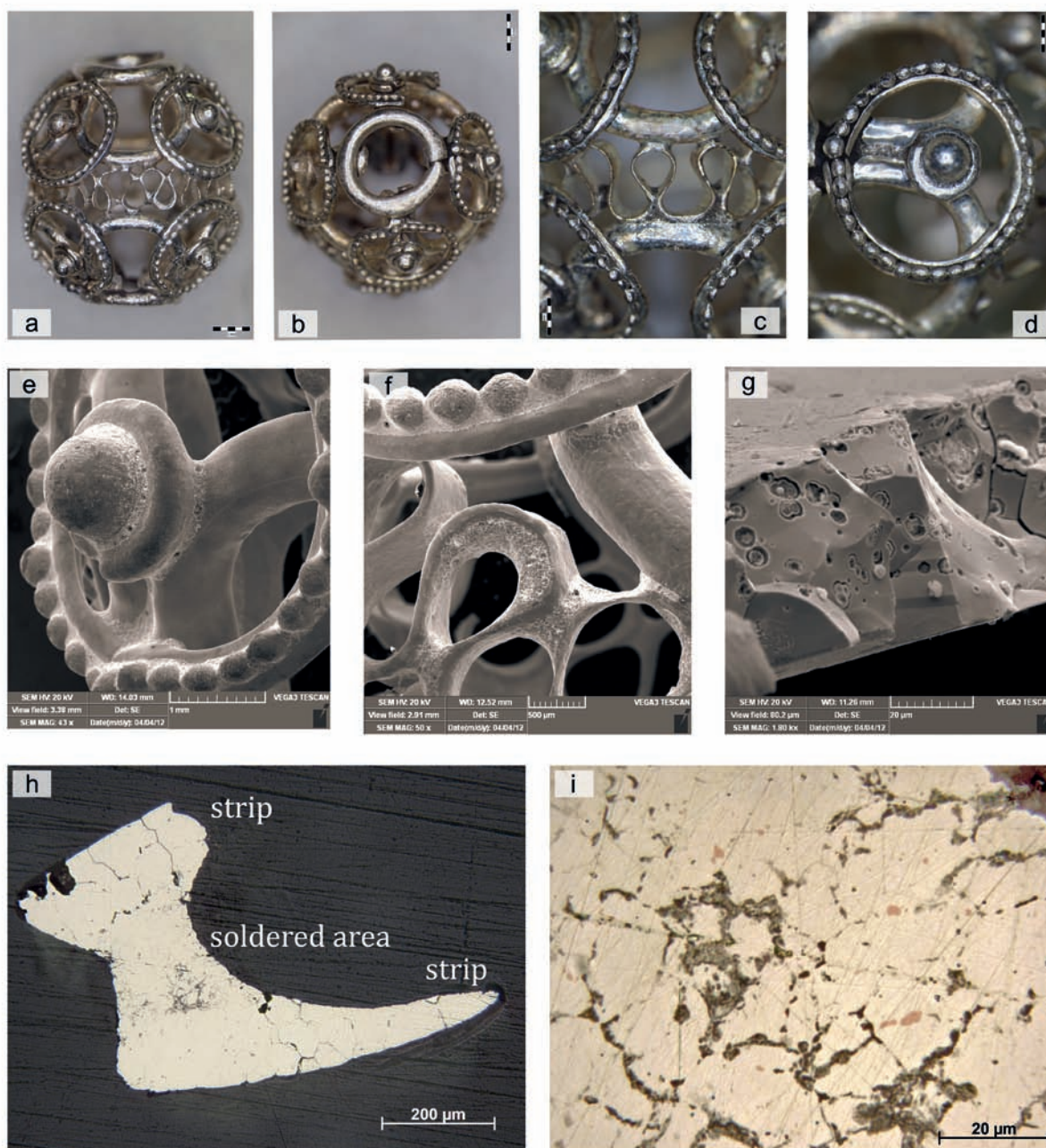

Fig. 4/40: Bead H100-27: a-b - side and top view of the bead (photo E. Ottenwelter); c - detail of the corrugated strip (photo E. Ottenwelter); d - detail of the rings topped by a row of granulation work (photo E. Ottenwelter); e - detail of the rings topped by granulation work, SEM micrograph (SE image, photo J. Děd); f - detail of the corrugated strip, SEM micrograph (SE image, photo J. Děd); g - fracture showing intergranular corrosion and twinned grains, SEM micrograph (SE image, photo J. Děd); h - optical microscopy documentation of polished unetched cross section of the corrugated strip fragment (photo J. Děd); i - polished sample of the corrugated strip showing the porosity of the solder area and the presence of reddish Cu - rich metallic particles (photo J. Děd).

Obr. 4/40: Perla H100-27: a-b – boční a horní pohled na perlu (foto E. Ottenwelter); c - detail zvlněného pásku (foto E. Ottenwelter); d - detail kroužků osázených na horní ploše řadou granulí (foto E. Ottenwelter); e - detail detail kroužků osázených na horní ploše řadou granulí, mikrosnímek z rastrovacího elektronového mikroskopu (zobrazení SE, snímek J. Děd); f - detail zvlněného pásku, mikrosnímek z rastrovacího elektronového mikroskopu (zobrazení SE, snímek J. Děd); g - fazeta interkrystalického lomu, dokumentující korozní napadení po hranicích zrn, patrné rovněž dvojčatění krystalových zrn, mikrosnímek z rastrovacího elektronového mikroskopu (zobrazení SE, snímek J. Děd); h - nenaleptaný příčný metalografický výbrus fragmentu zvlněného pásku (snímek z optického mikroskopu J. Děd); i - metalografický výbrus fragmentu zvlněného pásku – porézní oblast pájeného spoje s přítomností červenavých, mědi bohatých částic (snímek z optického mikroskopu J. Děd).

The composition of the material in soldered area was determined by a metallographic section of an available fragment from the corrugated strip (Table 54).

Corrugated strip fragment	Chemical composition [Wt. %]		
	Cu	Au	Ag
Fragment of the corrugated strip homogeneous solder (cross section)	6.2	4.1	89.7
Red metallic particles in the solder area	67.6	7.9	24.5
Strip base metal	2.8	2.7	94.5

Table 54: Average chemical composition of the homogeneous solder area determined at corrugated strip cross section.

Tab. 54: Průměrné chemické složení řezu homogenním pájeným spojem na zvlněné pásce.

The fragment of the corrugated strip which fell down after unvarnishing the bead with acetone was used for metallographic analysis. This fragment as well as the soldered area between two loops of the corrugated strip was embedded in epoxy resin and polished (*Fig. 4/40h*).

Both loops of the corrugated strip exhibit a fully recrystallized coarse-grained structure visible even in its unetched state due to an extensive intergranular corrosion attack (*Fig. 4/39h*). Scanning electron microscope documentation of the strip (*Fig. 4/40g*) also showed a fully recrystallized coarse-grained structure as well as twinned grain which is characteristic of cold worked and annealed metal.

The structure of the intermediate soldered area is believed to be a cast structure. This region is rather porous (*Fig. 4/40i*).

Electron microanalyses performed on the cross section of the soldered joint between the two loops of the corrugated strip evidenced the composition of the soldered area (89.7 % Ag, 6.3 % Cu, 4 % Au) and corrugated strip base metal (Table 54). The soldered area exhibits a slightly higher content of gold (1 % more) and increase of copper content (3.5 % more) in the homogeneous solder area in comparison with the metal composition (Table 54). The enrichment of gold on the surface was also highlighted by EDS line analysis of the cross section (*Děd – Ottenwelter – Barčáková, in press*).

Metallographic analysis also evidenced the presence of reddish metallic undissolved particles (*Fig. 4/40i*) in the soldered area with a high amount of copper (60 to 70 %, 25 % to 30 % of silver and approximately 8 % of gold - Table 54) which tends to demonstrate that fine metallic particles of copper alloyed with silver and gold were probably used to create the solder.

5.2. BEAD IN OPEN WORK FILIGREE WITH TWISTED WIRE RINGS (TYPE 2)

This type of bead is made of filigree rings made with twisted wires. It was found as part of the metallic necklace found in grave H82. The necklace bears five beads of this type (*Frolík - Smetánka 2014, p. 146-151*).

Description of the bead H82-13 (*Fig. 4/41*)

The bead is an open filigree work formed by rings of double twisted wires. Two hemispheres (*Fig. 4/41-C*) made up of 6 round-sectioned, double twisted, wire, oval rings comprise each of them and are topped by two rings (*Fig. 4/41A-B*) of different diameters soldered together to form an oval shape bead of about 11 mm in length and 9 mm in width. The round-sectioned wires used to form the double twisted wire rings all have the same diameter of 0.3 mm. Three kinds of rings were manufactured to produce the bead.

The bead was mounted to the metallic chains of the necklace by three loops shaped into oval links (*Fig. 4/42-A*) of 15 mm in length and made with a round wire of 0.4 mm in diameter. The chain is made from a single loop-in-loop system (*Untracht 1982, p. 192-193*). Each link (*Fig. 4/42-B*) is made from circular loops made with a round-sectioned wire of 0.4 mm in diameter wrapped around a wooden dowel and cut. Each loop was soldered and shaped into ovals and folded in two (see *Barčáková* in this volume). Each soldered and folded loop is interlinked with the following loop.

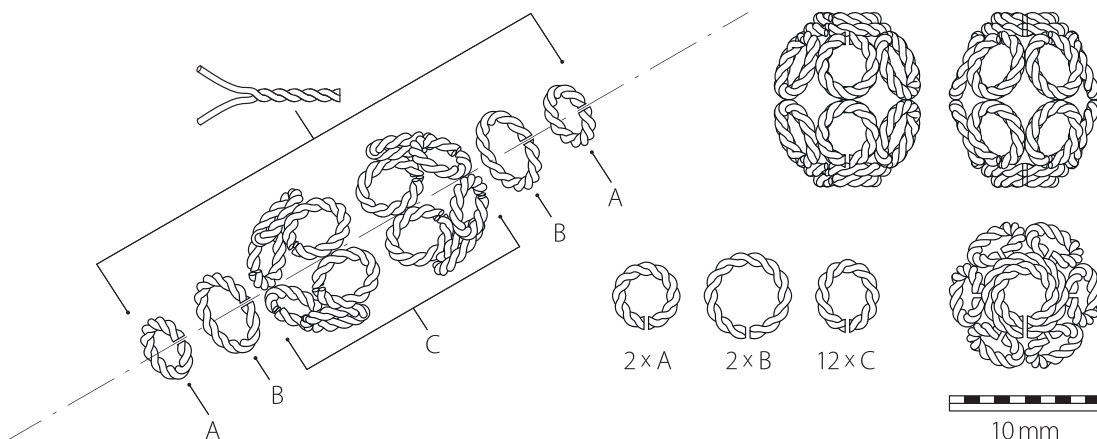

Fig. 4/41: Bead H82-13: exploded view showing the different components composing the bead: A - small external rings; B - big external rings; C - rings forming hemispheres (drawing G. Plítková).

Obr. 4/41: Perla H82-13: schématické znázornění jednotlivých komponent rozložené sestavy perly: A – malé vnější kroužky; B – velké vnější kroužky; C – kroužky tvořící hemisféry (kresba G. Plítková).

Condition of the beads and the chain and quality of work

Three beads out of five are complete, while two are preserved only partly. The chain was already restored. Missing links were replaced by new ones (Fig. 4/43d). The original links are very brittle and, in some cases, were still covered by silver corrosion products - mainly sulphides and chlorides (Fig. 4/43b).

This type of chain is the simplest type of chain to manufacture. The beads are well manufactured.

Scanning electron microscopy and microanalysis

The wires used to make the rings are silver alloys containing 3 to 5.6 % of copper. The surface analysis performed on the soldered area did not highlight a higher content of copper (Table 56).

Bead H82-13		Dimensions [mm]
Total	length	11
Total	width	9
Ring (A)	Ø	3.6
Ring (B)	Ø	4.4
Ring (C)	length	4.5
Wire used to make the double twisted rings	Ø	0.3

Table 55: Dimensions of the different components of the bead H82-13.

Tab. 55: Rozměry různých částí perly H82-13.

Bead H82-13	Chemical composition [Wt. %]			
	Cu	Ag	Cl	S
Wire 1 (fresh break)	5.6	94.4	-	-
Wire 2 (fresh break)	3	97	-	-
Solder area	3.2	92.9	2.3	1.6

Table 56: Chemical composition performed on a fragment of a twisted wire forming a ring (Fig 4/41-C) from the bead.

Tab. 56: Chemické složení fragmentu torzovaného drátu, z něhož je vytvořen kroužek (Obr. 4/41-C).

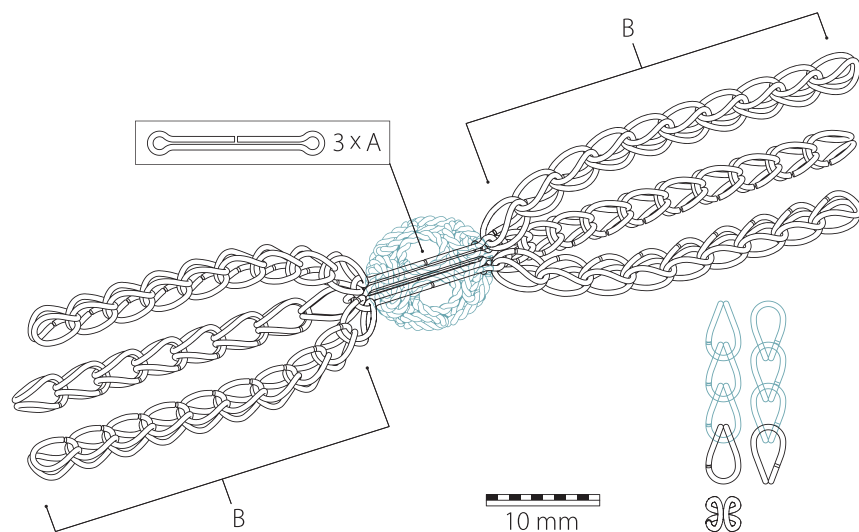

Fig. 4/42: Chain H82-13: exploded view showing the oval links on which were mounted the bead and the chain: A - internal bead links; B - chain links (drawing G.Plítková).

Obr. 4/42: Řetízek H82-13: schématické znázornění jednotlivých komponent - oválné články, na které byla upevněna perla a řetízek: A - vnitřní články perly; B - články řetízku (kresba G.Plítková).

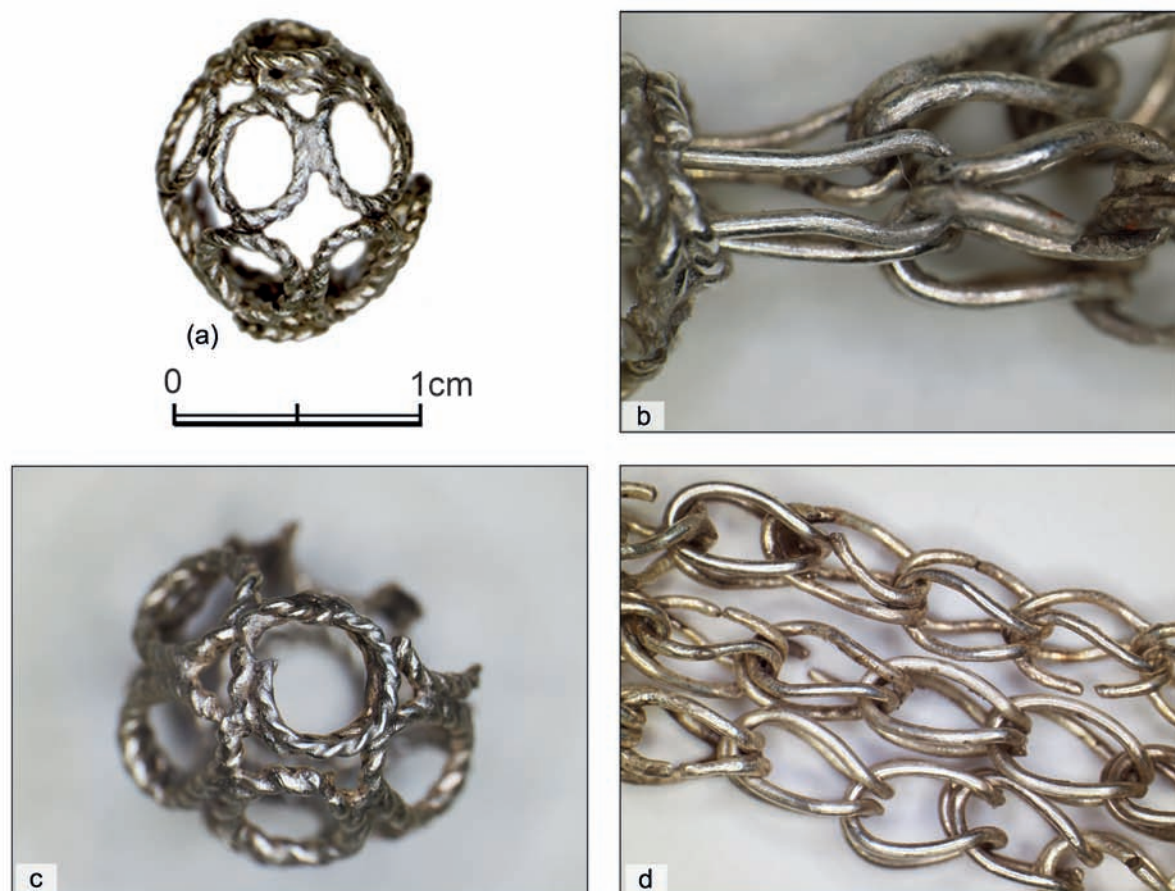

Fig. 4/43: Bead H82-13: a - general view of the bead; b - oval links inserted in the three chains; c - top view of the bead ; d - detail of the triple strand loop in loop chain (photos E. Ottenwelter).

Obr. 4/43: Perla H82-13: a - celkový pohled na perlu; b - oválné články vložené do tří řetízků; c - horní pohled na perlu; d - detail třípramenného řetízku (fotografie E. Ottenwelter).

Chain H82-13	Chemical composition [Wt. %]	
	Cu	Ag
Internal oval link (A)	2.3	97.7
Chain link (B)	2.4	97.6

Table 57: Chemical composition of the internal bead link and chain link.

Tab. 57: Chemické složení vnitřního článku perla a článku řetízku.

The alloy used to manufacture the chain links and internal bead link is silver with 2.4 % of copper which is similar to the alloy used to manufacture one type of wire from the bead (Table 57).

5.3. SPHERICAL BEAD FULLY COVERED BY GRANULES SITTING IN A FILIGREE RING (TYPE 3)

These beads were retrieved in grave H100. They were also part of the necklace described above. Two identical specimens are present (H100-18 and H100-29). Both are made of a silver alloy.

Description of the bead H100-18 (Fig. 4/44)

The bead is hollow. It has a spherical shape with a diameter of 10.3 mm. It is composed of two thin sheet hemispheres (Fig. 4/44-A) shaped with a dapping tool and a lead block, soldered together, and pierced on each side. Each perforation has a round-sectioned wire ring (Fig. 4/44-B) of 3.4 mm in diameter around it. Each hemisphere is decorated by five concentric rows of granules of 0.5 mm in diameter (Fig. 4/44-E) sitting on a small ring (Fig. 4/44-C) of smooth, circular-sectioned wire of 0.1 mm in diameter. Four different types of components were manufactured to form the bead.

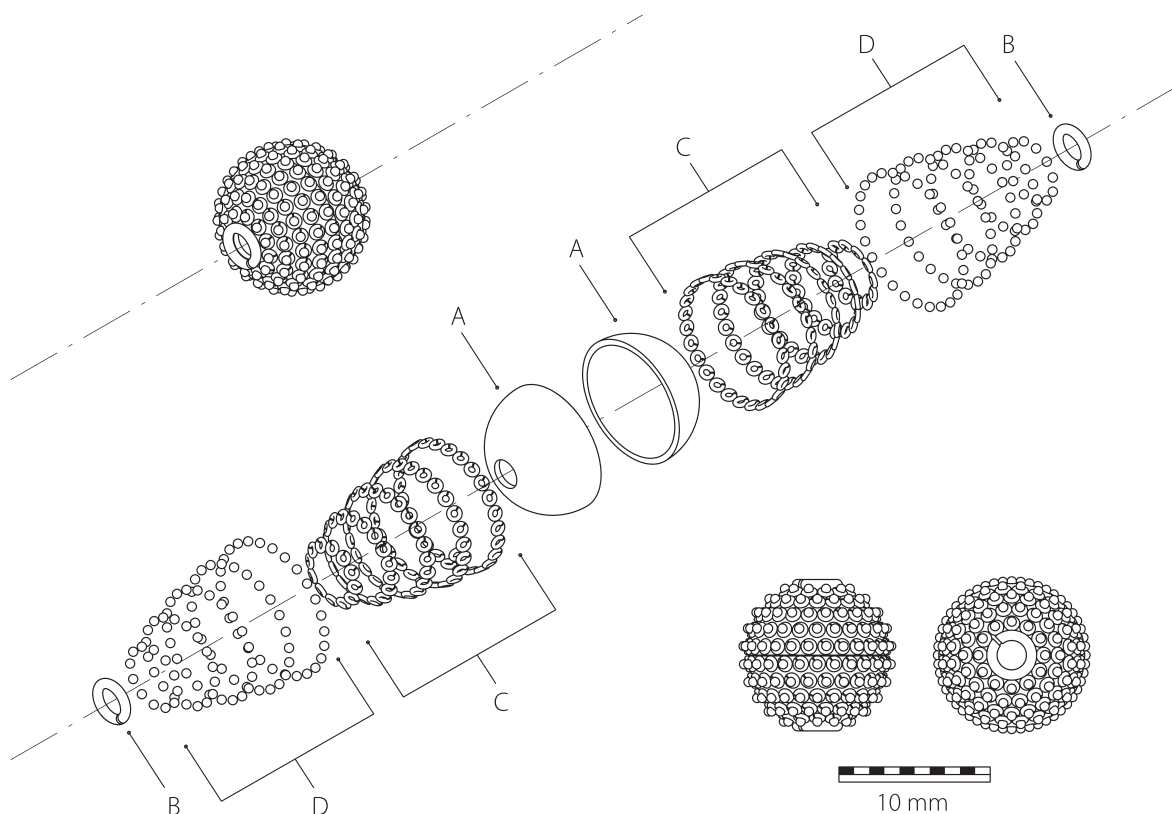

Fig. 4/44: Bead H100-18: exploded view of the bead showing the different components composing the bead: A - hemispheres; B - rings around perforation; C - filigree rings; D - small granules (drawing G. Plítková).

Obr. 4/44: Perla H100-18: schématické znázornění jednotlivých komponent rozložené sestavy perly: A - hemisféry; B - kroužky kolem perforace; C - filigránové kroužky; D - malé granule (kresba G. Plítková).

Bead H100-18	Diameter [mm]
	average
Ring (B)	3.4
Wire (B)	0.6
Filigree ring (C)	1
Wire (C)	0.1
Small granules (D)	0.5
Pearl	10.3

Table 58: Dimensions of the different components of the bead H100-18.

Tab. 58: Rozměry jednotlivých částí perly H100-18.

Condition of the bead and quality of the work

The bead is complete (*Fig. 4/45a*) though the limit of the original surface is gone because of invasive past chemical treatment by immersion in alkaline cyanides. Part of the granule have been dissolved, some have fallen off and are missing (*Fig. 4/45b, c, d*).

The quality of the work is good.

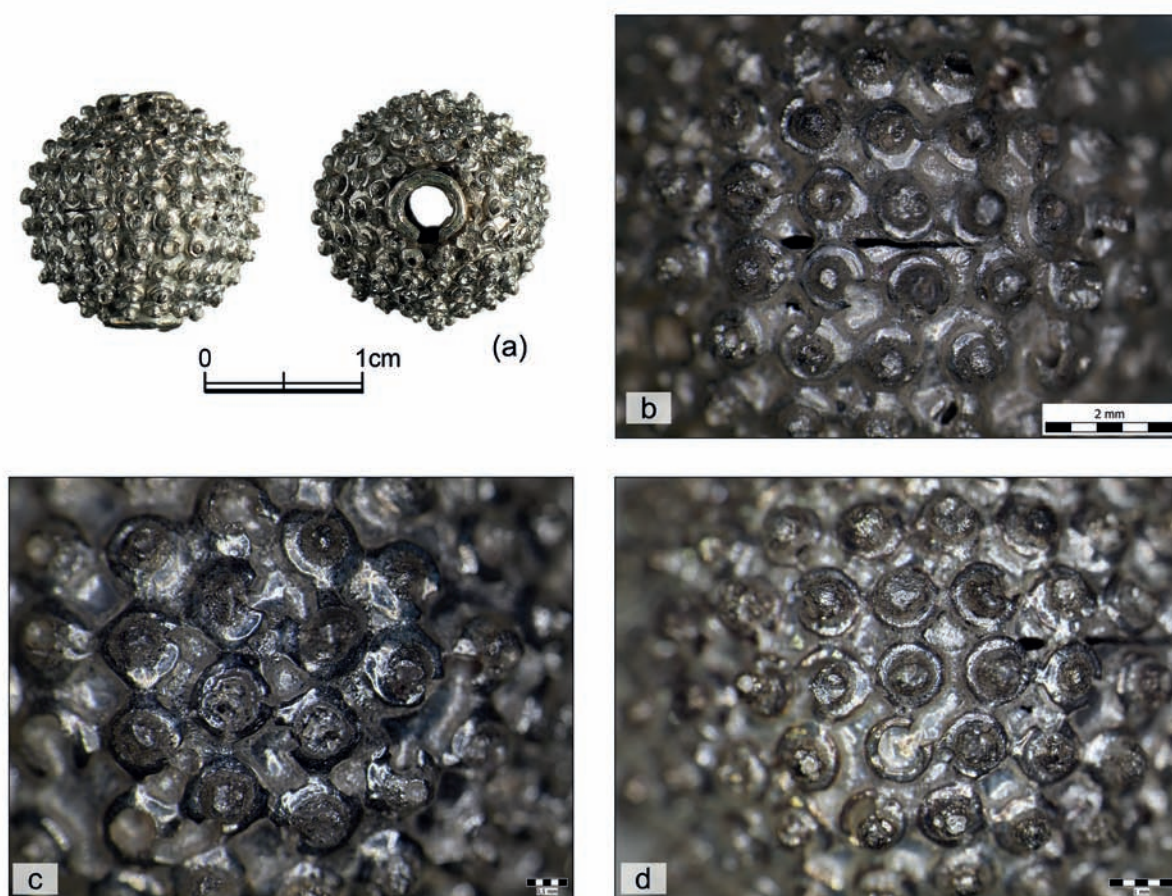

Fig. 4/45: Bead H100-18: a - general view of the bead (photo J. Sobek); b - joining area of the two hemispheres (photo E. Ottenwelter); c - detail of the granulation work (photo E. Ottenwelter); d - detail of the granulation work (photo E. Ottenwelter).

Obr. 4/45: Perla H100-18: a - celkový pohled na perlu (foto J. Sobek); b - oblast spoje dvou hemisfér (foto E. Ottenwelter); c - detail granulace (foto E. Ottenwelter); d - detail granulace (foto E. Ottenwelter).

Scanning electron microscopy and microanalysis

Electron microanalysis showed that the hemispheres (*Fig. 4/44-A*) and the rings (*Fig. 4/44-B-C*) were produced with a binary Ag-Cu alloy with approximately 1.7-2 % of copper (Table 59). Higher content of copper was detected on small granules (*Fig. 4/44-D*) and of course in areas where the occurrence of solder is evident or assumed. In these cases, copper content is higher than 3 %.

Components forming the bead H100-18	Chemical composition [Wt. %]		
	Ag	Cu	S
Hemisphere (A)	98	2	n. d
Ring (B)	98.7	1.7	n. d
Filigree rings (C)	97	1.9	1. 1
Small granules (D)	94.9	3.3	1
Solder area (between filigree wire and ends) (C)	96.3	3.7	n. d
Solder area (between two filigree rings) (C)	96.6	3.4	n. d
Solder area (between the two hemispheres) (A)	96.8	3.2	n. d
Solder area (between hemisphere A and ring B)	95.7	4.3	n. d

Table 59: Chemical composition of the different elements forming the bead H100-18.

Tab. 59: Chemické složení jednotlivých částí perly H100-18.

5.4. QUADRILOBED BEAD FULLY COVERED BY SMALL FILIGREE RINGS (TYPE 4)

Decription of the bead H5-3 (*Fig. 4/46*)

The bead H5-3 is a variation of the previous bead. It has nearly the same construction, however it is not formed by the joining of two spherical hemispheres but of two quadrilobed hemispheres. Futhermore, in this case, a thin strip is covering the joining area between the hemispheres and the small filigree rings covering the surface of the bead have no granules sitting on them (*Fig. 4/46a*). Two other beads from the same grave (H5-4 and H5-5) were in a very poor state of preservation but were probably of the same type except for the fact that bead H5-4 has a strip covering the joining area made of a filigree decoration made of two twisted, thin wires. This bead was manufactured with four different kinds of components.

Bead H5-3		Dimensions [mm]
Total length		13.8
Total width		12.3
Big ring	Ø	4.8
Big ring's wire	Ø	1
Small ring on the surface	Ø	1.4
Wire from the small ring	Ø	0.3
Hemisphere	thickness	0.2

Table 60: Dimensions of the different components of the bead H5-3.

Tab. 60: Rozměry jednotlivých částí perly H5-3.

Condition of the bead and quality of the work

The bead is not complete. A third of it is missing. The surface is heavily etched by previous chemical treatment with alkaline cyanides revealing a fully-recrystallized, grained structure as well as twinned grains typical of metallic artefacts manufactured by cold working followed by annealing (Fig. 4/46b, c, d).

Scanning electron microscopy and microanalysis

Electron microanalysis performed on the surface and on a polished cross-section of an available fragment (see Kolářová – Děd – Ottenwelter in this volume) showed that a silver copper alloy containing 3.1 % of copper was used to manufacture the hemispheres, while a silver-copper alloy containing 4 % of copper was used to manufacture the filigree rings (Table 61). Copper particules were evidenced on a surface close to the solder area suggesting that copper compounds were used to form the solder.

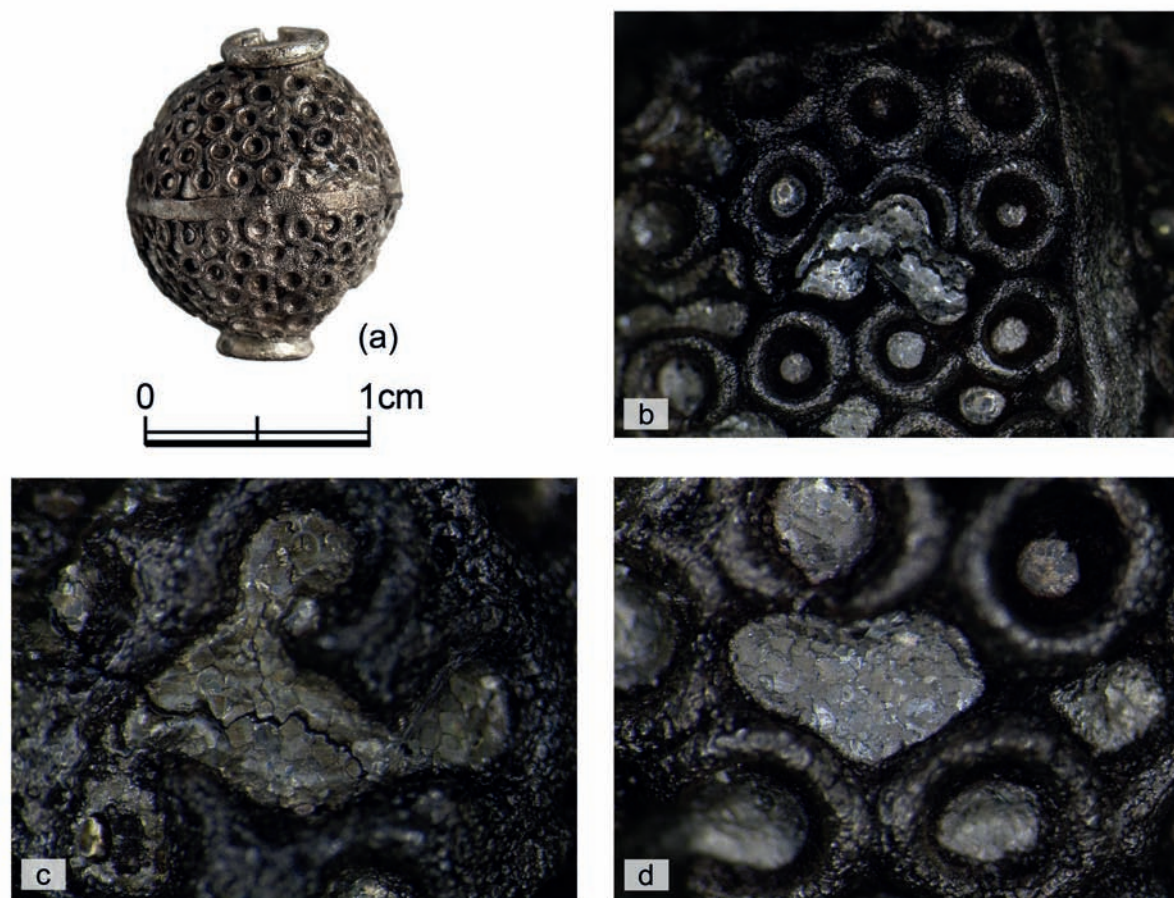

Fig. 4/46: Bead H5-3: a - general view of the bead (photo J. Sobek); b - detail of the filigree rings (photo E. Ottenwelter); c - intercrystalline crack (photo E. Ottenwelter); d - etched surface of the hemisphere (photo E. Ottenwelter).

Obr. 4/46: Perla H5-3: a - celkový pohled na perlu (foto J. Sobek); b - detail filigránových kroužků (foto E. Ottenwelter); c - interkrystalické trhliny na plášti perly (foto E. Ottenwelter); d - naleptaný povrch pláště perly (foto E. Ottenwelter).

Components forming the bead H5-3	Chemical composition [Wt. %]	
	Ag	Cu
Hemisphere (cross section)	96.9	3.1
Filigree rings (cross section)	96	4
Solder area (cross section)	78	22
Solder area (copper particules, cross section)	24.2	75.8

Table 61: Chemical composition of different elements forming the bead H5-3.

Tab. 61: Chemické složení jednotlivých částí perly H5-3.

5.5. QUADRILOBED HEMISPHERES BEAD WITH DOUBLE LINE OF GRANULATION DECORATION (TYPE 5)

This type of bead was found in grave H25 (Frolík - Smetánka 2014, p. 75-76). Only one specimen is known in the “Lumbe Garden” cemetery. It was made in silver.

Description of the bead H25-2 (Fig. 4/47)

The bead is hollow. It has an oval shape of 9.2 mm in diameter. It is composed of two extremely thin (44 µm), quadrilobed hemispheres (Fig. 4/47-A) soldered together and pierced on each side. Each perforation has a round-sectioned wire ring (Fig. 4/47-B) of 3 mm in diameter around it. Each hemisphere is decorated by double lines of granules (Fig. 4/47-E) of 0.3 mm in diameter forming a triangle on each lobe and a ring around the perforation (Fig. 4/47-B). Three kinds of components were manufactured to form this bead.

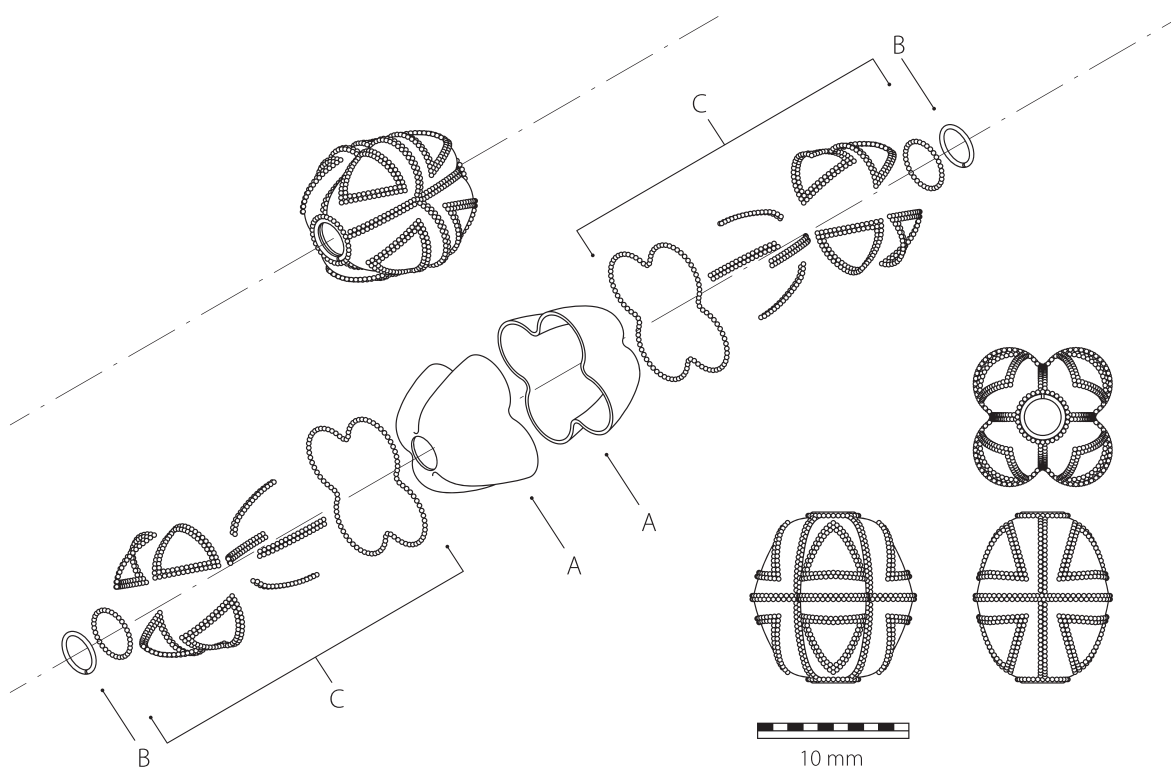

Fig. 4/47: Bead H25-2: exploded view of the bead showing the different components composing the bead: A - quadrilobed hemispheres; B - rings; C - granules (drawing G. Plítková).

Obr. 4/47: Perla H25-2: schématické znázornění jednotlivých komponent rozložené sestavy perly: A – čtyřlaločné hemisféry; B - kroužky; C - granule (kresba G. Plítková).

Bead H25-2		Dimensions [mm]
Total length		11.3
Total width		9.2
Granule (C)	\emptyset	0.3
Ring's wire (B)	\emptyset	0.4
Ring (B)	\emptyset	3.2
Hemisphere (A)	thickness	0.04 (44 μ m)

Table 62: Dimensions of the different components of the bead H25-2.

Tab. 62: Rozměry jednotlivých částí perly H25-2.

Condition of the bead, quality of the work

The bead is in a very poor condition (*Fig. 4/48 a*). It is extremely brittle because of intergranular corrosion attack, thinness of the metal sheet used to manufacture it, and past chemical treatment it went through. It is not complete. The loss of material is visible around the perforations. Some areas, granules in particular, are covered by a mixed layer of silver sulphides and chlorides (*Fig. 4/48d*). Newly formed silver sulphides were also observed under electron scanning microscopy (*Fig. 4/48c*).

The overall quality of the bead is excellent.

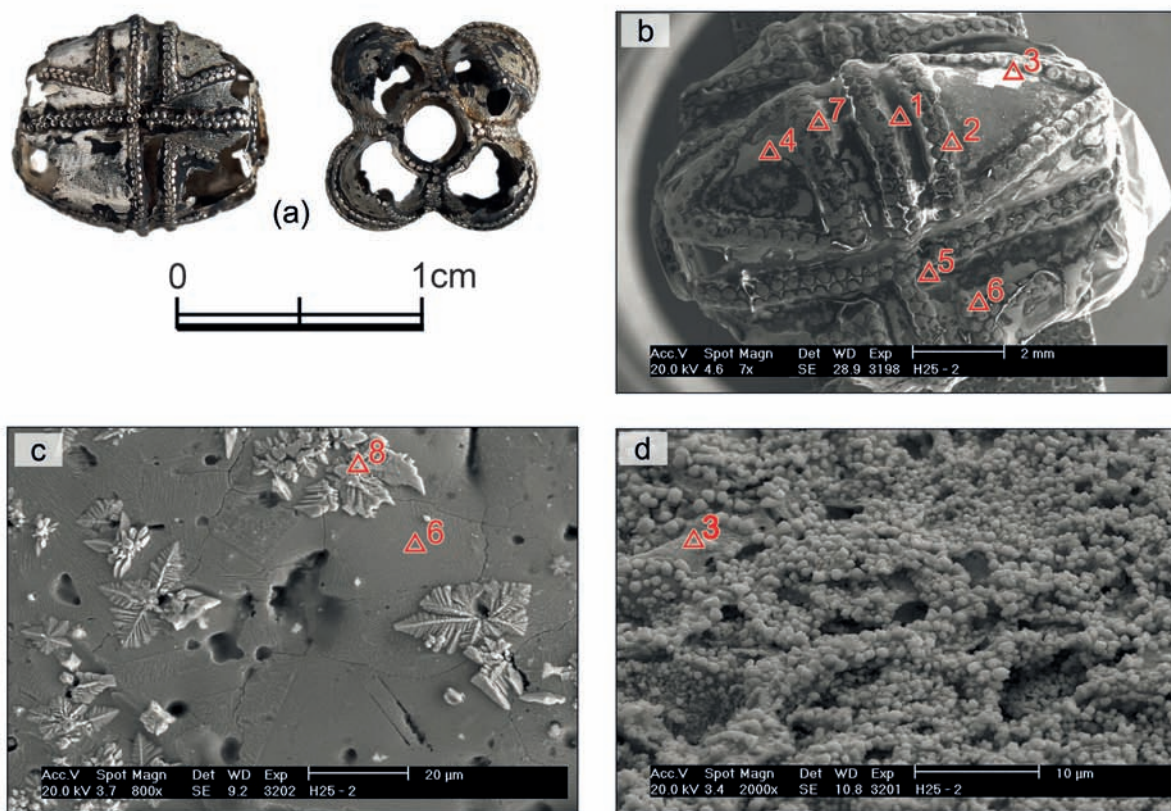

Fig. 4/48: Bead H25-2: a - general view of the bead (photo J. Sobek); b - analysed components, SEM micrograph (SE image, photo D. Janová); c - newly formed silver sulphide, SEM micrograph (SE image, photo D. Janová); d - layer of silver sulphide, SEM micrograph (SE image, photo D. Janová).

Obr. 4/48: Perla H25-2: a - celkový pohled na perlu (foto J. Sobek); b - mikrosnímek z rastrovacího elektronového mikroskopu (zobrazení SE) s vyznačením míst bodové mikroanalýzy jednotlivých komponent (snímek D. Janová); c - nově vzniklé krystaly sulfidu stříbrného, mikrosnímek z rastrovacího elektronového mikroskopu (zobrazení SE, snímek D. Janová); d - vrstva sulfidu stříbrného, mikrosnímek z rastrovacího elektronového mikroskopu (zobrazení SE, snímek D. Janová).

Scanning electron microscopy and microanalysis

SEM/EDX analyses performed directly on the artefacts as well as on a polished cross-section of an available fragment have shown that silver alloys with a small amount of copper (from 2.8 to 4.5 %) (Table 63) were used to manufacture the granules. The hemispheres were manufactured with silver copper alloy containing 5.8 % of copper. The bead was in a very poor condition, it was extremely brittle, overcleaned on some parts, and still covered by corrosion products on others. Therefore, results obtained from the surface (e. g. hemisphere) sometimes do not correspond with the original material which was revealed by analysis performed on the cross section. Analyses on the solder area on the cross section have detected only pure silver with silicium.

Components forming the bead H25-2	Chemical composition [Wt. %]			
	Ag	Cu	S	Si
Granule (C), point 1, clean surface	96.8	3.2	-	-
Granule (C), point 2, clean surface	95.5	4.5	-	-
Upper hemisphere (A), corroded, point 3	98.4	-	1.6	-
Lower hemisphere (A), corroded, point 4	93.8	-	6.2	-
Solder area between granules, point 5	93.5	5	1.5	-
Granule (C), point 6, clean surface	95.7	4.3	-	-
Solder area between granules corroded, point 7	93.4	-	6.6	-
Newly formed silver sulfides, point 8	90.1	-	9.9	-
Granule (C), cross section, point 9	97.2	2.3	-	-
Granule (C), cross section, point 10	96.1	3.9	-	-
Hemisphere (A), cross section, point 11	94.2	5.8	-	-
Solder area, cross section, point 12	98.5	-	-	1.5

Table 63: Chemical composition of the different element composing the bead H25-2.

Tab. 63: Chemické složení jednotlivých částí perly H25-2.

5.6. TRILOBED HEMISPHERE BEAD WITH GRANULATION WORK IN THE FORM OF MALTESE CROSSES (TYPE 6)

This type of bead was recovered from grave H16 which contained one of the wealthiest individuals of the “Lumbe Garden” cemetery. A young woman was buried there along with three of these beads (H16-16, H16-17, H16-18) which were probably part of a necklace holding, as well a highly decorated silver *kaptorga*. Eleven zoomorphic earrings and a pair of “two-layered” *gombiky* with glass cabochons were also part of the grave goods (*Frolík - Smetánka 2014*, p. 64-68). The beads are made of ternary Au-Ag-Cu alloy.

Description of the bead H16-18 (*Fig. 4/49*)

The bead is hollow. It is made of two thin sheets (0.1 µm in thickness) of gold alloy forming two three-lobed hemispheres (*Fig. 4/49-A*) soldered together and pierced in the middle (*Fig. 4/50a*). Each hemisphere's perforation is surrounded by rings (*Fig. 4/49-C*) of 6 mm in diameter and are made of a round and smooth wire of 0.9 mm in diameter. The sheets of the hemispheres overlap the ring around the perforations (*Fig. 4/50d*). A thin round wire (*Fig. 4/49-B*) of 0.2 mm in diameter is covering the joining area between the two hemispheres (*Fig. 4/50b, e*). The bead bears a rich decoration of granulation. Each hemisphere is divided in three registers delimited by a line of granules and decorated in its center by four triangles made of granules forming a cross ornament (*Fig. 4/50c*). A line of granules is displayed around the upper and bottom ring. The granulation decoration is made with granules (*Fig. 4/49-D*) of 0.2 to 0.6 mm in diameter. Four different kinds of components were manufactured to form the bead.

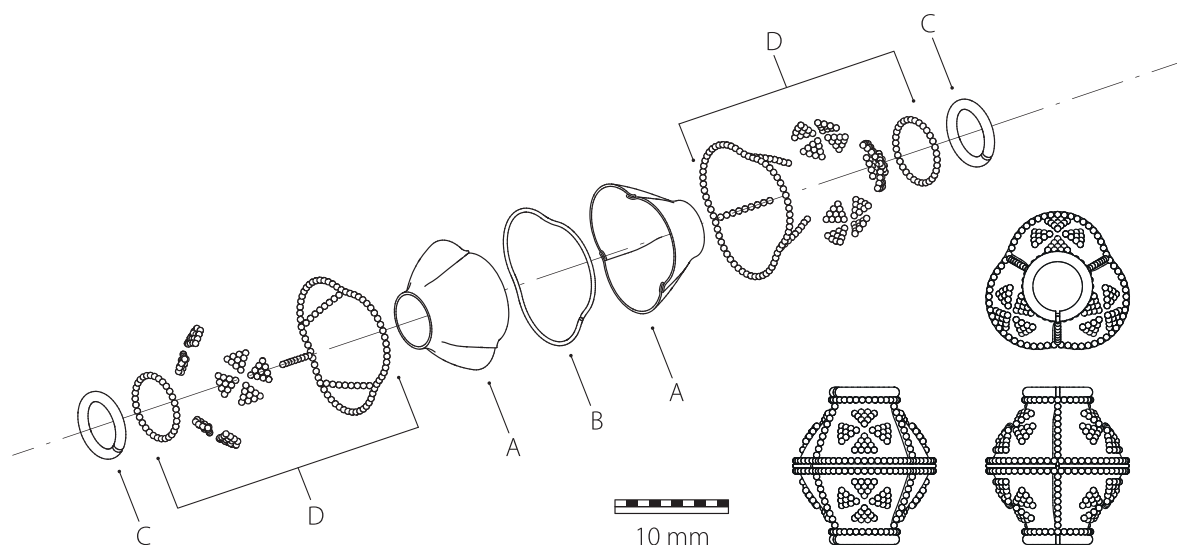

Fig. 4/49: Bead H16-18: exploded view showing the different components composing the bead: A - trilobed hemispheres; B - round wire; C - rings; D - granules (drawing G.Plítková).

Obr. 4/49: Perla H16-18: schématické znázornění jednotlivých komponent rozložené sestavy perly: A - třílaločné hemisféry; B - kruhový drát; C - kroužky; D - granule (kresba G. Plítková).

Bead H16-18		Dimensions [mm]
Max. diameter		12
Total length		13.5
Ring (C)	Ø	6
Wire (C)	Ø	0.9
Wire (B)	Ø	0.2
Granules (D)	Ø	0.2 to 0.6
Hemisphere (A)	thickness	0.1

Table 64: Dimensions of the bead H16-18 and its components.

Tab. 64: Rozměry jednotlivých částí perly H16-18.

Condition of the bead and quality of work

The bead is complete (Fig. 4/50a). It is slightly deformed by overburden during burial. It is also pierced, probably as a consequence of excavations. The bead surface was tarnished (Fig. 4/50b). Smearred solder around granulation work was observed under stereomicroscope (Fig. 4/50c).

The overall quality of the work is high.

Scanning electron microscopy and microanalysis

SEM/EDX analysis showed that gold-silver-copper alloys were used to manufacture all the components of the bead (Table 65). Wire (B) and granule (D) were manufactured with the same alloy

→ **Fig. 4/50:** Bead H16-18: a - general views of the bead (photo J. Sobek); b - detail of the round sectioned wire covering the joining area of the two half shells (photo E. Ottenwelter); c - detail of the granulated cross ornament (photo E. Ottenwelter); d - detail of the shell sheet overlapping the ring (photo E. Ottenwelter); e - detail of the joining area between the two hemispheres (photo E. Ottenwelter); f - analysed components, SEM micrograph (SE image, photo D. Janová); g - analysed ring, SEM micrograph (SE image, photo D. Janová).

→ **Obr. 4/50:** Perla H16-18: a - celkový pohled na perlu (foto J. Sobek); b - detail drátu kruhového průřezu, překrývající oblast spoje dvou hemisfér (foto E. Ottenwelter); c - detail granulace - křížový ornament (foto E. Ottenwelter); d - detail plechu pláště, překrývajícího kroužek (foto E. Ottenwelter); e - detail oblasti spoje mezi dvěma hemisférami (foto E. Ottenwelter); f - mikrosnímek z rastrovacího elektronového mikroskopu (zobrazení SE) s vyznačením míst bodové mikroanalýzy jednotlivých komponent (snímek D. Janová); g - mikrosnímek z rastrovacího elektronového mikroskopu (zobrazení SE) s vyznačením místa bodové mikroanalýzy kroužku (snímek D. Janová).



(a)

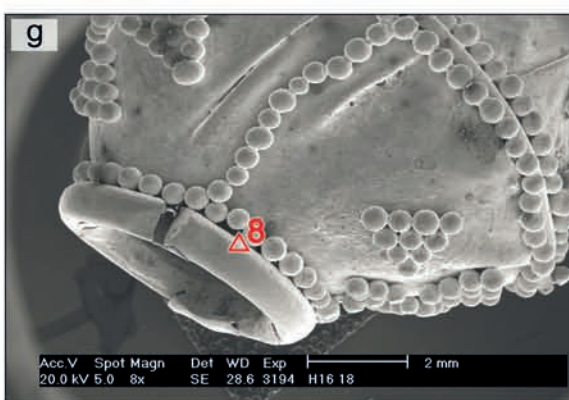
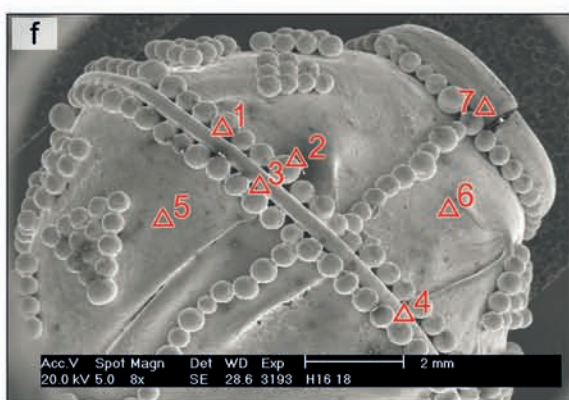
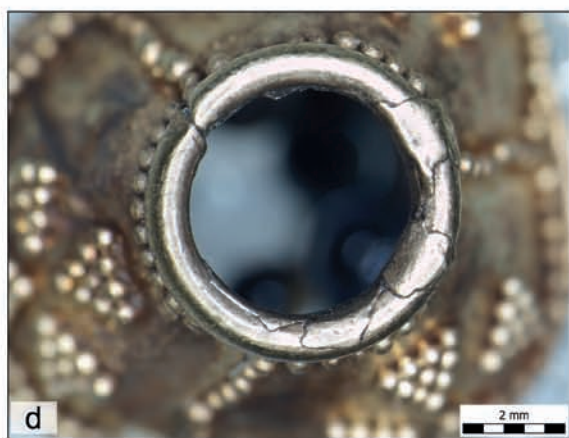
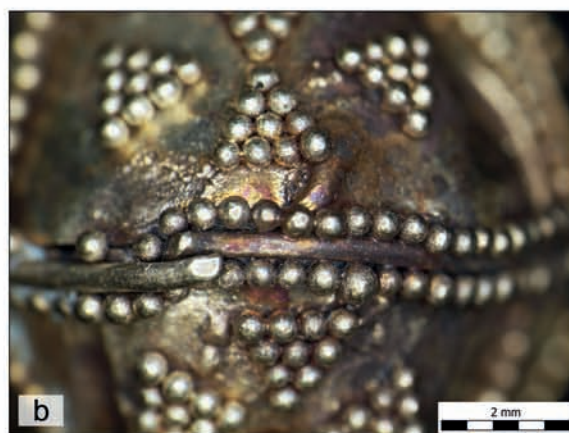

containing 50.6 % of gold, about 42 % of silver and 7.4 % of copper. The hemispheres (A) were manufactured with a ternary alloy of gold-silver and copper containing from 44.8 to 48.7 % of gold, 43.9 to 48.2 % of silver and about 7% of copper. Solder area exhibit a higher content of copper (point 3-4) which suggest that copper was used in the solder.

Components forming the bead H16-18	Chemical composition [Wt. %]		
	Au	Ag	Cu
Wire (B), point 1	50.6	41.4	8
Granule (D), point 2	50.6	42	7
Solder area between two granules, point 3	50.3	32.6	17.1
Solder area between two granules, point 4	48.3	34	17.7
Lower hemisphere (A), point 5	48.7	43.9	7.4
Upper hemisphere (A), point 6	44.8	48.2	7
Upper ring (C), point 7	48.3	46.4	5.3
Bottom ring (C), point 8	52.7	41.5	5.8

Table 65: Chemical composition of the different elements composing the bead H16-18.

Tab. 65: Chemické složení jednotlivých částí perly H16-18.

5.7. BEAD WITH APPLIED BOSSES AND FILIGREE DECORATION (TYPE 7)

This bead is the only specimen of this type (H53-18) in the “Lumbe Garden” cemetery. It was retrieved in the grave of a rich woman along with four ternary Au-Ag-Cu alloys earrings with globules, a silver *kaptorga*, two copper gilded *gombiky* with glass beads cabochons, and four silver earrings with globules (Frolík - Smetánka 2014, p. 64-68).

Description of the bead (Fig. 4/51)

The bead is constructed around a central sphere composed of two thin (0.1 mm in thickness) sheet hemispheres (13.3 mm in diameter) shaped from a blank disc embossed with a dapping tool, pierced and soldered together (see Barčáková in this volume). Three smaller, hollow hemispherical bosses of 5.8 mm in diameter decorate each big hemisphere forming the body of the bead. The bead bears a rich decoration of filigree made of two kinds of wires. The first type of wire is a single loosely-twisted strip of 0.8 mm in width (Fig. 4/51b). It is soldered on the bead at the joining area between the two main hemispheres. The second type of wire is a square-sectioned rod twisted as tightly as possible forming a round-sectioned wire of 0.5 mm in diameter (Fig. 4/51c). The second type of filigree wire forms rings around the decorative bosses as well as reverse “omega” shape ornaments (Fig. 4/51c) which are placed between the small decorative bosses and which also top each of them. Each per-

→ **Fig. 4/51:** Bead H53-18: a - general views of the bead (photo J. Sobek); b - detail of the different types of filigree (photo E. Ottenwelter); c - analysed components, SEM micrograph (BSE image, photo D. Janová); d - detail of the brittle boss surface with numerous intercrystalline fissures (photo E. Ottenwelter); e - heavily etched surface, SEM micrograph (BSE image, photo D. Janová); f - large branched intergranular crack (photo E. Ottenwelter); g - surface intercrystalline microfissures, SEM micrograph (BSE image, photo D. Janová); h - fracture showing severe intergranular corrosion, SEM micrograph (SE image, photo D. Janová).

→ **Obr. 4/51:** Perla H53-18: a - celkový pohled na perlu (foto J. Sobek); b - detail různých typů filigránové dekorace (foto E. Ottenwelter); c - mikrosnímek z rastrovacího elektronového mikroskopu (zobrazení BSE) s vyznačením míst bodové mikroanalýzy jednotlivých komponent (snímek D. Janová); d - detail křehkého povrchu pukličky s četnými interkrystalickými trhlinami (foto E. Ottenwelter); e - silně naleptaný povrch, mikrosnímek z rastrovacího elektronového mikroskopu (zobrazení BSE, snímek D. Janová); f - rozsáhlá rozvětvená interkrystalická trhlina (foto E. Ottenwelter); g - povrchové mikrotrhliny interkrystalického charakteru, mikrosnímek z rastrovacího elektronového mikroskopu (zobrazení BSE, snímek D. Janová); h - lomová fazeta, dokumentující rozsáhlé interkrystalické korozní napadení, mikrosnímek z rastrovacího elektronového mikroskopu (zobrazení SE, snímek D. Janová).

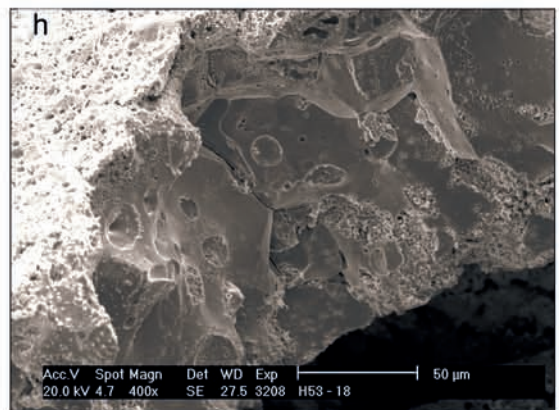
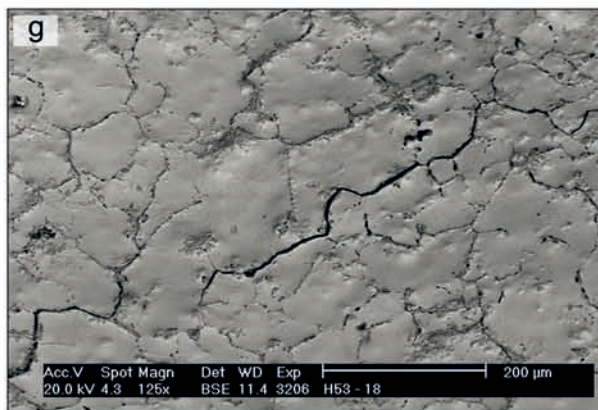
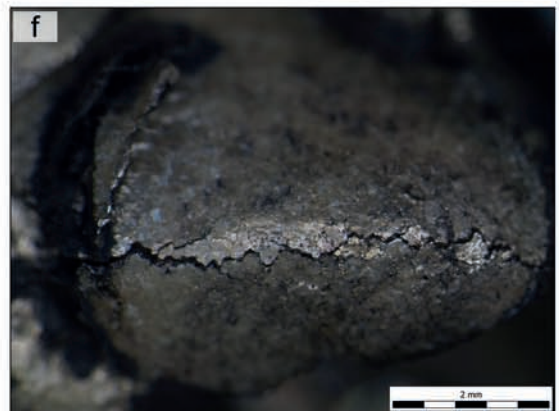
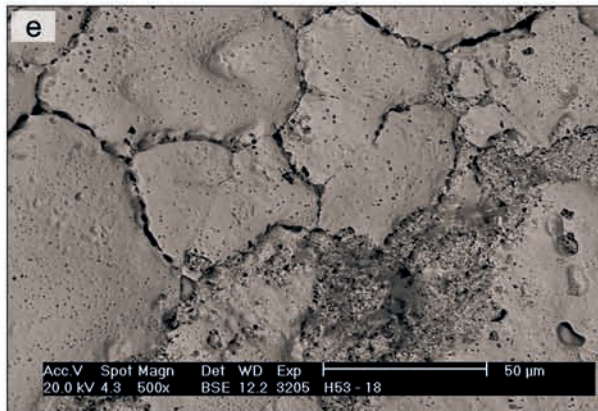
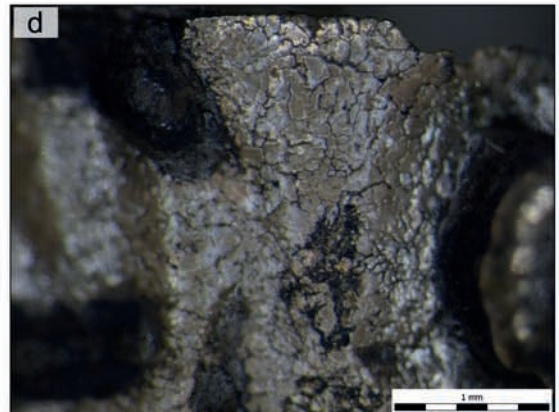
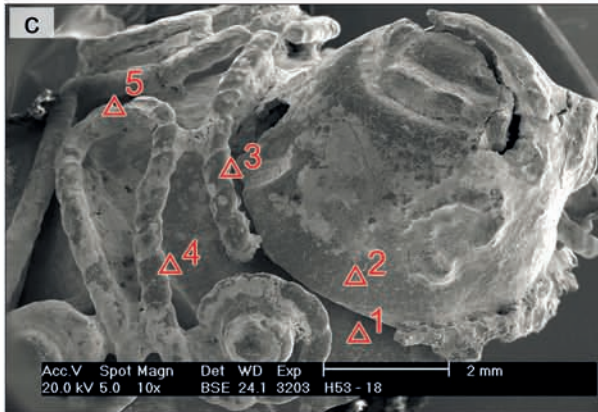
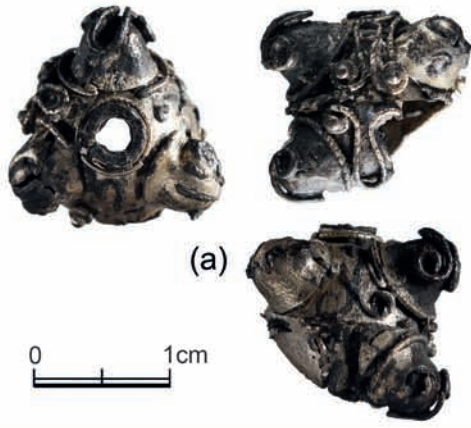

foration has a round-sectioned wire ring of 4.3 mm in diameter surrounded by a ring of filigree wire of the second type. Granules of 1 mm of diameter are sitting in the ends of the omega shape ornament (*Fig. 4/51b*) placed on the central hemispheres. Nine different kinds of components were manufactured to form this bead (hemisphere, applied boss, loosely twisted strip, big omega shape, small “omega” shape, small granule, small filigree ring, smooth ring around perforation, decorative ring around perforation).

Condition of the bead and quality of work

The condition of the bead is poor. It is incomplete (*Fig. 4/51a*). A third of it has disappeared. The body of the bead appears to be extremely brittle because of intergranular corrosion (*Fig. 4/51d, f, g, h*). Microcracks (*Fig. 4/51f, g*) and fractures (*Fig. 4/51h*) are visible. A lot of filigree decoration has been lost. Past chemical treatment by immersion in cyanides has considerably etched the surface (*Fig. 4/51e*). Cleaned surfaces mainly corresponding to the central hemisphere are heavily etched while the highly mineralized filigree wire has a surface composed of a mixture of silver sulphides and chlorides. It was not possible to clean the surface of this artefact.

The overall quality of work of the bead is high.

Bead H53-18		Dimensions [mm]
Central hemisphere	Ø	13.3
Central hemisphere	thickness	0.1
Applied boss	Ø	5.8
Granule	Ø	1
Strip, filigree, first type	width	0.8
Wire, filigree second type	Ø	0.4
Filigree ring around perforation	Ø	4.3
Ring around decorative bosses	Ø	7.4
Wire around perforation	Ø	1
Ring around perforation	Ø	4.3

Table 66: Dimensions of the different components of the bead H53-18.

Tab. 66: Rozměry jednotlivých částí perly H53-18.

Scanning electron microscopy and microanalysis

Results from SEM/EDX analysis showed that the same material was used to manufacture all the components forming the bead: almost pure silver with an average of 2.5 % of copper (Table 67). The analysis performed on the metallic core on a cross section from a fragment of filigree wire of the second type is in accordance with these results.

Components forming the bead H53-18	Chemical composition [Wt. %]			
	Ag	Cu	S	Cl
Big hemisphere, point 1	97.4	2.6	-	-
Applied boss, point 2	97.2	2.8	-	-
Twisted wire, point 3	96.9	2	1.1	-
Twisted wire, point 4	97.8	2.2	-	-
Corrosion products on twisted wire, point 5	88.9	-	1.3	9.8
Metallic core, cross section from fragment of filigree type 2	97.2	2.8	-	-

Table 67: Chemical composition of the different elements composing the bead H53-18.

Tab. 67: Chemické složení jednotlivých částí perly H53-18.

5.8. BEAD WITH APPLIED BOSSES AND GRANULATION DECORATION (TYPE 8)

This type of bead also represents one specimen in the “Lumbe Garden” cemetery. It was found in grave H116A with two silver grape earrings. This grave belonged to a woman (*Frolík - Smetánka 2014*, p. 190-191). The bead is, unfortunately, in a very bad state of preservation. It was squashed and broken into several fragments. It is, therefore, impossible to precisely describe its profile and dimensions.

It is also not possible to precisely identify the material it was made of because it is completely covered by corrosion products and entirely mineralized. We only can be sure it was made with quite pure silver because no corrosion products of copper are present on the surface nor were any detected in analysis.

Description of the bead H116A-3 (*Fig. 4/52*)

The bead seems to be hemispherical or oval. It is composed of two hemispheres of approximately 26.4 mm in diameter. The top and bottom hemispheres are pierced and topped by a ring of 6 mm in diameter made of a round section wire of 0.7 mm in diameter. The joining area between the hemispheres is covered by a round wire of 0.5 mm in diameter surrounded by a line of granules above and underneath it. Each hemisphere is decorated by small, hollow, hemispherical bosses framed by circles of granules between which lines of triangles made of granules are displayed. The size of the granules is 0.5 mm in diameter. Five different kinds of components had to be manufactured to form this bead.

Bead H116A-3		Dimensions [mm]
Central hemisphere	Ø	26.4 ?
Central hemisphere	thickness	n. d
Applied boss	Ø	5.5
Granule	Ø	0.5
Wire, filigree	Ø	0.5
Filigree ring around perforation	Ø	4.3
Wire around perforation	Ø	0.7
Ring around perforation	Ø	6

Table 68: Dimensions of the different components of the bead H116A-3.

Tab. 68: Rozměry jednotlivých částí perly H116A-3.

Condition of the bead and quality of work.

The bead is completely deformed due to overburden (*Fig 4/52*). It was probably manufactured with a very thin sheet of silver as were other beads. It was completely squashed, probably just after burial. It is entirely mineralized and covered by a layer of silver chlorides and sulphides. No attempt of cleaning was done on the object prior to analyses because of its advanced state of mineralization.

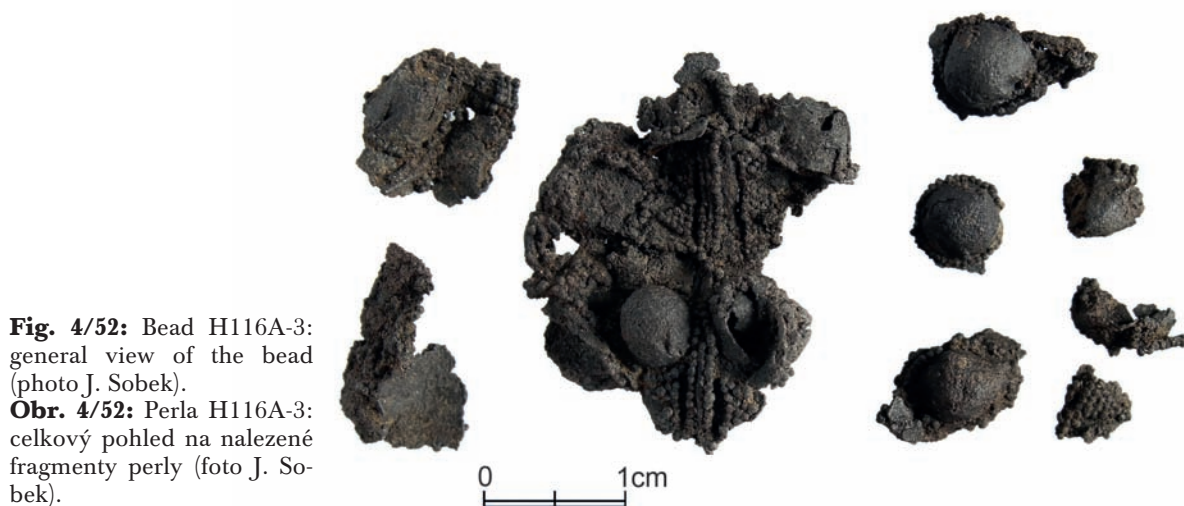

Fig. 4/52: Bead H116A-3: general view of the bead (photo J. Sobek).

Obr. 4/52: Perla H116A-3: celkový pohled na nalezené fragmenty perly (foto J. Sobek).

Scanning electron microscopy and microanalysis

Scanning electron microscopy performed on a small fragment of the bead crushed into powder has revealed a highly corroded silver alloy (table 69). No traces of copper were detected.

Bead H116A-3	Chemical composition [Wt. %]				
	Ag	O	Al	Si	Cl
Powdered fragment of the bead	46.9	38	1.7	2	11.3

Table 69: Chemical composition of the bead H116A-3.

Tab. 69: Chemické složení perly H116-3.

6. KAPTORGA (AMULET CONTAINER)

Kaptorgy are small amulet containers which were part of necklaces. Most of them are constructed of two elements: a box and a cover made out of a folded metallic sheet and have a trapezoidal shape. Types vary based on the techniques of decoration including granulation, filigree, applied bosses, glass cabochons, and incision. Most of them were suspended on metallic chains. Five specimens of *kaptorga* were present in the “Lumbe Garden” cemetery (Fig. 4/53).

6.1. KAPTORGA WITH RICH GRANULATION WORK (TYPE 1)

This *kaptorga* was found in grave H82 where a woman was buried. A metallic necklace on which was threaded the following *kaptorga*, as well as a smaller one and five metallic beads in open filigree work. Eleven silver pseudoglobular earrings were also part of the grave goods (Frolík - Smetánka 2014, p. 146-151).

Description of the *kaptorga* H82-14 (Fig. 4/54)

The *kaptorga* has a trapezoidal shape of 26.5 mm in height, with a width of 30.6 mm at the base, and 29.2 mm on the top of the cover. The box is about 4.6 mm deep and the cover is 6.5 mm. It is composed of two elements: a box made from a folded sheet (Fig. 4/54-A) on which



Fig. 4/53: Summarizing table of the different types of *kaptorga* present in the set of the “Lumbe garden” necropolis: type 1 - *kaptorga* with rich granulation work (H82-14): Ag-Cu alloy, 5 different kinds of components; type 2 - *kaptorga* with rich filigree decoration and embedded coloured glass table (H82-15): Ag-Cu alloy, glass, 12 different kinds of components; type 3 - *kaptorga* with rich filigree, granulation, applied bosses and glass cabochons decoration (H16-19a): Ag-Cu alloy, 10 different kinds of components; type 4 - *kaptorga* with engraved and stamped decoration (H117-14): Ag-Cu alloy, 5 different kinds of components; type 5 - *kaptorga* with a “tear-shaped” section and zoomorphic decoration (H53-10): Ag-Cu alloy, 10 different kinds of components.

Obř. 4/53: Souhrnný přehled různých typů analyzovaných kaptorg, přítomných v souboru nálezů z pohřebiště v Lumbeho zahradě: typ 1 - kaptorga s bohatou granulací (H82-14): slitina Ag-Cu, složená z pěti různých druhů komponent; typ 2 - kaptorga s bohatou filigránovou dekorací, zdobená zasazenými tabulkami z barevného skla (H82-15): slitina Ag-Cu, sklo, složená z dvanácti různých druhů komponent; typ 3 - kaptorga s bohatou filigránovou a granulovanou dekorací, zdobená skleněnými vložkami (H16-19a): slitina Ag-Cu, slitiny, složená z deseti různých druhů komponent; typ 4 - kaptorga s rytou a raženou dekorací (H117-14): slitina Ag-Cu, složená z pěti různých druhů komponent; typ 5 - kaptorga se “slzovitým” bočním průřezem a zoomorfní dekorací (H53-10): slitina Ag-Cu, složená z deseti různých druhů komponent.

a trapezoidal sheet was soldered (Fig. 4/54-B) onto the back, and a cover made of a rectangular, folded sheet (Fig. 4/54-C) soldered onto the back and topped with a rectangular sheet (Fig. 4/54-D, see Barčáková in this volume). Both are perforated. The chain of the necklace on which it was suspended passes through these holes and holds the *kaptorga* closed. The *kaptorga* (box and cover) is decorated with rich granulation work (Fig. 4/54-E) forming rows of triangles, rosettes, and lines of granules on the front, sides, and bottom of the *kaptorga*.

Each decorated part has its border underlined by a row of granules (Fig. 4/54-E₁-E₆). The front side of the box (Fig. 4/54-E₁) is decorated with a first line of rhombi comprising four granules above

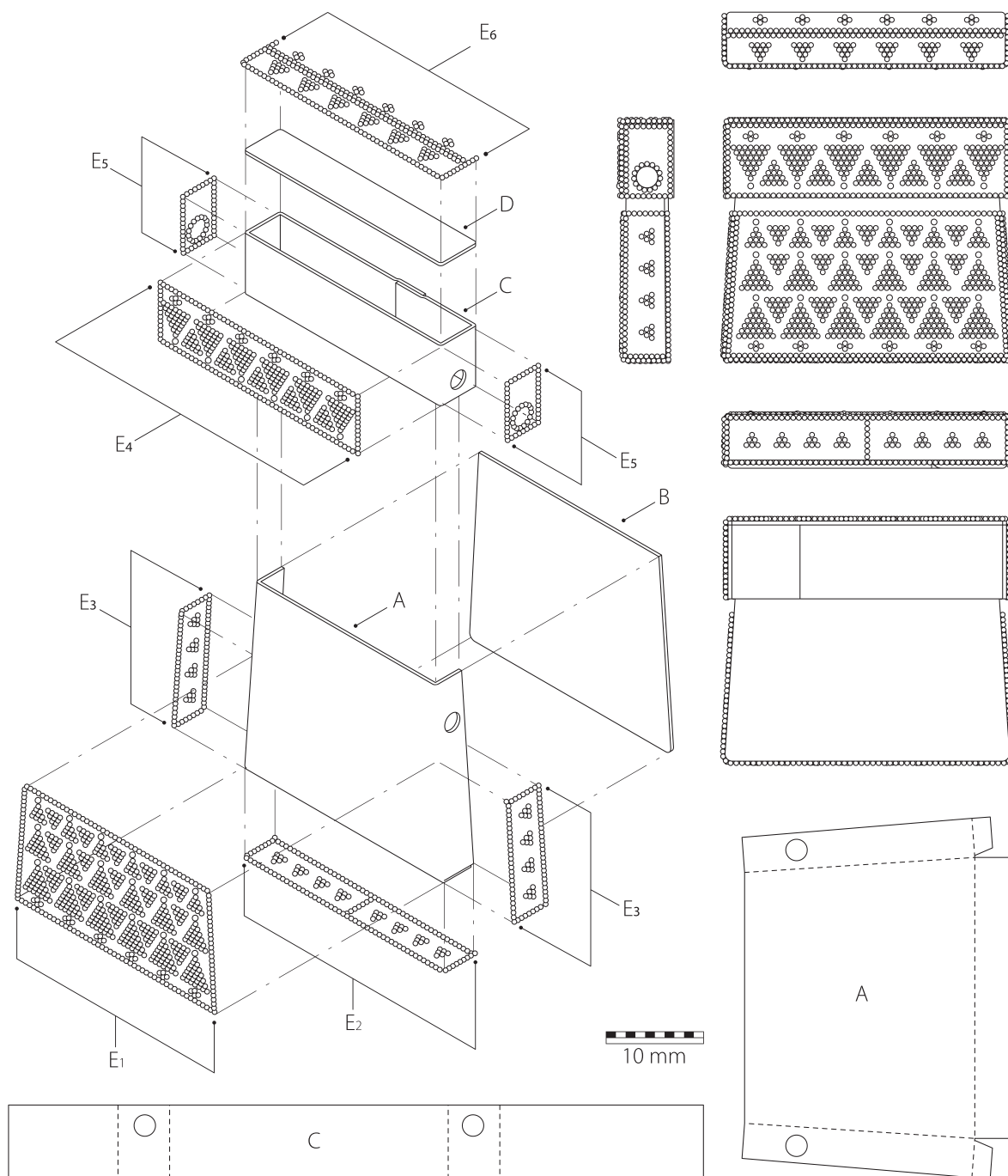
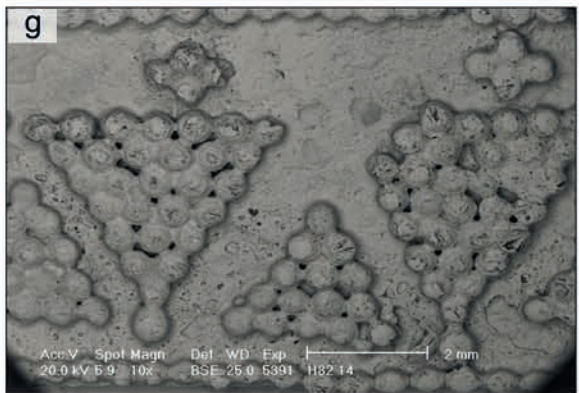
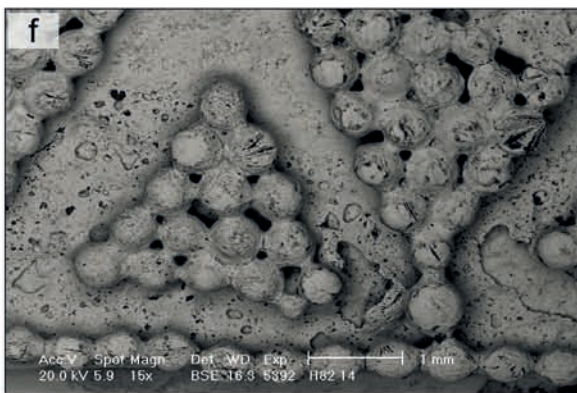
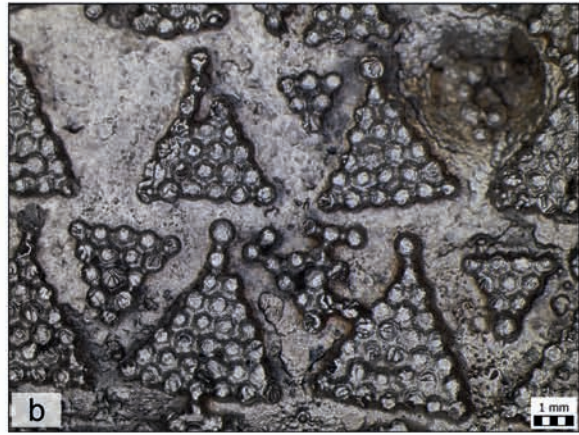

Fig. 4/54: *Kaptorga* H82-14: exploded view: A - box, front sheet; B - box, back sheet; C - cover side sheet; D - cover, top sheet; E - granules (drawing G. Plítková).

Obr. 4/54: *Kaptorga* H82-14: schématické znázornění jednotlivých komponent rozložené sestavy *kaptorgy*: A - schránka, přední plech; B - schránka, zadní plech; C - boční plech víčka; D - horní plech víčka; E - granule (kresba G. Plítková).



<i>Kaptorga</i> H82-14		Dimensions [mm]
Height		26.5
Box, front sheet (A)	max. width	30.6
Cover, main sheet (C)	min. width	29.2
Cover (C)	depht	6.5
Box (A)	depht	4.6
Cover (C)	height	8.6
Box (A)	height	24
Granules (E)	\emptyset	0.5
Big granules	\emptyset	0.7
Sheet box (A)	thickness	0.2

Table 70: Dimensions of the *kaptorga* H82-14 and its components.

Tab. 70: Rozměry jednotlivých částí kaptorgy H82-14.

which three rows of triangles of decreasing size are placed, each topped by a bigger granule, and between which smaller reverse triangles are placed. The motif on the box of the first row of triangles is repeated on the cover but upside down to give a mirror effect. The sides of the box (Fig. 4/54- E_3) are decorated by a row of four small triangles with three granules at their base. The bottom (Fig. 4/54- E_2) of the box bears a row of identical triangles as on the sides. A double line of granules divides the bottom into two symmetrical parts. The top of the cover (Fig. 4/54- E_4) is decorated with a line of triangles, a double line of granules, and a line of rhombi. The back sheet of the box and the cover are not decorated except for a line of granules following the overlap of the folded sheet of the cover. A line of granule is surrounding the perforations of the cover (Fig. 4/54- E_5).

On the whole, five different kinds of components were used to manufacture the *kaptorga*.

Condition of *kaptorga* H82-14, quality of work

The *kaptorga* is in a poor state of preservation. It is not complete. The back sheet of the box is only partially preserved, as is the bottom (Fig. 4/55a). Fragments are also missing from the cover, in particular on the back side at the corner and sides. Rows of granules have fallen off, most visibly from the front-right side of the cover. The *kaptorga* is mechanically deformed and extremely brittle due to severe intergranular corrosion. The sheets of metal used to manufacture the *kaptorga* were only 0.2 mm thick which explains its poor state of preservation. The *kaptorga* was overcleaned by past treatment with alkaline cyanides (Fig. 4/55f, g). Most of the original corrosion products covering the surface were dissolved by cyanides, although some silver chlorides were still present at the bottom corners of the *kaptorga* (Fig. 4/55d). The *kaptorga* was also covered by a thin layer of tarnishing.

A modern sheet of silver was placed inside the *kaptorga* during past restoration in order to strengthen the material (Fig. 4/55a - back side). A new sheet of metal was also soldered to the upper side of the *kaptorga*.

Defects in the manufacture of the *kaptorga* are noticeable, in particular in the arrangement of the granules on the front of the box (Fig. 4/55b, c). Variable sizes and compositions of granules shows that the craftman used available, already prepared granules which he had at his disposal.

The surface shows traces of wear along the decorative rows of granules running on the bottom edge of the *kaptorga* (Fig. 4/55e). It is possible that a glass pencil was used to abrade corrosion products in past restoration treatment.

← **Fig. 4/55:** *Kaptorga* H82-14: a - *kaptorga*'s front and reverse sides (photo J. Sobek); b - detail of the granulation work on the box front (photo E. Ottenwelter); c - detail of the granulated triangle ornament topped by a bigger granule (photo E. Ottenwelter); d - remains of silver chloride in the lower corner of the *kaptorga* (photo. E.Ottenwelter); e - worn, abraded granules (photo E. Ottenwelter); f - overcleaned surface by previous chemical treatment, SEM micrograph (BSE image, photo D. Janová); g - granulation work on the cover's front, SEM micrograph (BSE image, photo D. Janová).

← **Obr. 4/55:** Kaptorga H82-14: a – přední a zadní strana kaptorgy (foto J. Sobek); b - detail granulace na přední straně schránky (foto E. Ottenwelter); c - detail granulované dekorace ve tvaru trojúhelníku s velkou granulí na vrcholu (foto E. Ottenwelter); d – zbytky chloridu stříbrného ve spodním rohu kaptorgy (foto. E.Ottenwelter); e - odřená granule (foto E. Ottenwelter); f - poškození povrchu při předchozím příliš intenzivním chemickém čištění, mikrosnímek z rastrovacího elektronového mikroskopu (zobrazení BSE, snímek D. Janová); g – granulace na přední straně víka kaptorgy, mikrosnímek z rastrovacího elektronového mikroskopu (zobrazení BSE, snímek D. Janová);

The irregular size of the granules used and defects in their arrangement (*Fig. 4/55d*) show a lack of quality in the manufacture of this artefact. However, the thinness of the sheet and the amount of granulation work denotes an item requiring great skill to produce.

Scanning electron microscopy and microanalysis

Electron micro-probe analysis showed that the same binary Ag-Cu alloy containing approximately 95 % of silver and 5 % of copper was used to manufacture the sheets forming the box and the cover of the *kaptorga* (Table 71). Different binary Ag-Cu alloys with lower contents of copper were used to manufacture the granules. Solder areas analyses have detected only pure silver on surface analyses, but a higher content of copper was detected between granules of the cross section (see *Kolářová – Děd – Ottenwelter* in this volume).

Components forming the <i>kaptorga</i> H82-14	Chemical composition [Wt. %]	
	Ag	Cu
Front sheet box (A)	95	5
Back sheet box (B)	94.9	5.1
Top sheet cover (D), cross section	95	5
Main sheet cover (C)	95.7	4.3
Small granule, cross section	97.7	2.3
Small granule, cross section	99	0.9
Big granule	98.1	1.9
Solder area, cross section between core sheet and granule	92.3	7.7
Solder area between granules	100	-

Table 71: Chemical composition of the different elements composing the *kaptorga* H82-14.

Tab. 71: Chemické složení jednotlivých částí *kaptorgy* H82-14.

6.2. KAPTORGA WITH RICH FILIGREE DECORATION AND GLASS CABOCHONS (H82-15) (TYPE 2)

This *kaptorga* was found in grave H82 and was part of the necklace H82-13 (*Frolik – Smetánka 2014*, p. 146-151).

Description of *kaptorga* H82-15

The *kaptorga* has a trapezoidal shape (*Fig. 4/56a*) of 15.3 mm in height and a width of 17 mm at the base and 15 mm on the top of the cover. The box is about 5 mm deep while the cover is about 6 mm deep. The box and the cover of the *kaptorga* are constructed in the same way as previous *kaptorga* (H82-14) but are much smaller.

→ **Fig. 4/56:** *Kaptorga* H82-15: a - *kaptorga*'s front and reverse sides (photo J. Sobek); b - detail of filigree work on the cover top (photo E. Ottenwelter); c - detail of the embedded coloured glass table in its bezel (photo E. Ottenwelter); d - filigree work on the bottom of the *kaptorga* (photo E. Ottenwelter); e - analysed filigree work from the cover's top, SEM micrograph (BSE image, photo D. Janová); f - analysed cover top plate, SEM micrograph (BSE image, photo D. Janová); g - analysed solder area between two wires forming the loose braid on the cover's top, SEM micrograph (BSE image, photo D. Janová); h - numerous branched intercrystalline cracks observed on the back plate, SEM micrograph (BSE image, photo D. Janová).

→ **Obr. 4/56:** *Kaptorga* H82-15: a - přední a zadní strana *kaptorgy* (foto J. Sobek); b - detail filigránu na horní straně víčka (foto E. Ottenwelter); c - detail tabulky barevného skla v obrubě (foto E. Ottenwelter); d - filigránová dekorace na dně *kaptorgy* (foto E. Ottenwelter); e - horní strana víčka s vyznačenými místy bodové mikroanalýzy různých prvků filigránové dekorace, mikrosnímek z rastrovacího elektronového mikroskopu (zobrazení BSE, snímek D. Janová); f - vyznačené místo bodové mikroanalýzy plechu víčka na jeho horní straně, mikrosnímek z rastrovacího elektronového mikroskopu (zobrazení BSE, snímek D. Janová); g - vyznačené místo bodové mikroanalýzy oblasti pájky mezi dvěma dráty, tvořícími pletenec na horní straně víčka, mikrosnímek z rastrovacího elektronového mikroskopu (zobrazení BSE, snímek D. Janová); h - četné rozvětvené interkrystalické trhliny na zadní stěně schránky *kaptorgy*, mikrosnímek z rastrovacího elektronového mikroskopu (zobrazení BSE, snímek D. Janová).

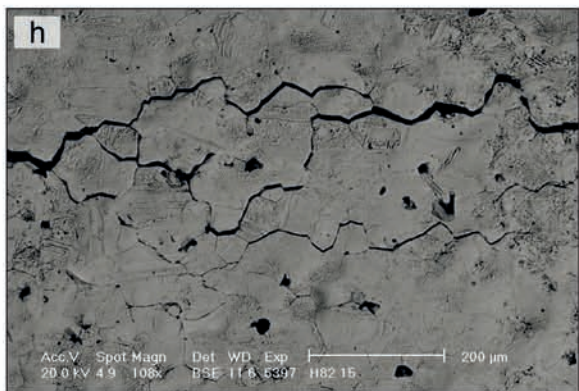
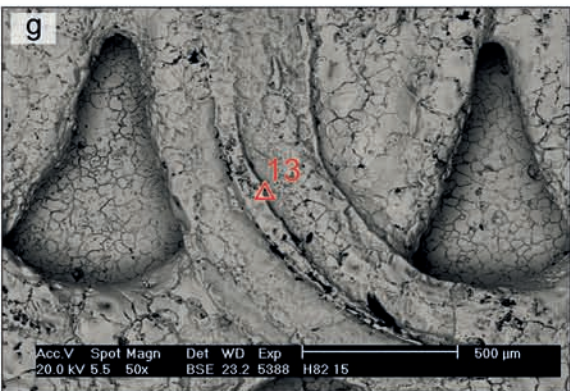
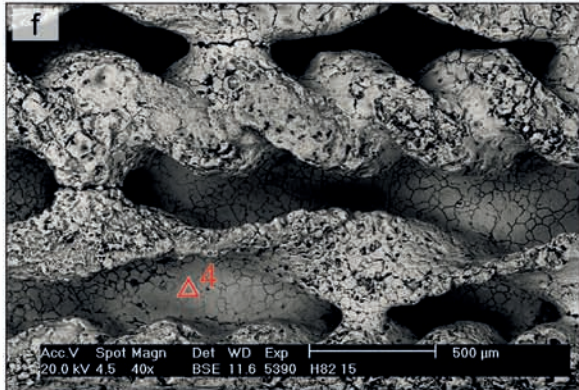
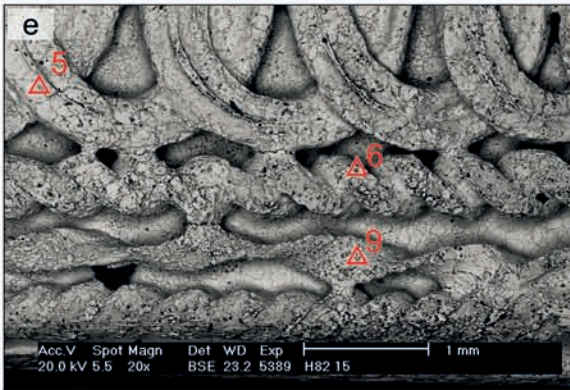
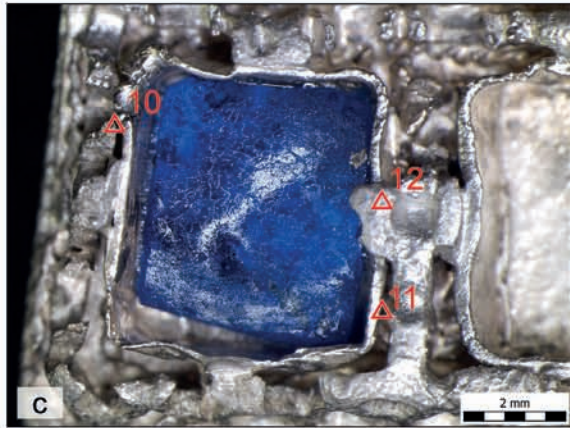
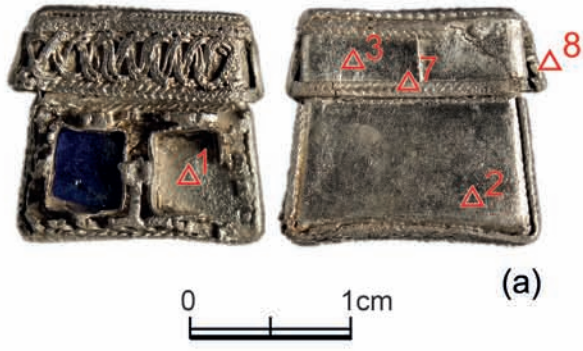

It is composed of two elements: a box made from a folded sheet of 0.2 mm in thickness on which a trapezoidal sheet was soldered onto the back, and a cover made of a rectangular, folded sheet soldered onto the back and topped with a rectangular sheet. Both are perforated. The chain of the necklace on which it was suspended passes through these holes and holds the *kaptorga* closed.

The *kaptorga* is decorated with rich filigree decoration (Fig. 4/56b, d, f): wires of 0.2 mm in diameter forming loose braids, braids formed with two wires twisted in opposite direction and placed next to each other, thin strips of metal either loosely twisted or forming corrugated strips (Fig. 4/56d). It is also decorated with blue, rectangular, buffed, top glass cabochons inserted into rectangular bezels constructed with thin strips of metal (Fig. 4/56c).

The *kaptorga* is decorated on the front, sides, top, and bottom. The back side (Fig. 4/56a) remains plain except for a braid-like ornament running along the top and bottom edges of the cover. Two rings made with a wire of 0.8 mm in diameter are soldered around the holes on the cover's sides. The *kaptorga* is made with twelve different kinds of components.

Condition of the *kaptorga* and quality of the work

The *kaptorga* is almost complete, though part of the filigree decoration, the right bezel, and its contents are missing (Fig. 4/56a). The *kaptorga* was covered by remains of horn silver and a newly formed layer of tarnishing. It is brittle and the surface is heavily etched (Fig. 4/56g, h). Microspheres of glass were found in recesses of the bezel which proved that the *kaptorga* was sandblasted in the past as well.

The overall quality of this artefact is excellent.

Scanning electron microscopy and microanalysis

Electron micro analysis showed that the front and back sheet of the box as well as the top plate of the cover were manufactured from the same binary Ag-Cu alloy with a copper content of around 5.2 % (Table 73). The silver alloy used to manufacture the lower part of the cover contains less copper. It was made with a similar silver alloy as the twisted wire and ring around the perforation, the loose braid, and the strip forming the bezel containing about 3.5 to 4 % of copper. The copper content in the corrugated strip and the bezel claws is lower (around 1.5 %). Analyses made on the solder areas did not detect a significant increase of copper content.

<i>Kaptorga</i> H82-15		Dimensions [mm]
Total	height	15.3
Box	max. width	17
Box	depht	5
Box	height	n. d
Box sheet	thickness	0.2
Cover	min. width	15
Cover	depht	6
Cover	height	6
Sheet box	thickness	n. d
Wire (braid)	Ø	0.2
Wire (twisted)	Ø	0.2
Wire (ring)	Ø	0.8
Loosely twisted strip	width	0.3
Corrugated strip	width	0.6
Corrugated strip	thickness	0.4
Strip (bezel)	width	4
Strip (bezel)	thickness	0.4
Strip (bezel claws)	width	1.4
Glass cabochon	lenght	5

Table 72: Dimensions of the *kaptorga* H82-15 and its components.

Tab. 72: Rozměry jednotlivých částí *kaptorgy* H82-15.

Components forming <i>kaptorga</i> H82-15	Chemical composition [Wt. %]	
	Ag	Cu
Front sheet box, point 1	94.9	5.1
back sheet box, point 2	94.6	5.4
Sheet cover, point 3	96.2	3.8
Top sheet cover, point 4	94.8	5.2
Wire (loose braid), point 5	96.1	3.9
Wire (twisted), point 6	96.4	3.6
Wire (twofold braid), cover, point 7	100	-
Wire (ring around perforation), point 8	96.5	3.5
Strip (loosely twisted), point 9	95.8	4.2
Strip (corrugated), point 10	98.4	1.6
Strip (bezel), point 11	95.8	4.2
Strip (bezel claws), point 12	98.6	1.4
Solder area between the wires forming the loose braid, point 13	94.3	5.7

Table 73: Chemical composition of the different elements composing the *kaptorga* H82-15

Tab. 73: Chemické složení jednotlivých částí *kaptorgy* H82-15.

6.3. KAPTORGA WITH RICH FILIGREE, GRANULATION DECORATION, APPLIED BOSSES AND GLASS CABOCHONS (H16-19A) (TYPE 3)

This *kaptorga* was found in grave H16 where a young woman was buried. Grave goods also included thirteen ternary Au-Ag-Cu alloys zoomorphic earrings, a pair of gold “two-layered” *gombik* with glass cabochons, three metallic beads in ternary Au-Ag-Cu alloys, and a knife (*Frolík - Smetánka 2014*, p. 64-68).

Description of *kaptorga* H16-19a and associated metallic chain

The *kaptorga* has a trapezoidal shape of almost 40 mm at the base and 35 mm at the cover. It is about 32 mm high. It is composed of two elements: a box and its cover (*Fig. 4/58a*). The box is made of a folded sheet (*Fig. 4/57-A*) on which was soldered a rectangular sheet (*Fig. 4/57-B*). The cover is made of a rectangular folded sheet (*Fig. 4/57-C*) soldered on the back and topped by a rectangular sheet (*Fig. 4/57-D*). The sheets of metal used to manufacture this *kaptorga* are three time thicker (0.6 mm) than the sheets used to manufacture previous *kaptorgy*. The box and the cover are perforated. The perforations on the cover are strengthened by a coiled strip of metal of 0.4 mm width (*Fig. 4/57-F*) surrounded by a ring of granules (*Fig. 4/57-G*).

The *kaptorga* is decorated on the front by granulated applied bosses (*Fig. 4/57-H*), originally, probably glass cabochons (*Fig. 4/57-J*) in bezels (*Fig. 4/57-I*) (see *Barčáková* in this volume), and granulation work (*Fig. 4/57-G*). The reverse side was left plain. Bezels (*Fig. 4/57-I*) are placed on the corners of the cover and in the center of the lower part as well as in the lower corners. They are now empty. They were probably filled with glass cabochons (*Fig. 4/57-J*). Unfortunately, none of them have survived. The sides, top, and bottom plates of the *kaptorga* are decorated by three parallel, loose braids (*Fig. 4/57-E*) formed by three double wires of 0.2 mm in diameter (*Fig. 4/58a*). Part of the chain which was holding the *kaptorga* was preserved in the cover (*Fig. 4/57d*). It is a chain consisting of figure-eights folded in half exactly the same type as the *kaptorga*'s chain from grave H82. The wire used is also thicker (0.6 mm in diameter). The granulation work (*Fig. 4/57-G*) was done with granules of 0.5 mm in diameter displayed in triangles and rings around the bezels and bosses as well as in double lines forming crosses on the bosses (*Fig. 4/58c*). A double line of granules underlies the

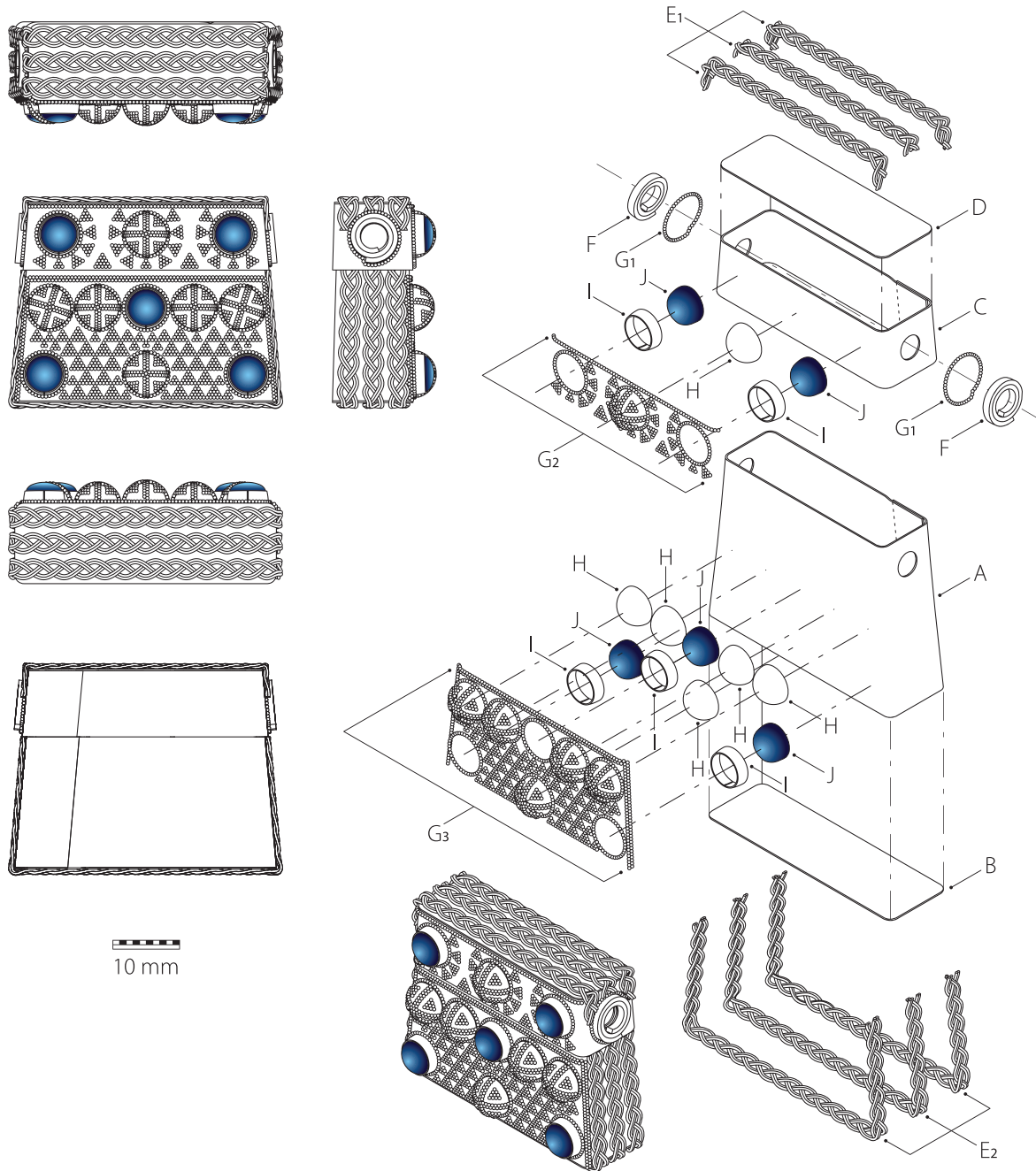

Fig. 4/57: *Kaptorga* H16-19a: exploded view: A - main sheet composing the box; B - bottom sheet of the box; C - main sheet composing the cover; D - top sheet of the cover; E₁ - braid ornaments on the cover; E₂ - braid ornaments on the box; F - coiled strips; G₁ - rings of granules; G₂ - granules on the cover's front; G₃ - granulation work on the box's front; H - applied bosses; I - bezels (drawing G. Plítková).

Obr. 4/57: *Kaptorga* H16-19a: schématické znázornění jednotlivých komponent rozložené sestavy kaptorgy: A - hlavní plech, z něhož je zhotovena schránka; B - plech dna schránky; C - hlavní plech, z něhož je zhotoveno víčko; D - horní plech víčka; E₁ - pletencové dekorace víčka; E₂ - pletencové dekorace schránky; F - svinuté pásky; G - kroužky granulí; H - pukličky; I - obruby (kresba G. Plítková).

sides of the decorated area of the box. A line of granules also runs along the top side of the cover. Granulated triangles (*Fig. 4/57-G₂*) are placed in a radiant way around the bezels and the central applied bosses. They fill the empty surface area between the applied bosses on the box but without symmetry (*Fig. 4/58b*). The *kaptorga* was made with presumably ten different components (including the presently missing glass cabochons).

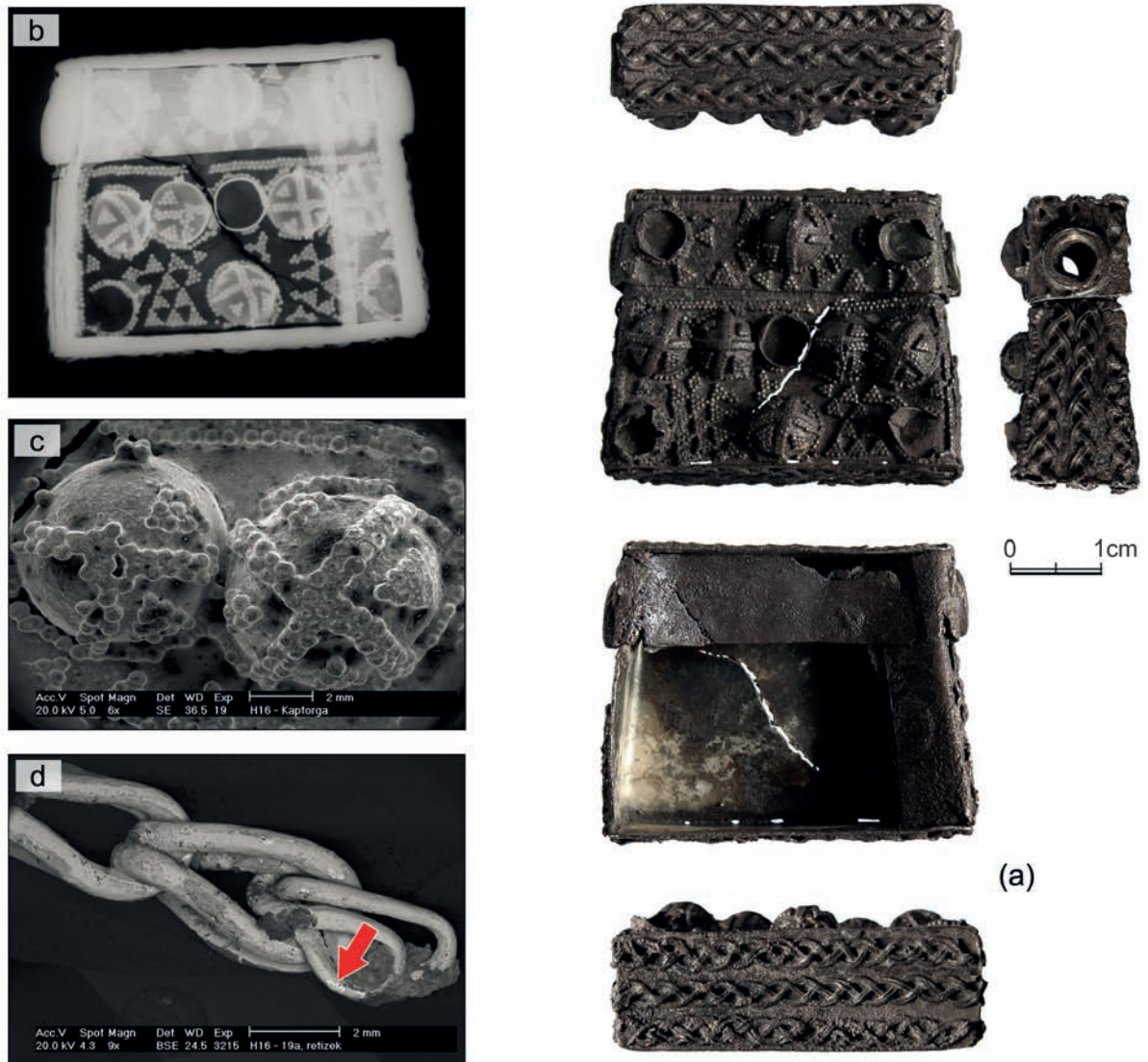

Fig. 4/58: *Kaptorga* H16-19a: a - *kaptorga*'s general views (photo J. Sobek); b - *kaptorga*'s X-radiograph (D. Perlík); c - detail of the granulation work on the applied bosses, SEM micrograph (SE image, photo D. Janová); d - remains of gilding layer on the chain, SEM M micrograph (BSE image, photo D. Janová).

Obr. 4/58: *Kaptorga* H16-19a: a - celkové pohledy na *kaptorgu* z různých stran (foto J. Sobek); b - rentgenový snímek *kaptorgy* (D. Perlík); c - detail granulce na pukličkách, mikrosnímek z rastrovacího elektronového mikroskopu (zobrazení SE, snímek D. Janová); d - zbytky zlaté vrstvy na řetízku, mikrosnímek z rastrovacího elektronového mikroskopu (zobrazení BSE, snímek D. Janová).

H16-19a		Dimensions [mm]
Total length at the base (B)		39.6
Width of the base (B)		13.9
Height		31.9
Length of the cover (C)		35.6
Bosses (H)	Ø	6.5
Bezel (I)	Ø	5.6
Bezel	thickness of the sheet	0.1
Granule (G)	Ø	0.5
Sheet (A)	thickness	0.6
Wire from the braid (E)	Ø	0.2
Coiled strip (F)	width	0.4
Wire, chain	Ø	0.6

Table 74: Dimensions of the *kaptorga* H16-19a and its components.

Tab. 74: Rozměry jednotlivých částí kaptorgy H16-19a.

Condition of the *kaptorga* and quality of the work

The *kaptorga* is not complete. The back sheet of the box is almost completely missing (*Fig. 4/58a*). The *kaptorga's* surface is covered by silver corrosion products - mainly chlorides and sulphides.

Although the thickness of the metallic sheet employed denotes an expensive item in term of material, the realization of the granulation work is rather messy. The granulated triangles are not displayed in a very organized way on the front side.

Scanning electron microscopy and microanalysis

Analyses performed on the cleaned surfaces of each component of the *kaptorga* showed that silver alloys with about 4 % of copper was used to manufactured the different components of the *kaptorga* (Table 75). The alloy used to manufacture the chain contains 1 % less of copper while a little higher content of copper was detected in the bosses. The fragment of the chain which was preserved in the *kaptorga* had remains of gilding on its surface. Mercury was detected. We can therefore conclude it was gilded by fire-gilding.

Components forming the <i>kaptorga</i> H16-19a	Chemical composition [Wt. %]				
	Ag	Cu	Hg	Cl	Au
Sheet (A), point 1	95	5	-	-	-
Sheet, (A), clean surface	96.2	3.8	-	-	-
Granule (G), point 4	99.5	-	-	0.5	-
Boss (H), point 5	95.3	4.7	-	-	-
Sheet cover (C), point 6	95.9	4.1	-	-	-
Granule (G ₂), cover, point 7	96.3	3.7	-	-	-
Wire, braid (E ₂) point 8	96	4	-	-	-
Chain, point 13, clean surface	96.9	3.1	-	-	-
Chain, gilding, point 14	20.6	2.1	4.1	-	73.2

Table 75: Chemical composition of the different element composing the *kaptorga* H16-19a.

Tab. 75: Chemické složení jednotlivých částí kaptorgy H16-19a a řetízku.

6.4. KAPTORGA WITH ENGRAVED AND STAMPED DECORATION (H117-14) (TYPE 4)

This *kaptorga* was found in grave H117 with other valuable materials including a necklace with glass, amber, and semi-precious beads, a knife, and five silver, S-shaped temple rings (*Frolík - Smetánka 2014*, p. 191-194).

Description of the *kaptorga* H117-14 (Fig. 4/59)

The *kaptorga* is in a very poor state of preservation. Only 30 % of the original *kaptorga* is preserved. The archaeological profile is not preserved, however it is possible to state that it was a trapezoidal box with a cover. The front sheet is the best preserved, even though its lower part is missing. It is decorated by engraved or chased zoomorphic motifs recalling celtic dragons. The cover bears a stamped, interlaced decoration.

<i>Kaptorga</i> H117-14		Dimensions [mm]
Height		n. d
Box	max. width	n. d
Cover	min. width	23
Cover	depht	0.7
Box	depht	0.7
Cover	height	10
Box	height	n. d
Sheet (Cover)	thickness	0.1
Ring´s wire	Ø	1.2

Table 76: Dimensions of the *kaptorga* H117-14 and its components.

Tab. 76: Rozměry kaptorgy jednotlivých částí H117-14.

Components forming the <i>kaptorga</i> H117-14	Chemical composition [Wt. %]	
	Ag	Cu
Sheet box, surface	98.5	1.5
Sheet cover, surface	94.4	5.6
Sheet cover, cross-section	93.3	6.7
Ring	93.6	6.4
Solder area under the ring	97.8	2.2

Table 77: Chemical composition of the different elements composing the *kaptorga* H117-14.

Tab. 77: Chemické složení jednotlivých částí kaptorgy H117-14.



Fig. 4/59: *Kaptorga* H117-14: general view of fragmented *kaptorga* (photo. J. Sobek).

Obr. 4/59: Kaptorga H117-14: celkový pohled na fragmenty kaptorgy (foto J. Sobek).



Fig. 4/60: *Kaptorga* H53-10: a - *kaptorga*'s general view (photo J. Sobek); b - detail of the zoomorphic ornament (photo E. Ottenwelter); c - detail of the filigree work on the bottom of the *kaptorga* (photo E. Ottenwelter); d - detail of the heads of the zoomorphic ornament on the top of the *kaptorga* (photo E. Ottenwelter); e - detail of the filigree decoration on the *kaptorga*'s side (photo E. Ottenwelter); f - intergranular corrosion (photo E. Ottenwelter).

Obr. 4/60: Kaptorga H53-10: a - celkový pohled na kaptorgu (foto J. Sobek); b - detail zoomorfní dekorace (foto E. Ottenwelter); c - detail filigránové výzdoby na dně schránky kaptorgy (foto E. Ottenwelter); d - detail hlaviček zoomorfní dekorace na horní straně kaptorgy (foto E. Ottenwelter); e - detail filigránové výzdoby na boku kaptorgy (foto E. Ottenwelter); f - interkrystalické korozní napadení na povrchu pláště kaptorgy (foto E. Ottenwelter).

The construction of the *kaptorga* is the same as *kaptorga* H82-14. The box and the cover were perforated. A ring made with a round-sectioned wire of 1.2 mm in diameter flattened on one side was soldered around the holes of the cover. The *kaptorga* was made with five different kinds of components. The thickness of the used metal sheet is very thin (0.1 mm).

Condition of the *kaptorga*, quality of work

The remaining fragments of the *kaptorga* are extremely brittle because of intergranular corrosion and thinness of the metal sheet. Furthermore, the artefact has been weakened by past treatment in aqueous alkaline cyanides. As a result, the surface is heavily etched.

The chased decoration is of rather poor quality.

Scanning electron microscopy and microanalysis

Electron microprobe analysis performed on the surface of different components and a polished cross-section from the cover showed that the cover and the ring were manufactured with a silver alloy containing approximately 6 % of copper while analyses performed on the box evidenced silver with a lower content of copper (1.5 %) (Table 77). It is interesting to note that the quality and technology of decoration on the cover and the box also differs. The cover was made with a purer silver and the decoration is of better quality than the cover which was made with a more debased silver. Analysis performed on solder area on the ring did not evidence a higher content of copper.

6.5. KAPTORGA WITH A “TEAR-SHAPED” SECTION AND ZOOMORPHIC DECORATION H53-10 (TYPE 5)

This *kaptorga* was found in grave H53 where a woman was buried. Grave goods also included eight globular earrings in silver, ternary Au-Ag-Cu alloys and gilded silver, a pair of gilded copper *gom-biky* with glass cabochons, three silver beads, a knife and three glass, and semi-precious stone beads (Frolík - Smetánka 2014, p. 107-111).

Description of the *kaptorga* H53-10 (Fig. 4/60)

This *kaptorga* differs a lot from the previous types. The back side is not preserved but we can deduce from the preserved part that the central unit was a rectangular sheet of 0.2 mm in thickness forming a “tear-shaped” section trapezoidal empty container of approximately 36 mm in width on the base and 30 mm in width on the top. The end of the sheets overlap on the internal side on the top of the

<i>Kaptorga</i> H53-10	Dimensions [mm]
Approx. total width at the base	36
Max. depth of the base	9
Height	21
Sheet of the <i>kaptorga</i> body thickness	0.2
Twisted wire	0.4
Wire from the twisted wire	Ø 0.2
Wire on top of the <i>kaptorga</i>	Ø 0.4

Table 78: Dimensions of the *kaptorga* H53-10 and its components.

Tab. 78: Rozměry jednotlivých částí *kaptorgy* H53-10.

<i>Kaptorga</i> H53-10 and chain H53-9	Chemical composition [Wt. %]	
	Ag	Cu
Sheet, <i>kaptorga</i> 's body, cross-section	97.8	2.2
Link from the chain	94.8	5.2

Table 79: Chemical composition of the *kaptorga* H53-10 main body and chain H53-9.

Tab. 79: Chemické složení těla *kaptorgy* H53-10 a řetízku H53-9.

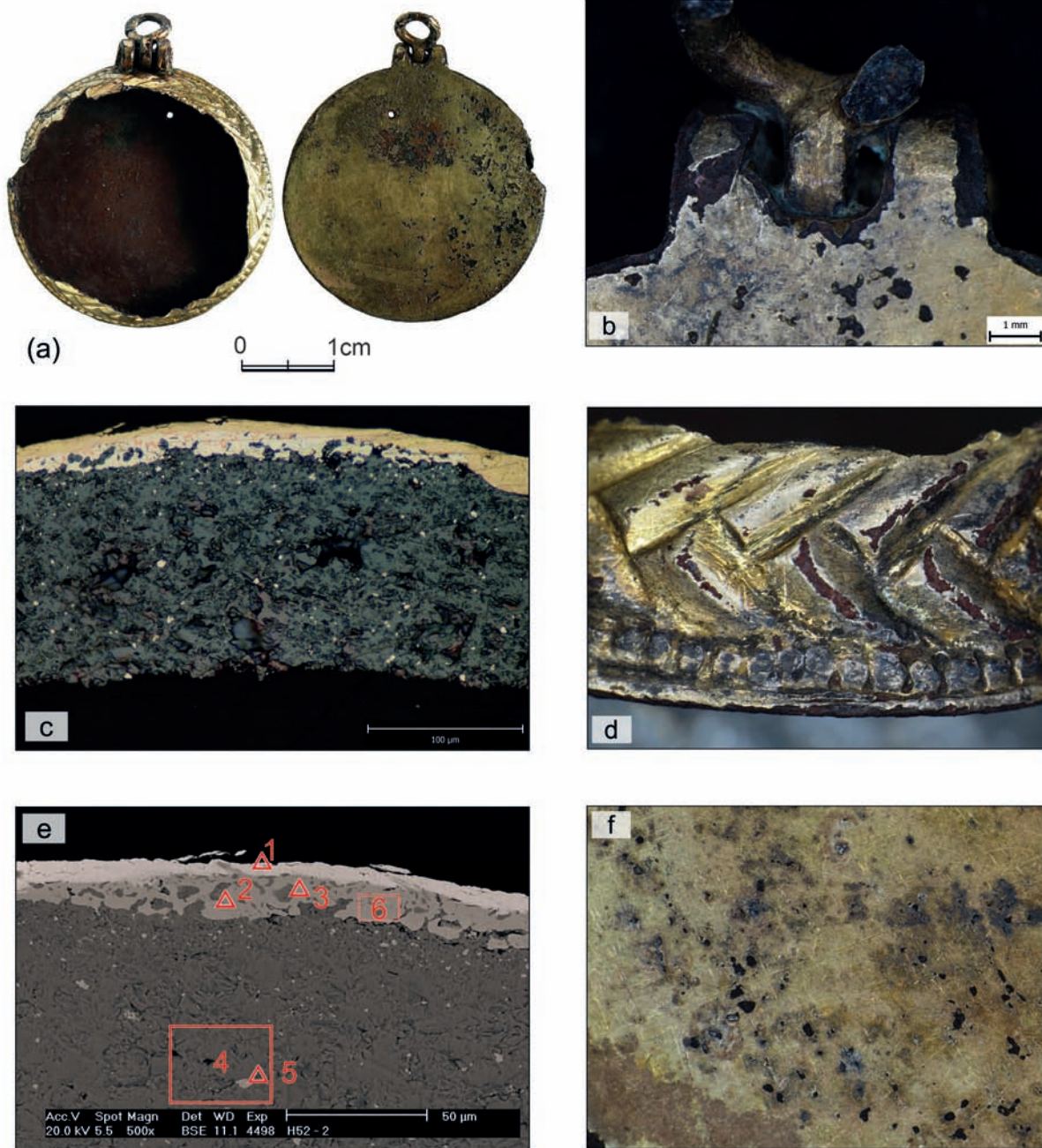

Fig. 4/61: Locket H52-2: a - front and reverse views (photo J. Sobek); b - detail of the suspension system (photo E. Ottenwelter); c - optical microscopy documentation of polished unetched cross section of the locket (photo E. Ottenwelter); d - detail of the worn gilding layer and silvery areas (photo E. Ottenwelter); e - polished unetched cross-section of the locket, SEM micrograph (BSE image, photo D. Janová); f - pitted gilding layer on the back of the locket (photo E. Ottenwelter).

Obr. 4/61: Medailónek H52-2: a - pohled na přední a zadní stranu medailónku (foto J. Sobek); b - detail závěsného systému (foto E. Ottenwelter); c - příčný metalografický výbrus stěny pláště medailónku (snímek z optického mikroskopu E. Ottenwelter); d - detail sedřené zlaté vrstvy a oblasti stříbřitého vzhledu (foto E. Ottenwelter); e - příčný nenaleptaný výbrus stěny pláště medailónku, mikrosnímek z rastrovacího elektronového mikroskopu (zobrazení BSE, snímek D. Janová); f - důlkové poškození zlaté vrstvy na zadní straně medailónku (photo E. Ottenwelter).

kaptorga and form a little loop which holds the folded sheet in position. Two “tear-shaped” sheets were soldered on the side (Fig. 4/60e). The *kaptorga* is decorated on the front side by four identical, zoomorphic ornaments (Fig. 4/60a, b) made with two “tear-shaped” shells soldered together. They are decorated with filigree work made with twisted double wires of 0.2 mm in diameter. The two shells composing the body of the zoomorphic ornament are also linked mechanically by a strip of silver of 1.4 mm in width threaded through holes pierced in the head with curled ends forming the ears of the animal (Fig. 4/60a, b, d) in a very similar way as in the zoomorphic earring from grave H16. The *kaptorga*'s top is decorated by a corrugated filigree (Fig. 4/60d) made with a round sectioned wire of 0.4 mm in diameter. The lower part also holds a complex decoration of filigree work made with interlaced, twisted double wires (Fig. 4/60c). The top and bottom of the *kaptorga* are round.

The *kaptorga* hangs on a multiple complex loop-in-loop chains (H53-9) (see Barčáková in this volume). The *kaptorga* was manufactured from ten kinds of components.

Condition of the *kaptorga*, quality of work

The *kaptorga* is in a very poor condition. The back sheet is almost completely missing. It is, furthermore, extremely brittle because of severe intergranular corrosion (Fig. 4/60f). Remains of copper and silver corrosion products covering the limit of the original surface are still present on the bottom of the *kaptorga*.

It is a very high quality work.

Scanning electron microscopy and microanalysis

Considering the state of preservation of the *kaptorga*, it was not possible to unvarnish this object to proceed to an SEM/EDX analysis of all the elements composing it. Analyses were, therefore, performed only on the cross-sections of an available fragment from the body of the *kaptorga* and on a fragment from the chain. They showed that almost pure silver with 2 % of copper was used to manufacture the body of the *kaptorga*, while a silver alloy containing more copper (5 %) was used to manufacture the chain (Table 79).

7. LOCKET

A pair of identical lockets were found in grave H52 where a two-year-old child was buried along with a knife, a ceramic, and a gilded copper alloy temple ring with an eyelet (Frolík - Smetánka 2014, p. 105-106).

Description of locket H52-2 (Fig. 4/61)

The locket is composed of five components joined together. A circular sheet of 28.5 mm in diameter and 0.4 mm in thickness with two appendices of rectangular section bended to form circular rings, a two components suspension loop, a rivet and a chased sheet forming the bezel. The suspension loop (Fig. 4/61a, b) is composed of a ring on which a smaller ring identical to the two rings formed by the appendices was soldered. A rivet is inserted through the three loops. It is slightly burred over at each end for permanent fastening of the suspension loop to the suspension fitting of the base sheet. An embossed thin sheet of 0.2 mm thick is soldered to the lower sheet to form a bezel. It bears

Locket H52-2		Dimensions [mm]
Locket	Ø	28.5
Suspension loop fitting	width	5.9
Upper loop	Ø	5
Loop wire	Ø	1.1
Thickness of the bottom sheet		0.4
Thickness of the upper sheet		0.2

Table 80: Dimensions of the locket H52-2 and its components.

Tab. 80: Rozměry jednotlivých částí medailónku H52-2.

a decoration of a braid between two granule-like rows (*Fig. 4/61d*). The bottom sheet is pierced (*Fig. 61a*). The hole is centred in locket H52-1 but it is on the upper corner in locket H52-2. Two hypotheses can explain the presence of these holes: If we suppose that the locket was an empty pendant with a complete embossed hemisphere soldered on the base, a hole would have been necessary to allow gases to be evacuated when soldering the hemisphere to the base sheet. The embossed sheet being incomplete, we can make the hypothesis that it was, in fact, a whole hemisphere. Without this hole, soldering such big closed element would not have been possible. The second hypothesis is that the embossed sheet is only a bezel in which a cabochon was inserted. Holes, in that case, would have helped to fix the cabochon.

Condition of the locket, quality of work

The condition of the locket is rather poor. The object is physically degraded and it was broken into several fragments. The upper embossed sheet is not complete. The bead that was probably filling the locket is missing. The bulk metal is completely mineralized (*Fig. 4/61c*). The gilding layer has worn away in many areas, in particular on the suspension loop as well as the edges of the locket (*Fig. 4/61d*). The remaining gilding layer is tarnished and pitted (*Fig. 4/61b, d, f*).

The overall quality of the work is high.

Scanning electron microscopy and microanalysis

Analyses were performed on the bottom sheet of the locket and on the cross-section of an available fragment from the soldered area between the lower part of the locket and the embossed sheet. Analyses presented here were performed on the polished unetched cross-section (*Fig. 4/61c, e*).

Components forming the locket H52-2	Chemical composition [Wt. %]			
	Au	Ag	Cu	Hg
Gilding layer, cross section, point 1	73.5	3.7	2.3	20.6
Solder area, white area cross section, point 2	-	91.1	8.9	-
Red particle in solder area, cross section, point 3	3	9	88	-
Corroded matrix, cross section area 4	-	2.3	97.7	-
White particle in corroded matrix, cross-section point 5	-	95	5	-
Solder area, cross-section, area 6	-	80.6	19.4	-

Table 81: Chemical composition of the cross section of a fragment of the locket H52-2.

Tab. 81: Chemické složení v místě příčného řezu fragmentem medailónku H52-2.

The base metal used to manufacture the lower part of the locket is almost pure copper with a small amount of silver (Table 81). The base metal being almost completely mineralized, it is impossible to state the exact percentage of silver present in the alloy, but it is, nevertheless, clearly present in all the mass of the bulk metal as small white particle (*Fig. 4/61c*). Solder used to join the bottom sheet and the embossed sheet is a hard solder composed of mainly silver and about 20 % of copper (point 6) (*Fig. 4/61e*). Observation under stereomicroscope showed the presence or tarnishing on the gilding layer and area where the gilding layer has worn away and where a silver-like plating was observed (*Fig. 4/61b, d*). Yet, the metallography of available fragment did not evidence a continuous layer of silver everywhere under the gilding layer (*Fig. 4/61c*). Still, we cannot exclude the hypothesis that the object was initially silver plated and then gilded. It is much easier to gild silver than copper because mercury in copper has a much lower solid solubility than mercury in silver.

Therefore the wetting of copper or copper alloy surface is more difficult than on a silver surface (Antheuser 1997, p. 58). Moreover, a first silver plating would have played a role of an additional physical barrier to avoid corrosion of the less noble bulk metal.

The external and visible part of the locket was gilded by fire-gilding. The amalgam contains a little bit of silver which can also explain why the gilding layer is tarnished.

8. JINGLE BELLS

Jingle bells are clothing ornaments. They have a hollow body with two perpendicular, narrow slots on the lower part and have a metallic pellet inside them which makes the jingle bells chime when the pellet is striking against its internal walls. On the whole, five jingle bells were recovered in the “Lumbe’s garden” cemetery. All of them were found in the graves of very young children (2-3 years old). The three nicest specimens were all found in grave H78 (Frolík - Smetánka 2014, p. 138-139). Three of them were made of bronze and were cast using the lost wax technique. The two others were made of pure copper and were manufactured by cold working and soldering with a silver-copper hard solder. Three of them were fire-gilded. Two jingle bells manufactured in different techniques were investigated by scanning electron analyses and are presented below.

8.1. DESCRIPTION OF THE JINGLE BELL H78-2 (Fig. 4/62)

The jingle bell has a spherical shape (15.5 mm in diameter) and a spherical suspension loop (Fig. 4/62a). The lower part has two slots forming four triangular petals. A metallic pellet of 5 mm in diameter is enclosed inside it. The lower part is decorated with two parallel lines (Fig. 4/62a). Petals are also decorated by grooves forming triangles (Fig. 4/62b).

This jingle bell was cast using the lost-wax method. Basically, it consists of constructing a model of wax and forming a mold over the outside of the cast. The wax is then drained by heating the entire mold, which is left with a hollow space formerly occupied by wax. Into this space, the molten metal is poured until it fills the void completely. After cooling, the mold is destroyed and the casting is finished with tools, if finishing is necessary (Untracht 1968, p. 338). The first and finest clay was used to cover the model in order to achieve optimal definition. This was followed by coarser grades of clay that have been mixed with a refractory material such as sand or straw to make the clay more porous and allow the escape of gases formed during the heating of the mold. The mold was then left dry. The wax model was removed from the mold using low heat without damaging the mold and the molten metal was cast. The mold required a pouring gate for the admission of the molten metal and some vents leading outward from the mold cavity to allow the release of gases formed during the casting. To finish the casting, attached vent projections and the pouring gate were removed mechanically. The metallic pellet was probably inserted into a refractory material inside the wax model. The jingle bell was fire-gilded. Its weight is 5.5 grams.

Jingle Bell H78-2		Dimensions [mm]
Jingle bell	Ø	15.5
Jingle bell	thickness of the walls	1.5
Jingle bell	total height	21
Suspension loop	Ø	8.3
Loop´s perforation	Ø	2
Suspension loop	thickness	2.4
Metallic pellet	Ø	5

Table 82: Dimensions of the jingle bell H78-2 and its components.

Tab. 82: Rozměry jednotlivých částí rolničky H78-2.

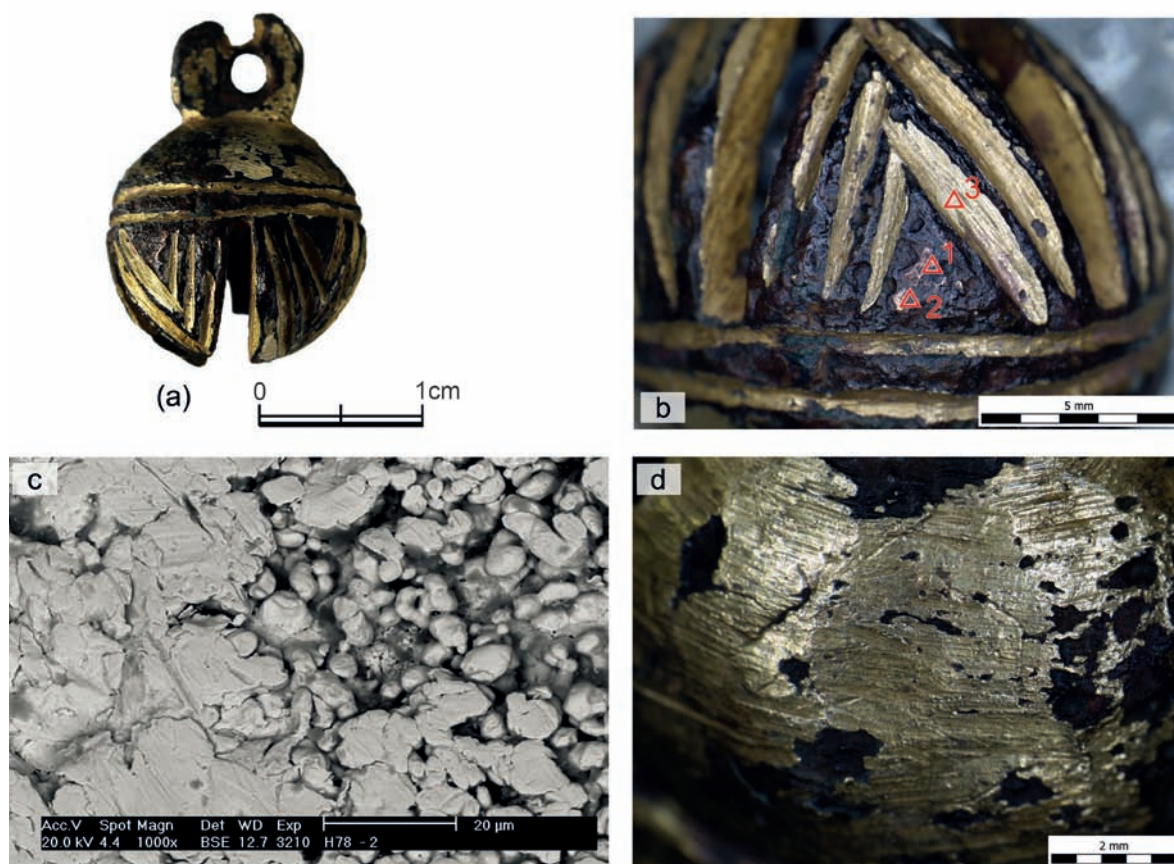

Fig. 4/62: Jingle bell H78-2: a - general view (photo J. Sobek); b - analysed points (photo E. Ottenwelter); c - partly burnished and unburnished gilding layer, SEM micrograph (BSE image, photo D. Janová); d - detail of the worn gilding layer with underlying striations (photo E. Ottenwelter).

Obř. 4/62: Rolnička H78-2: a - celkový pohled (foto J. Sobek); b - vyznačení míst bodové mikroanalýzy na cípu rolničky (foto E. Ottenwelter); c - částečně hlazená až neuhlazená vrstva zlacení, mikrosnímek z rastrovacího elektronového mikroskopu (zobrazení BSE, snímek D. Janová); d - detail degradované vrstvy zlacení s povrchovým rýhováním (foto E. Ottenwelter).

Condition of the jingle bell, quality of work, wear

90% of the jingle bell is preserved. One petal is broken and incomplete. The material is in an advanced state of mineralization, but a metallic core is still present. Copper corrosion products, mainly copper oxides, are still covering regions of the gilding layer. The gilding layer has worn away in many places (*Fig. 4/62b*). The suspension system was perforated twice (*Fig. 4/62a*). The upper hole has worn away which suggests that the jingle bell was worn for a long time. It was pierced a second time to extend the life of the jingle bell and was gilded. The gilding layer is covering the previous hole which proves its anteriority.

Scanning electron microscopy and microanalysis

Micro-probe analysis performed on the metallic core of the jingle bell showed that the jingle bell was cast in bronze (Table 83). It was then gilded by fire-gilding with a gold and mercury amalgam. Striations (*Fig. 4/62d*) are visible on the surface underneath the gilding layer. It was probably done to remove oxides from the surface prior to gilding and to increase the adherence of the gilding layer. The gilding layer was burnished to obtain the smooth and reflective surface required. However, the burnishing was not done in recesses which could not be reached by the burnishing tool (*Fig. 4/62c*).

Components forming the jingle bell H78-2	Chemical composition [Wt. %]			
	Au	Cu	Sn	Hg
Bulk metal, abraded area, point 1	-	87.7	12.3	-
Bulk metal, point 2	-	93.5	6.5	-
Gilding layer, point 3	83.3	3.8	-	12.9

Table 83: Chemical composition of the jingle bell H78-2.

Tab. 83: Chemické složení rolničky H78-2.

8.2. DESCRIPTION OF THE JINGLE BELL H78-3 (Fig. 4/63)

This jingle bell has a spherical shape as well, but it is done with a completely different technology. It was formed like *gombiky* or beads with two hemispherical shells soldered together. The suspension system is composed of a loop made out of a round-sectioned wire of 1 mm in diameter inserted into the upper hemisphere through a hole and fixed to the hemisphere by a ring of plain round-sectioned wire soldered onto the upper hemisphere (Fig. 4/63a). The joining area of the two hemispheres is

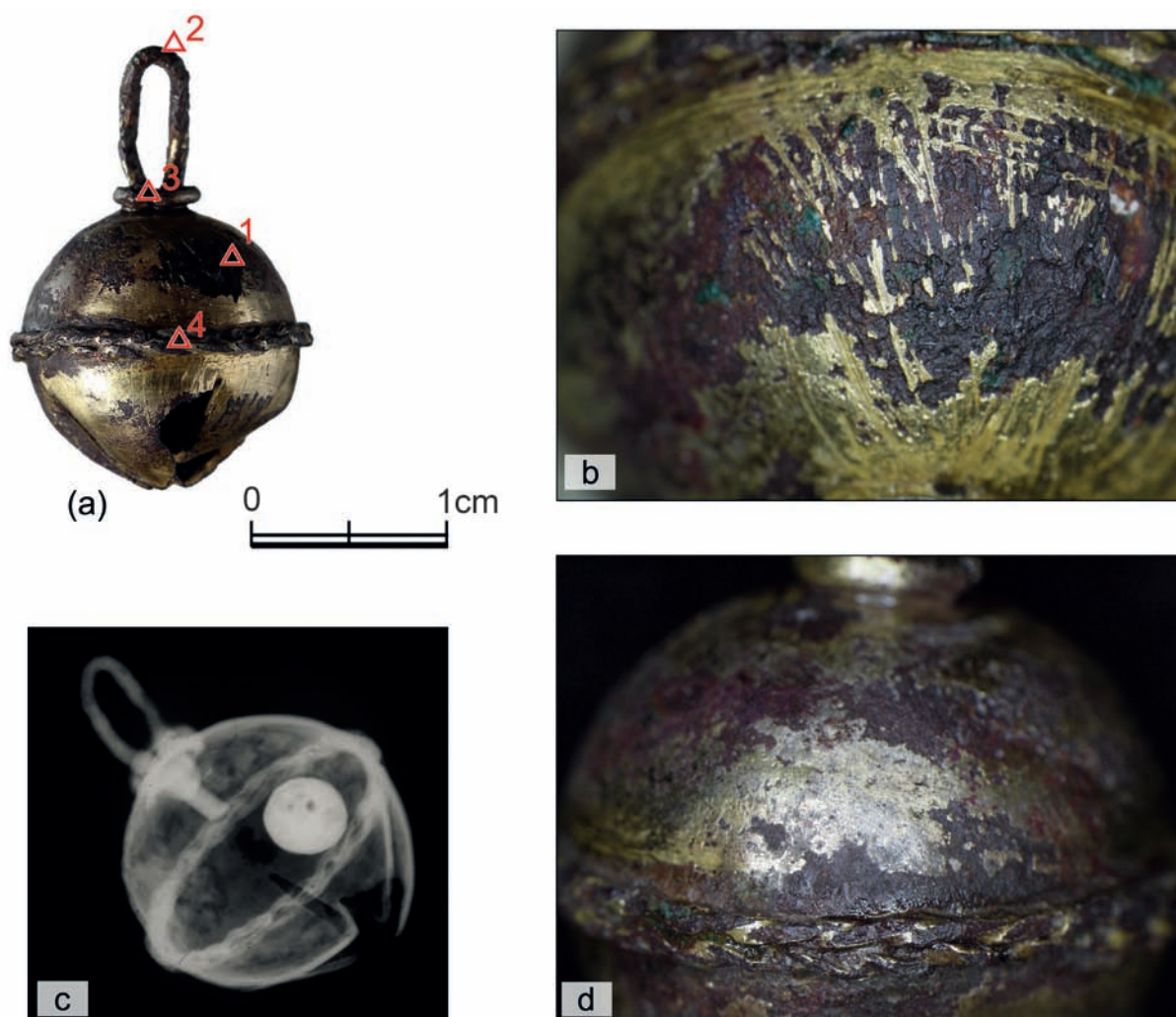

Fig. 4/63: Jingle bell H78-3: a - general view with analysed components (photo J. Sobek); b - worn gilding layer revealing underlying corroded bulk metal (photo E. Ottenwelter); c - X-radiograph of the jingle bell (D. Perlík); d - detail of the silvery area under worn gilding layer (photo E. Ottenwelter).

Obr. 4/63: Rolnička H78-3: a - celkový pohled s vyznačením míst bodové mikroanalýzy (foto J. Sobek); b - zkorodovaný základní kov v místě degradované vrstvy zlatění (foto E. Ottenwelter); c - rentgenový snímek rolničky (D. Perlík); d - detail stříbrité oblasti pod degradovanou vrstvou zlatění (foto E. Ottenwelter).

decorated by two ropes of double wires loosely twisted in opposite directions to create a braid-like ornament (*Fig. 4/63d*). The lower hemisphere has two slots forming a cross. The metallic pellet was probably inserted into the hemisphere before they were joined together. It is now fixed in place by copper corrosion products inside the jingle bell (*Fig. 4/63c*). This jingle bell is much lighter (weight: 1.8 g) than the previous one because of the technology used. In this case, it was easy to manufacture an artefact with thin walls (0.2 mm) by hammering a copper sheet and embossing two discs to form the hemispheres. Cast jingle bells are always much heavier because of the thickness of the walls. The jingle bell is composed of five different types of components.

Jingle bell H78-3		Dimensions [mm]
Hemispheres	Ø	15
Total	height	15
Loop	Length	8
Twisted wire	Ø	0.5
Loop's wire	Ø	1
Ring's wire	Ø	1
Hemisphere	thickness	0.2

Table 84: Dimensions of the jingle bell H78-3 and its components.

Tab. 84: Rozměry rolničky H78-3 a jejích částí.

Condition of the jingle bell

The jingle bell is complete. The cut lower hemisphere and the loop are mechanically deformed. The jingle bell has a very thin wall (0.2 mm) and therefore has been subjected to more mechanical deformation than was the previous cast jingle bell. The gilding layer has worn away in many places, in particular on the loop. Corrosion copper and silver corrosion products are present on regions of the surface. Silvery areas under the worn gilding (*Fig. 4/63d*) layer suggest a possible initial silver plating. The bulk metal is almost completely mineralized.

Scanning electron microscopy and microanalysis

Microprobe analyses performed on the different components of the jingle bell (*Fig. 4/63a*) have shown that the hemispheres, the loop, and the twisted wires were made with almost pure copper with a small amount of tin (Table 85) which is a suitable material for cold working. Copper was not detected on the ring. Analyses performed on the worn gilded layer on a silvery surface revealed the presence of silver. It is possible that an initial layer of silver was originally coating the jingle bell, silver being much easier to gild by fired gilding than a copper surface. However, this silver coating does not seem to be present on the whole artefact. It is mainly visible on one side of the upper hemisphere and in an area close to the soldered area of the two hemispheres. The two hemispheres must have been soldered with a silver copper hard solder. It is possible that the solder was accidentally spread on the upper hemisphere while soldering the two hemispheres together. The analysed silvery area composition is pretty close to eutectic composition which could suggest that the silver coating analysed here is rather the solder which was accidentally spread on the upper hemisphere rather than an initial silver plating.

Components forming jingle bell H78-3	Chemical composition [Wt. %]								
	Au	Ag	Cu	Hg	O	Cl	Si	Sn	Al
Hemisphere, bulk metal	-	-	87.8	-	10.5	-	-	1.7	-
Loop, bulk metal	-	-	87.8	-	9.9	-	-	2.3	-
Ring, bulk metal	-	-	87	-	10	-	1.7	-	1.3
Twisted wire, bulk metal			86.5	-	9.7	0.6	0.8	2.4	-
Gilded layer, hemisphere	79.7	3.5	3.8	13	-	-	-	-	-
Silver coating under gilding	1.6	58.1	36.9	3.4	-	-	-	-	-

Table 85: Chemical composition of the different components of the jingle bell H78-3.

Tab. 85: Chemické složení jednotlivých částí rolničky H78-3.

9. S-SHAPED TEMPLE RINGS

S-shaped temple rings are open rings formed with a round-sectioned wire of various diameters with a typical S-shaped ending. They were worn by children and woman, attached to a piece fabric on the head near the temple. They were worn by individuals from all social classes, but the material used to manufacture them depended very much on the wealth of their owner.

Description

A total of sixty two S-shaped temple rings were recovered in the “Lumbe Garden” cemetery. They are all made from a single wire and all have a small size (from 1 to 1.5 cm in diameter). However, the diameter of the wire varies considerably. The thinnest temple ring wires have a diameter of 0.8 mm while the thickest ones have a diameter of 2.8 mm.

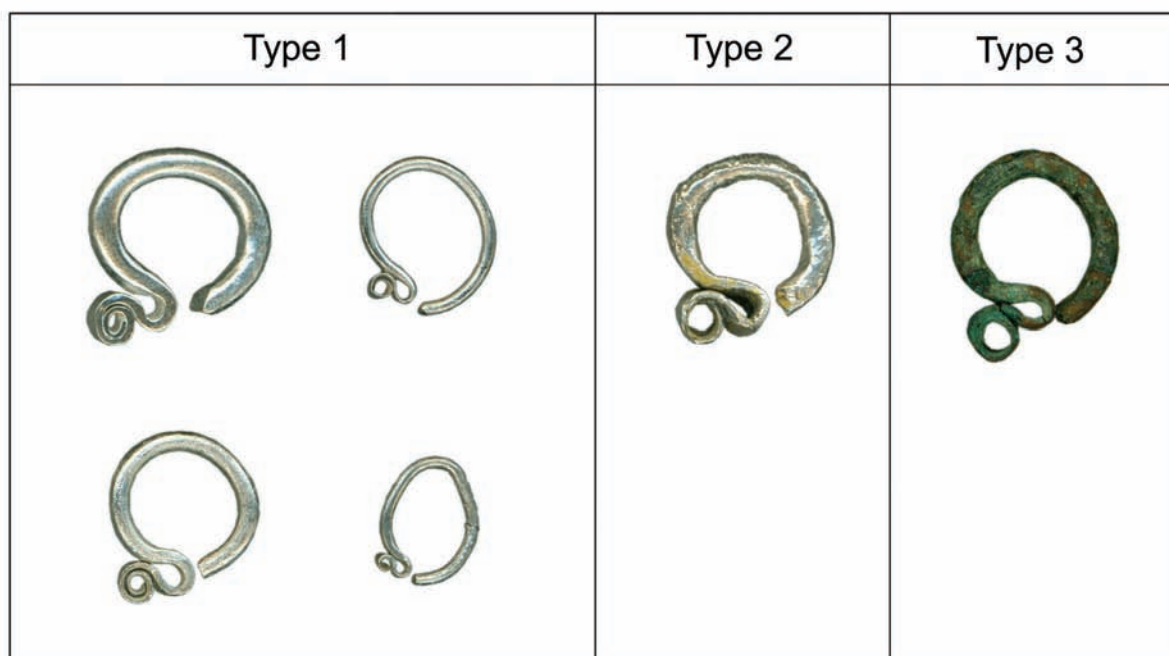

Fig. 4/64: Different type of S-shaped temple rings from the “Lumbe garden” necropolis: type 1 - Ag-Cu alloy; type 2 - gilt silver; type 3 - Copper alloy.

Obr. 4/64: Různé typy záušnic s esovitým zakončením z pohřebiště v Lumbeho zahradě: typ 1 – slitina Ag-Cu; typ 2 – zlacené stříbro; typ 3 – slitina mědi.

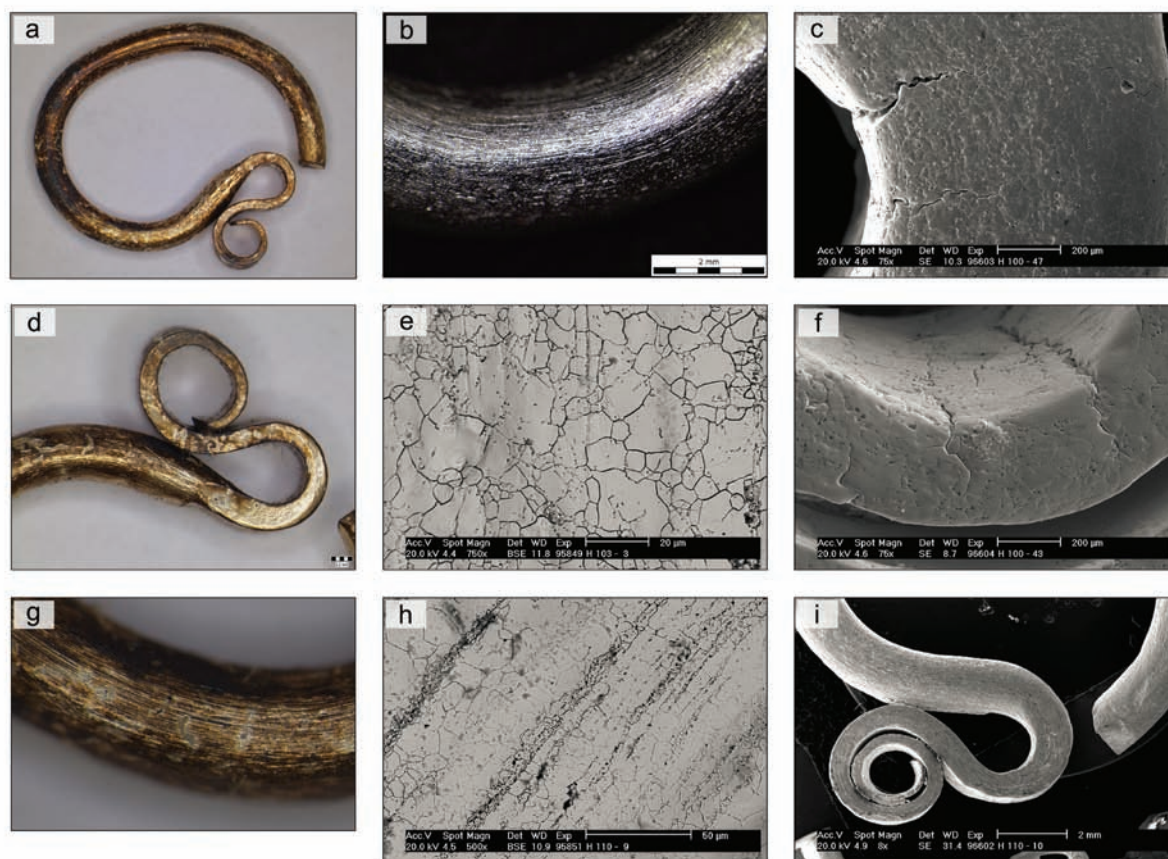

Fig. 4/65: S-shaped temple ring: a – general view temple ring H103-8 (photo E. Ottenwelter); b – multitude of parallel striations are visible on the surface, temple ring H100-40 (photo E. Ottenwelter); c – cracks, temple ring H100-47, SEM micrograph (SE image, photo D. Janová); d – tarnished surface of S-shaped temple ring H103-8, detail of the S-shaped end (photo E. Ottenwelter); e - etched surface, S-shaped temple ring H103-3, SEM micrograph (BSE image, photo D. Janová); f – cracks, temple ring 100-43, SEM micrograph (SE image, photo D. Janová); g – multitude of parallel striation visible on the surface, temple ring H103-8 (photo E. Ottenwelter); h – etched surface, S-shaped temple ring H110-9, SEM micrograph (BSE image, photo D. Janová); i – S-shaped end, detail, temple ring H110-10, SEM micrograph (SE image, photo D. Janová).

Obr. 4/65: Záušnice s esovitým zakončením: a – celkový pohled na záušnici H103-8 (foto E. Ottenwelter); b - četné paralelní rýhování patrné na povrchu, záušnice H100-40 (foto E. Ottenwelter); c – trhliny interkystalického charakteru, záušnice H100-47, mikrosnímek z rastrovacího elektronového mikroskopu (zobrazení SE, snímek D. Janová); d – zašlý povrch záušnice H103-8, detail esovitého zakončení (foto E. Ottenwelter); e - naleptaný povrch, záušnice H103-3, mikrosnímek z rastrovacího elektronového mikroskopu (zobrazení BSE, snímek D. Janová); f – trhliny interkystalického charakteru, záušnice H100-43, mikrosnímek z rastrovacího elektronového mikroskopu (zobrazení SE, snímek D. Janová); g – četné paralelní rýhování patrné na povrchu záušnice H103-8 (foto E. Ottenwelter); h – naleptaný povrch, záušnice H110-9, mikrosnímek z rastrovacího elektronového mikroskopu (zobrazení BSE, snímek D. Janová); i – detail esovitého zakončení, záušnice H110-10, mikrosnímek z rastrovacího elektronového mikroskopu (zobrazení SE, snímek D. Janová).

All the wires exhibit a very regular cross-section; a multitude of parallel striations are visible on the surface (*Fig. 4/65b, g*). Furthermore, temple rings found in the same grave, with few exceptions, all have the same diameter of wire. It is, therefore, evident that a drawplate was used to manufacture the wires. Although the earliest historical evidence of the drawplate is dated from the 12th century A. D. by Theophilus in his treatise on workshop practise, the invention of drawplates was certainly known and used much earlier. Iron and copper based alloy drawplates dating from the Viking period (9-10th centuries A. D) used to draw silver and gold wires were found in Norway (*Oddy 1977*, p. 81-82), in graves context in Bygland and By, in hoards in Mästermyr and in the 8th century Russian settlement site of Staraja Ladoga (*Armbruster 2010*, p. 201-202).

The weight of the S-shaped temple rings logically also varies considerably according to the diameter of the used wire. It is also incredibly similar to temple rings from the same grave which suggests that the amount of precious metal used was carefully measured. S-shaped temple rings have standard weights (0.25 g - 0.4g - 0.5g - 0.6 g - 2.7g) (Table 86). The heaviest silver specimens were, of course, found in the graves of the wealthiest individuals. Grave H100 contained a total of fourteen specimens of S-shaped temple rings with a wire of 2.7 mm in diameter, a weight of 2,7 g each making a total weight of 37.8 grams of silver which corresponds to the amount necessary to manufacture the whole necklace with *kaptorgy* of grave H82, nine big grape-shaped earrings, or a pair of big silver *gombiky* (see *Barčáková* in this volume). Three types of S-shaped temple rings from the “Lumbe Garden” cemetery can be distinguished according to the material used in their manufacture (*Fig. 4/64*). Type 1 comprises S-shaped temple rings made of binary Ag-Cu alloys. Type 2 comprises S-shaped temple rings made of gilt silver and type 3 comprises S-shaped temple rings made of copper alloy.

Condition of the S-shaped temple rings, quality

The S-shaped temple rings are in a rather good state of preservation, in particular those with a thick wire. However, they were all covered by a layer of tarnishing resulting from inappropriate storage and manipulation, and their surface was heavily etched because of past unsuitable chemical cleaning with alkaline cyanide solutions (*Fig. 4/65e, h*). The S-shaped ends are showing sign of intergranular corrosion probably initiated by stress induced corrosion resulting from intense cold working (*Fig. 4/65c, f*).

Scanning electron microscopy and microanalysis

Analyses were performed on forty nine specimens on a clean surface after reduction of silver and copper corrosion products present on the surface except in three cases (H30-3, H33-1, H103-3). Results showed that the majority of the S-shaped temple rings were made from solid silver alloys containing from 1.6 to 5 % of copper with an average of 3.7 % (Table 86). Metallography was not conducted on this type of jewel because no fragment was available. The surfaces of all the S-shaped temple rings were heavily etched by previous chemical treatment with alkaline cyanides. It is, therefore, possible that some of the copper was leached from the surface and that it was originally in higher concentration. Obtained results showed with few exceptions that the same material was used to manufacture the S-shaped temple rings enclosed in the same grave. Two S-shaped temple rings from grave H5 (H5-1 and H5-2) were gilded by fire-gilding (Table 87).

Grave	Number	State of the object	Ag	Cu	O	Cl	S	Wire's Ø in mm	Weight in gr.
H9	1		96.1	3.9	-	-	-	1.4	0.5
H9	2		95.3	4.3	-	-	0.4	1.4	0.5
H30	2		95.3	4.7	-	-	-	2.6	2.1
H30	3	tarnished	95.7	4.1	-	-	0.2	2.5	1.9
H33	1	tarnished	94	4.2	-	0.9	0.9	2.4	1.8
H84	7		98.2	1.8	-	-	-	0.8	0.25
H84	9		98.4	1.6	-	-	-	0.8	0.25
H85	4		94.8	5.2	-	-	-	2.3	1.25
H99	1		97.5	2.5	-	-	-	1.2	0.4
H99	2		98.3	1.7	-	-	-	1.7	0.6
H99	8		97.5	2.5	-	-	-	2	0.4
H99	9		97.5	2.5	-	-	-	1.2	0.4
H99	10		97.4	2.4	-	-	-	1.2	0.4
H100	40		98.2	1.8	-	-	-	2.7	2.6
H100	41		95.7	4.3	-	-	-	2.8	2.6
H100	42		97	3	-	-	-	2.8	2.7
H100	43		97	3	-	-	-	2.7	2.7
H100	44		97.2	2.8	-	-	-	2.7	2.7
H100	45		97.5	2.5	-	-	-	2.7	2.7
H100	46		97.6	2.4	-	-	-	2.8	2.8
H100	47		97.4	2.6	-	-	-	2.7	2.7
H100	48		97.2	2.8	-	-	-	2.8	2.6
H100	49		97.1	2.8	-	-	-	2.7	2.6
H103	3	tarnished	79.5	3.7	13.6	1.8	1.4	1.3	0.5
H103	4		95.6	4.4	-	-	-	1.4	0.5
H103	8		95.7	4.3	-	-	-	1.3	0.5
H103	9		95.8	4.2	-	-	-	1.3	0.6
H110	1		95.2	4.8	-	-	-	1.6	1
H110	2		95.8	4.2	-	-	-	1.7	1
H110	3		95.7	4.3	-	-	-	1.7	1
H110	4		96.7	3.3	-	-	-	1.7	1
H110	5		96	4.2	-	-	-	1.8	1
H110	6		95.4	4.6	-	-	-	1.7	1
H110	7		95.6	4.4	-	-	-	1.7	0.9
H110	8		96	4	-	-	-	1.7	1
H110	9		95.8	4.2	-	-	-	1.7	1
H110	10		95.6	4.4	-	-	-	1.7	1
H117	1		95.1	4.9	-	-	-	1.7	0.8
H117	2		95.1	4.2	-	-	-	1.8	0.9
H117	3		95.7	4.3	-	-	-	1.8	0.9
H117	20		95.8	4.2	-	-	-	1.8	0.8
H117	22	not complete	95.1	4.9	-	-	-	1.6	n. d
H123	2		95	5	-	-	-	2	1.1
H123	3		93.7	6.3	-	-	-	2.2	1.4
H123	4		95.8	4.2	-	-	-	2	1.1

Table 86: Chemical composition of the S-shaped temple rings made in solid binary Ag-Cu alloy

Tab. 86: Chemické složení esovitých záušnic ze slitiny Ag-Cu.

Grave	Number	Analyzed parts	Ag	Au	Cu	O	Wire's Ø in mm	Weight in gr.
H5	1	bulk metal	96.6	-	3.4	-	2.8	2.5
H5	1	plating	-	78.3	6.9	0.8	2.8	2.5

Table 87: Fire-gilded solid Ag-Cu S-shaped temple ring.

Tab. 87: Pozlacená esovitá záušnice ze slitiny Ag-Cu-S.

Three S-shaped temple rings (H30-1, H30-4, H120-12) were made of brass and one of a copper alloy (H99-3) (Table 88).

Grave	Number	Au	Cu	Fe	Zn	As	Sn	Pb	Wire's Ø, mm	Weight, gr.	Material
H30*	1	-	86.7	0.1	11.9	0.3	0.2	0.8	2.3	0.8	brass
H30*	4	-	91.3	0.1	8.2	0.2	-	0.2	2.1	0.9	brass
H99	3	0.3	75.9	-	14.9	-	8.9	-	n. d	n. d	bronze
H120*	12	-	93.3	0.1	5.8	0.2	0.1	0.6	1.8	n. d	brass

*results of XRF

Table 88: Copper alloy S-shaped temple rings.

Tab. 88: Esovité záušnice ze slitin mědi.

10. TEMPLE RINGS WITH AN EYELET

Temple rings with an eyelet are the most simple jewel from the set of the "Lumbe Garden" cemetery. They were manufactured with a very small amount of material. Just as S-shaped temple rings, they were worn by woman and children, attached to a piece of fabric near the temple. They are also formed of a round-sectioned wire, bent to form an open ring with a hammered end forming an eyelet, while the other is simply cut.

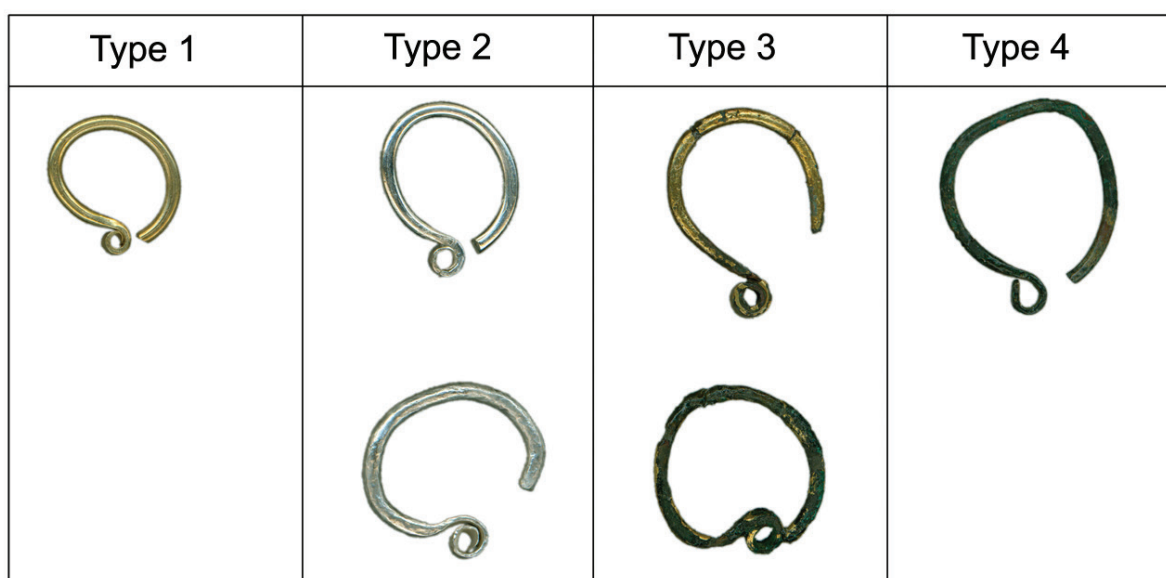

Fig. 4/66: Different types of temple-rings with an eyelet: Type 1 - Au-Ag-Cu alloy; Type 2 - Ag-Cu alloy; Type 3 - gilded copper alloy; Type 4 - copper alloy.

Obr. 4/66: Různé typy záušnic s očkem: Typ 1 – slitina Au-Ag-Cu; Typ 2 – slitina Ag-Cu; Typ 3 - zlacená slitina mědi; Typ 4 – slitina mědi.

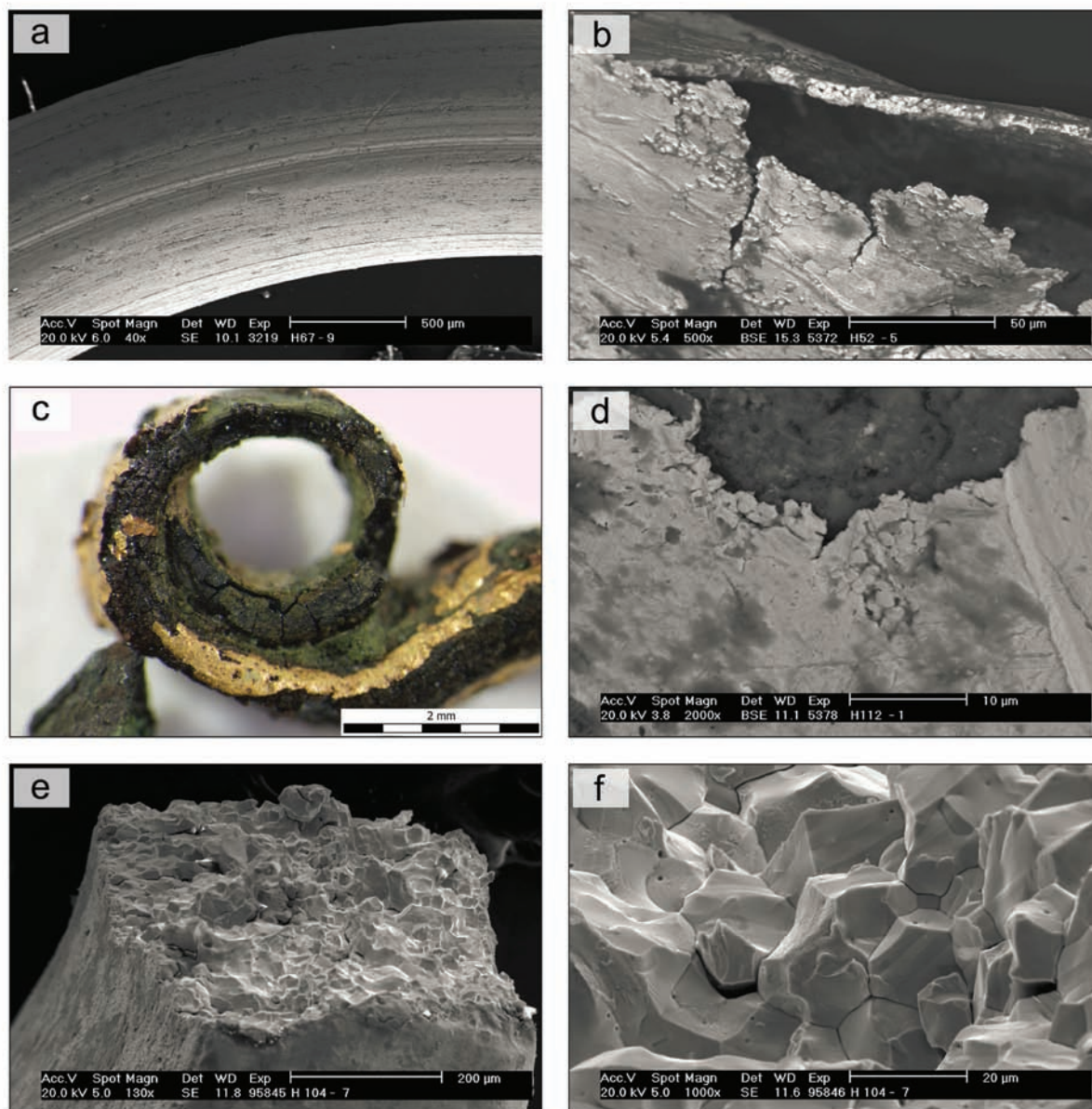

Fig. 4/67: Temple rings with an eyelet: a – parallel striations on the surface, temple ring H67-9, SEM micrograph (BSE image, photo D. Janová); b – gilding layer of temple ring H52-5, SEM micrograph (SE image, photo D. Janová); c – remains of gilding layer, temple ring H112-1 (photo E. Ottenwelter); d – gilding layer of temple ring, SEM micrograph (BSE image, photo D. Janová); e – intercrystalline fracture facet, temple ring H104-7, SEM micrograph (SE image, photo D. Janová); f – detail of intercrystalline fracture facet, temple ring H104-7, SEM micrograph (SE image, photo D. Janová).

Obr. 4/67: Záušnice s očkem: a – paralelní rýhování na povrchu, záušnice H67-9, mikrosnímek z rastrovacího elektronového mikroskopu (zobrazení BSE, snímek D. Janová); b – vrstva pozlacení záušnice H52-5, mikrosnímek z rastrovacího elektronového mikroskopu (zobrazení SE, snímek D. Janová); c – zbytky vrstvy pozlacení, záušnice H112-1 (foto E. Ottenwelter); d – vrstva pozlacení záušnice, mikrosnímek z rastrovacího elektronového mikroskopu (zobrazení BSE, snímek D. Janová); e – fazeta interkrystalického lomu, záušnice H104-7, mikrosnímek z rastrovacího elektronového mikroskopu (zobrazení SE, snímek D. Janová); f – detail interkrystalické lomové fazety, záušnice H104-7, mikrosnímek z rastrovacího elektronového mikroskopu (zobrazení SE, snímek D. Janová).

Description

Temple rings with an eyelet were found in twenty two graves. Several specimens are usually found within the same grave numbering up to nine (grave H1) or even eleven (grave H67) in quantity. However, they can also be found as unique specimen (grave H51) or as a pair in the graves of modest individuals (grave H46).

They are manufactured with a small amount of material of only 0.2 to 0.7 gr. They all have thin wires from 0.6 to 1.5 mm in diameter. The diameter of the wire and the weight of the temple ring are, with few exceptions, homogeneous in each grave. Typical parallel striations on the surface were observed in stereomicroscope, in particular on the temple ring from graves H104 and H67. These parallel striations which characterize the surface of the drawn wires are particularly visible on the electrum temple rings (grave H67, *Fig. 4/67a*) which are even softer than the silver ones. However, the quality of the temple ring varies. Several temple rings from grave H1 (H1-1, H1-2, H1-7), for example, were not bent on an anvil and have an irregular open ring. Temple rings with an eyelet from the "Lumbe Garden" cemetery can be distinguished in different types mainly by the material they were manufactured from. Type 1 comprises temple rings with an eyelet made of ternary Ag-Au-Cu alloy. Type 2 temple rings with an eyelet made from binary Ag-Cu alloy. Type 3 comprises temple rings with an eyelet made of gilded copper alloy and finally type 4 comprises temple rings with an eyelet made of copper alloy (*Fig. 4/66*).

Condition of the temple ring with an eyelet

Temple rings made in silver alloy were tarnished and were suffering from intergranular corrosion (*Fig. 4/67e, f*). Gilded copper alloy temple rings had their gilding layer in a poor state of preservation. It was flaking (*Fig. 4/67 b*) and was lost on most on the surface (*Fig. 4/67c*).

Scanning electron microscopy and microanalysis

The majority of the temple rings with an eyelet recovered in the "Lumbe Garden" cemetery are made of solid silver with an average content of 3.8 % of copper (Table 89). A higher content of copper (up to 9.3 %) was detected in two specimens from grave H85 (H85-1, H85-6). All the temple rings discovered in grave H104 as well as one specimen from grave H85 (H85-1) were made in ternary alloy containing silver, gold, and copper. Temple rings from grave H104 have a gold content of approximately 4.6 %, while the temple ring from grave H85 has only 2.8 % of gold. It is interesting to note that analysis of copper detected in a fresh crack of the wire on the core of temple ring H104-7 showed a copper content twice as high as the copper content detected on the surface which was leached by cyanides (Table 90). We can presume that the copper content of the silver alloy used was, therefore, higher than the content measured on surfaces. Eleven temple rings with an eyelet were manufactured in electrum with about 8% of copper (grave H67) (Table 91). Three specimens were manufactured with copper alloy and were gilded by fire-gilding (H52-5, H112-1, H112-2) (*Fig. 4/67b, c, d*) (Table 92). Finally, two specimens found in the graves of poor individuals were manufactured from copper alloy (H46-1, H46-2) and one from brass (H80-1) (Table 93). Analyses made on these three last temple rings were performed by XRF on corroded surfaces. It is, therefore, impossible to state the exact chemical composition of the alloys used.

Grave	Number	State of the object	Ag	Cu	Wire's Ø in mm	Weight in gr.
H1	1		96.2	3.8	1.5	0.7
H1	2		96.3	3.7	1.5	0.7
H1	3	tarnished	97.1	2.9	1.7	0.7
H1	4	tarnished	97.1	2.9	1.6	0.7
H1	6		96.6	3.4	1.5	0.6
H1	7		95.7	4.3	1.5	n. d
H1	8		95.8	4.2	1.5	n. d
H1	9		96.1	3.9	1	n. d
H7	17		97.5	2.5	0.8	0.2
H7	18		97.9	2.1	0.8	0.2
H11	1		97.4	2.6	1.4	n. d
H11	2		97.4	2.6	1.2	0.4
H11	3		98	2	1	0.2
H24	2		96.5	3.5	1.3	n. d
H24	3		96.4	3.6	1.4	0.4
H24	4		96.4	3.6	1.3	n. d
H51	1		96.8	3.2	1.5	0.6
H85	1		90.7	9.3	0.8	n. d
H85	2		95.3	4.7	0.6	n. d
H85	3		95	5	0.8	n. d
H85	6		91.9	8.1	0.6	n. d
H103	10		96.5	3.5	1	0.4
H107	1		97.3	2.7	1.3	0.4
H107	2		97.1	2.9	1.2	n. d

Table 89: Solid silver-copper temple ring with an eyelet.

Tab. 89: Záušnice s očkem ze slitiny Ag-Cu.

Grave	Number	Analyzed part	Ag	Au	Cu	Wire's Ø in mm	Weight in gr.
H85	5		92.1	2.8	5.1	1	0.2
H104	6		94.4	4.5	1.1	1.3	0.5
H104	7	core	91.4	4.7	3.9	1.3	0.5
H104	8		94.1	4.5	1.4	1.3	0.5
H104	9		93.7	4.7	1.6	1.3	0.5
H104	10		93.9	4.3	1.8	1.3	0.5
H104	11		93.9	4.9	1.2	1.3	0.5

Table 90: Solid ternary alloy Ag-Au-Cu temple ring with an eyelet.

Tab. 90: Záušnice s očkem ze slitiny Ag-Au-Cu.

Grave	Number	Au	Ag	Cu	Wire's Ø in mm	Weight in gr.
H67	1	59.5	32.5	8	1.2	0.5
H67	9	56.9	35.7	7.4	1.2	0.5

Table 91: Electrum made temple rings with an eyelet.

Tab. 91: Záušnice s očkem ze slitiny zlata a stříbra (elektrum).

Grave	Number	Analyzed part	Au	Ag	Hg	Cu	Sn	Pb	O	P	S	Cl	Wire's Ø in mm	Weight in gr.
H52	5	plating	78.3	2.1	15.9	3.7	-	-	-	-	-	-	1.2	n. d
H52	5	core	-	2.6	-	40.5	13.2	7.2	28.2	4	1.5	2.8	1.2	n. d
H112	1	plating	76	3.1	11.7	9.2	-	-	-	-	-	-	n. d	n. d
H112	1	core	-	-	-	67.6	13.1	6.1	13.2	-	-	-	n. d	n. d

Table 92: Fire-gilded copper alloy temple rings with an eyelet.

Tab. 92: Pozlacené záušnice s očkem ze slitiny mědi.

Grave	Number	Analyzed part	Cu	Sn	Zn	Pb	Fe	As	Ag	Au	Wire's Ø in mm	Weight in gr
H46	1*	corroded	65.7	27.7	-	5.4	0.5	0.5	0.1	0.1	n. d	n. d
H46	2*	corroded	47.3	45.5	0.2	6	0.3	0.2	0.4	0.1	n. d	n. d
H80	1*	corroded	80	5.7	12	1.8	0.5	-	-	-	n. d	n. d

*results of XRF analyses

Table 93: Copper alloy temple rings with an eyelet.

Tab. 93: Záušnice s očkem ze slitiny mědi.

CONCLUSION

A total of 136 jewels from the “Lumbe Garden” cemetery at Prague Castle were analysed within this study, including 10 *gombiky*, 16 earrings, 8 beads, 5 *kaptorgy*, 1 locket and 2 jingle bells, representative of the different categories of jewels in the necropolis, as well as 53 S-shaped temple rings and 41 temple rings with an eyelet.

In order to understand the construction of the jewels and the technology used in their manufacture, the jewels were first examined under a microscope and then X-rayed. Exploded views of the main type of jewel showing their different components were then created. Analyses were performed on each type of component and solder area in order to determine the material and solder technique used. They were performed on clean surfaces after the reduction of the tarnish layer present on silver alloys and gold alloys, which can otherwise distort results. A metallographic examination was performed on available fragments to gain more accurate results about the composition of the bulk metal and gilding techniques. Finally, each component was measured in order to evaluate the quality of the jewels and identify components manufactured to make the jewels.

All the jewels from the “Lumbe Garden” cemetery, apart from temple rings and two cast jingle bells (H78-2, H43-1), are multi-component artefacts made by hammering, drawing, cutting, embossing, twisting and soldering discs, wires, strips, sheets of metal, bosses and granules.

Silver with a small amount of copper (an average of 3-4 %) is the prevailing material used to manufacture the jewels from the “Lumbe Garden” cemetery. All the *kaptorgy*, the majority of earrings, beads and temple rings were manufactured with this material. Fluctuations in the copper content occur from one component to another within the same jewel, showing that the different components were manufactured in advance and used as needed. Metallographic examination performed on

available fragments of silver jewels (see Kolářová – Děd – Ottenwelter in this volume) documented the presence of different elements in the silver matrix, indicating a different provenance of silver ore and/or soldering technology. A ternary alloy of Ag-Au-Cu with approximately 3 % of both copper and gold was used to manufacture two beads (H100-27, H100-20).

Gilded copper-based alloy were used to manufacture the majority of *gombiky* as well as jingle bells, two grape-shaped earrings (H31-1) and 3 temple rings with an eyelet (H52-5, H112-1, H112-2). Pure copper was used to manufacture *gombiky* H84-1 and H104-4. Almost pure copper with a small tin content (2 - 3 %) was used to manufacture *gombiky* H108-2, H115-8, H74B-2, H53-14, H99-5 and jingle bell H78-3. Lead particles were detected in the corroded hemisphere of *gombik* H99-5. Arsenic and antimony were detected in the clamp and the ring from *gombik* H104-4. Antimony and lead were also detected in preserved metallic particles in the hemisphere of *gombik* H104-3. Arsenic was detected in the bezel of *gombik* H74B-2 as well as in two filigree rings from earring H31-1. Locket H52-2 was manufactured with a copper-based alloy containing a small amount of silver (2 %). Jingle bell H78-2 was made of bronze. The results of analyses of gilded copper-based jewels show that different copper ores and alloys were used to manufacture the jewels. Variations can also occur within the same object, as was observed on the components forming the suspension system of the *gombiky* (H84-1, H115-8, H74B-2, H104-4).

Ternary Au-Ag-Cu alloys were used to manufacture a limited number of jewels found mainly in grave H16 but also in grave H53 and H67. The jewels concerned are *gombiky* (H16-14), 13 zoomorphic earrings from grave H16 (H16-3), 2 beads from grave H16 (H16-18), a pair of globular earrings (H53-3, H53-4) and 11 temple rings with an eyelet from grave H67 (H67-1, H67-9). *Gombik* H16-14 was made with an alloy containing up to 80 % gold, 15 % silver and 5 % copper, while other jewels have a lower content of gold (from 49 – 59 % gold, 32 - 44 % silver and around 7 – 9 % copper.). *Gombik* H16-14 has a close parallel in terms of material used as well as typology with *gombiky* 1122a/57 and 1122b/57 from grave 505 from Mikulčice (Kavánová 2009, p. 129-132) and a pair of *gombiky* from Želénky (Profantová - Frána 2003, p. 52). Other jewels in solid gold alloy have a lower content of gold and a higher content of silver closer to the material used to manufacture the chain of the medallion (inv. no. 118743) and two grape-shaped earrings (inv. no. 11443, inv. no. 11445) from Želénky (Profantová - Frána 2003, p. 52).

Gilded silver was used to manufacture earring H104-1, globular earrings (H53-1, H53-2), the chain of the *kaptorga* H16-19a, and two S-shaped temple rings (H5-1, H5-2).

Decoration techniques include chasing and repoussé, granulation and filigree work, the use of glass cabochons, applied bosses and gilding. The chasing and repoussé technique concerns almost exclusively *gombiky* in gilded copper alloys (H84-1, H115-8, H104-2, H108-2, H104-4, H99-5) or silver (H115-7) and a *kaptorga* (H117-14). Granulation work is associated with all the earrings, beads (H100-18, H25-2, H16-18, H116A-3) and *kaptorgas* (H82-14, H16-19a). Filigree work was mainly used to decorate or manufacture beads (H100-27, H82-13, H5-3, H53-18), *kaptorgy* (H82-15, H53-10), two kinds of *gombiky* (H16-14, H53-14), earrings as part of the elbow, lower arch decoration (H85-5, H115-1, H84-8b, H115-2, H104-14) and lower grape (H31-1, H31-2). Applied bosses were used to decorate beads (H53-18, H116A-3) and one *kaptorga* (H16-19a).

Gilding was used extensively on copper alloys. The majority of *gombiky* (80%) are gilded. Three copper alloy temple rings with an eyelet, jingle bells (H78-2, H78-3) and lockets (H52-1, H52-2) were also gilded (H52-5, H112-1, H112-2). Silver gilding likewise took place in four cases: two globular earrings (H53-1, H53-2), a grape-shaped earring (H104-14) and the chain of a *kaptorga* (H16-19a). The gilding was performed by the fire-gilding method in all of these cases.

Glass cabochon decoration is present on *gombiks* (H16-14, H16-15, H74B-2, H53-14, H53-15) and on one *kaptorga* (H16-19a).

The number of different kinds of components used in the manufacture of various types of jewels fluctuates according to the number of base components forming the plain jewels and the complexity of the decoration of the specimens within each category of jewels. If we consider the number of different kinds of components needed to manufacture the plain jewels without the decoration, we note that beads are the simplest jewels. A minimum of two kinds of components are usually needed to manufacture plain beads (hemisphere or shell, ring). *Kaptorgy* need a minimum of four components (front plate, back plate of the bottom, side and top of the cover), with the exception of *kaptorga* H53-10, which has only three (main folded sheet, cover sheet, “tear-shaped” plate). Three to five

different components (loop, ring, clamp, hemisphere pellet) are needed to manufacture *gombiky*. Four to six kinds of components are needed to manufacture earrings, while five different types of components (back plate, loop, ring, rivet, bezel) are used to make lockets.

If we also count the components needed for the decoration of the jewels, their number increases considerably according to the complexity of the decoration. *Gombik* H74B-2 features six different kinds of components, *gombik* H53-14 has eight, and *gombik* H16-14 has a total of nine different kinds of components. The total number of components can reach nine in the case of the most complex grape-shaped earrings (H115-14, H115-5, H84-8b, H115-2) as well as highly decorated beads (H100-27, H53-18, H116A-3), and up to ten and twelve for highly decorated *kaptorgy* (H82-15, H16-19a, H53-10). If we consider the total number of components soldered to form the jewels, complex jewels are highlighted even more. *Gombik* H16-14 features a total of 51 components, whereas *gombik* H99-5 has four components. Of course, the time-consuming chasing and repoussé decoration techniques must be considered in the complexity of the jewel, too. In the case of earrings, the total number of components varies from 31 for the simplest specimens (H116A-1) up to 234 for the more complex specimens (H115-4). The total number of components used to manufacture the beads also varies according to the extent of decoration. The simplest bead (H82-13) has a total number of 32 components, while beads H100-27 and H100-18 have up to 320 components. The total number of components also increases significantly with the decoration in the case of *kaptorgy*. From three to four components required to make the body of the *kaptorgy*, the number of components including the decorative components can reach several hundred in total. The soldering of all these components is extremely time-consuming and risky, and requires high skill, which is proving that very talented goldsmiths worked on these objects and that these items are luxurious jewels.

The weight of precious metal used is another parameter for comparing jewels. This parameter can be taken into account only in the case of jewels made of solid alloys, excluding those which are plated. If we compare jewels made of solid silver, we see that the amount of silver fluctuates according to the category of jewels manufactured but also within each category of jewels according to the size of the jewels, the thickness of the metal sheet or diameter of wire used. The weight of S-shaped temple rings, for instance, varies from 0.4 g for the lightest specimens (H99-1, H99-8, H99-9, H99-10) up to 2.7 g for the heaviest (H100-40-49). The amount of silver used to manufacture the different *kaptorgy* fluctuates from 3 g (H82-15), to 10 g (H82-14) and can reach almost 30 g (H16-19a). A total of 15 g of silver was needed to manufacture *gombik* H115-6. The amount of silver used to manufacture beads is rather low in the case of bead H25-2 and bead H100-27, which used only 2 g of silver. These two beads illustrate well how the goldsmith managed to use as little material as possible by using either a very thin sheet of metal (44 µm - H25-2) or by forming the bead with an open filigree work technique (H100-27). The amount of silver used to manufacture the grape-shaped earrings varies considerably. The smaller specimens weight only 0.6 g (H89-3) while the heaviest (H115-14) can reach 4.3 g. The average amount of silver needed to manufacture globular earrings is 2.5 g, which is almost half as much as grape-shaped earrings of equivalent size (4 g).

The solder used to join copper alloy components is a hard silver-copper solder often close to the eutectic composition (Ag 78%, Cu 22%). This solder was identified on *gombiky* (H84-1, H115-8, H104-3, H108-2, H104-4, H99-5) and on a grape-shaped earring (H31-1). The technology of soldering silver alloys was probably harder to evidence because of past chemical treatment performed on the artefacts that had leached most of the copper on the surface and solder area, the corrosion process, which tends to create an enrichment of silver on the surface, and finally by the phenomenon of copper diffusion that took place in the surrounding bulk metal during the numerous cycles of heating necessary to solder all the different components together. Nevertheless, it was possible to detect a higher content of copper in soldering areas by metallographic examination and by surface analysis on a few specimens (H5-3, H89-3, H84-5, H115-1, H84-8b), which demonstrates that copper compounds were involved in the soldering technique. A significant higher percentage of copper was detected in the solder area of jewels made in a ternary Au-Ag-Cu alloy (H16-3, H16-18), which shows that copper was involved in the soldering of ternary Au-Ag-Cu components as well.

The variation in the component size and in the material used to manufacture them show that components, in particular granules and filigree but also hemispheres, bosses, loop and clamps, were semi-finished products prepared in advance, which were used as needed and sometimes made from different ores.

Differences in quality, in the used raw material, the number of components and technology can be distinguished in the different categories of jewels, documenting that the raw material came from different locations, that various technology was used and that a number of goldsmiths worked on this assemblage of jewels.

Variations in the bulk metal used to manufacture the different components of the *gombiky* (pure copper, copper alloys with a small amount of tin (2-3 %), the presence of lead, arsenic, and antimony) clearly demonstrate that different copper ores were used to manufacture these *gombiky*. Furthermore, silver was detected in most cases in the gilding layer, in a percentage fluctuating from 2.3 to 6.5 %. However, it was not present in the gilding layer of *gombik* H84-1. Further differences are visible in the thickness of the preserved gilding layer measured at the cross-section of available fragments. The average thickness of the recorded gilding layer is 7-8 μm , and is two- to three-times thicker in the case of *gombik* H104-3 (19.2 to 28.8 μm). The different number of components from which the *gombiky* are composed also highlight differences. The usual number of components forming the suspension loop is three (loop, clamp, ring). However, in the case of *gombiky* H74B-2, H53-14 and H99-5 we have only two components (loop and ring). *Gombik* H16-14 has a total of seven components forming the suspension system. Some *gombiky* have a pellet inside them (H84-1, H104-4), while others do not (H108-2, H99-5).

The size of the *gombiky* is also significant. The two largest pairs of *gombiky* (H115-6, H115-7 and H84-1, H84-2) have very standardized components. The chased and repoussé decoration is very similar. Despite the fact that they are made of different material, they seem to have been made by the same goldsmith. *Gombiky* from grave H108, H104 and H115 were manufactured by a very skilled goldsmith. The chased decoration is perfect in all cases, while *gombik* H104-3 has low quality chased decoration. It is obviously a poor imitation of Great Moravian-type *gombiky*, perhaps modelled after a similar yet larger type of *gombik* found in grave 73 in Nitra-Zobor (*Beeby – Buckton – Klanica 1982*, p. 18). The unusual thickness of the gilding layer and presence of lead in the copper alloy used to manufacture the hemisphere also highlight the singularity of this *gombik*. *Gombik* H84-1 is probably a local product, since the gilding layer does not contain silver, unlike other gilded copper alloys from the “Lumbe Garden” necropolis similar to Great Moravian jewels. However, the peacock motif is also present on *gombiky* from the Great Moravian context in Staré Město (grave 251/49), for example (*Beeby – Buckton – Klanica*, p. 16). *Gombik* H104-4 has a direct parallel with a *gombik* found in the Royal Garden of Prague Castle (*Tomková 2006*, p. 11). *Gombiky* H104-4, H108-2, H115-8 have parallels in terms of the quality of work and technology in Great Moravian production of gilded copper alloy *gombiky* from Mikulčice (*Poulik 1963*), Kopčany (*Baxa – Hošek – Ottenwelter 2010*, *Hosek et al. in press*) and Staré Město (*Hrubý 1965*). *Gombik* H16-14 is certainly the most precious and complex type of *gombik* present in the assemblage from the “Lumbe Garden” necropolis. It is made of a solid Au-Ag-Cu ternary alloy with a variable gold-silver content. Analyses performed on a corrugated strip detected up to 80.2 % gold, 15.2 % silver, and 4.6 % copper, while analyses performed on other parts showed a lower content of gold (51 - 61 %), a higher percentage of silver (30 - 35 %), and a higher concentration of copper (7.8 to 16 %). The fluctuations in the results from different components can be explained by the fact that the solder used to join the large components (ternary alloy of Au-Ag-Cu) may have spread on analysed components or that an imperceptible layer of tarnish composed of silver and copper corrosion products are distorting the results. The detected content of gold is from 10 to 20 % more than in results obtained by Smetánka and Staňa in their X-ray fluorescence analyses (*Smetánka - Staňa 1996*, p. 140). This jewel has nothing in common with other jewels from the “Lumbe Garden” necropolis in terms of typology and material used or in terms of the number of components (51 in total). The other type of *gombik* which has a close parallel in the jewels of Mikulčice, though from the typological, is *gombik* H53-14, which can be compared to *gombik* 4883/65 from grave 827 from Mikulčice (*Kavánová 2009*, p. 129). However, *gombik* H53-14 is not made of a solid gold alloy but a gilded copper alloy. A similar *gombik* made of silver was found in grave 136 in Pohansko u Břeclavi (*Čáp – Macháček – Špaček 2011*, p. 102) and in Staré Město, in grave 25/48 in the ‘Na Valach’ burial ground (*Galuška 2013*, p. 185). *Gombik* H74B-1 and H74B-2 can also be compared to copper alloy *gombiky* from grave 76 from Mikulčice (*Poulik 1963*, p. 150).

Among the earrings made of silver and, more precisely, among the grape-shaped earrings representing the most numerous type of earrings of the “Lumbe Garden” necropolis, we can distinguish very elaborate earrings (H115-1, H84-5, H115-2, H115-14), which have up to nine different kinds

of components, attesting a remarkable knowledge and skill in the art of granulation work, but also low quality work (H84-3) and very simple specimens (H116A-1) with only five different kinds of components. Direct parallels of these earrings, especially the earrings from grave H115, can be found in Great Moravian sites such as Mikulčice (in grave 183 and 680 - *Poulik 1963*, p. 172), Staré Město (*Hrubý 1965*) and Želénky. Gilt silver was used to manufacture one specimen of a grape-shaped earring (H104-14). Earring H104-14 also has a direct parallel in gold earrings from Mikulčice (676-85a and b/75) and in an earring found in grave 28 in Klecany II (*Profantová et al. 2010*, p. 193).

Two pairs of globular earrings were found in grave H53. The pair of seven-globe earrings (H53-3, H53-4) was made in solid ternary Au-Ag-Cu alloy (59.8 % Au, 31.2 % Ag, 9 % Cu), while the pair of six globe-earrings was made of gilt silver with a central wire of almost pure gold (90.2 %) with silver (9.8 %). The results of analyses of specimen H53-3 differ from the results of analyses performed by Z. Smetánka and Č. Staňa (*Smetánka - Staňa 1996*, p. 140) by X-ray fluorescence. Although the copper content is similar, analyses performed by SEM/EDS after the removal of the thick tarnish layer covering the surface revealed a gold content 7.3 % higher and a silver content that was 8.4 % lower. The difference in the results of analyses can easily be explained by the fact that analyses performed by Z. Smetánka and Č. Staňa were certainly conducted on a tarnished surface covered with silver corrosion products, which distorted the results. Analyses of specimen H53-4 showed the same difference in gold and silver content. A higher percentage of copper was detected in analyses performed by Z. Smetánka and Č. Staňa. With copper and silver corrosion products present in the tarnish covering silver alloy artefacts (*Ottewilte 2014*), it is not surprising that analyses performed on a tarnished surface detected more silver and copper than the actual metal composition. The quality of seven-globe earring H53-3 is very low compared to H53-4, with many visible defects. It is obvious that this work was done by a less experienced person, probably an apprentice. Earring H53-4, on the other hand, has a high level of craftsmanship. Analyses performed on specimen H53-1 showed that the bulk metal of the different components forming the earring, apart from the central wire, are made of binary Ag-Cu alloys with 3 - 5.1 % copper. The central wire is made from high quality gold (90.2 %) alloyed with silver (9.8 %). The earring was fire-gilded, except for the wire. X-rays of the earring also revealed that the goldsmith cheated on the quality of the internal wire to save precious metal and used several thinner pieces of wire. The overall quality of the earring is very high though. It is obvious that it was manufactured by a highly skilled goldsmith who knew how to perfectly imitate solid gold earrings. It is interesting to note that the wire, the material quality of which could be easily checked in the cross-section, was made of high quality gold. Analyses performed on earring H53-2 also revealed the presence of a gilt silver earring. X-fluorescence analyses performed by Z. Smetánka and Č. Staňa (*Smetánka - Staňa 1996*, p. 140) could not distinguish the solid gold alloy from the compact gilding layer as mentioned by the authors themselves. Defects on the gilding layer were noticeable only under an electron scanning microscope, which offers magnification up to 30 000 times and the possibility of performing analyses on very precise points. Although defects in the gilding layer were not visible on earring H52-2, the granule's lumpy surface suggested that a thick amalgam was pasted on them. Mercury was detected on the surface, which confirmed that the earring was also fire-gilded. Analyses performed in a crack also showed a higher content of silver, confirming that both specimens were gilt silver. Both earrings are of excellent quality. The granule size is very homogeneous and the granulation work is perfectly executed. No solder flooding is visible. The gilding layer is thick, regular, and in an astonishing state of preservation. We can conclude that the goldsmith who manufactured these two earrings handled the granulation and fire-gilding techniques perfectly. These earrings have a direct typological parallel in earrings from Mikulčice, Rajhrad and Staré Město (*Galuska 2013*, p. 188), Kopčany (*Baxa - Hošek - Ottewilte 2010*, p. 510) as well as Klecany (*Profantová et al. 2010*, ill. 65, grave 53), but the latter earrings are made of silver.

Pseudo-globular earrings (H82-5) are among high-quality earrings. The thinness of the shell (0.1 mm) rendered the granulation work extremely risky. High skill must have been required to manufacture this type of earring.

The zoomorphic earrings from grave H16 were manufactured in ternary Au-Ag-Cu alloy (52.8 % Au, 40 % Ag, 7.2 % Cu) which is relatively similar to the alloy used to manufacture the seven-globe earrings.

Beads H100-27, H53-18 and H116A-3 are the more complex beads and are composed of 8 to 9 different types of components. Bead H100-27 is a masterpiece. Beads H25-2 and H16-18 are

also excellent quality artefacts. Bead H82-13 is certainly the simplest bead from the assemblage. It has a direct parallel in a bead found in grave 14 in Klecany II (*Profantová et al. 2010*, p. 187) and Prague Castle, burial mound 'Jízdárna', grave 73-51 (*Tomková 2006*, p. 70).

Five specimens of *kaptorgy* were recovered from the "Lumbe Garden" necropolis. The simplest ones (H82-14, H117-14) were manufactured using five different kinds of components, while the more complex specimens were manufactured with ten (H16-19a, H53-10) to twelve components (H82-15). The majority of them have two distinct parts: a box and a cover manufactured with folded sheets of silver and forming a trapezoidal empty container. The box and the cover are perforated in the upper part to allow a metallic chain to go through to hold the *kaptorga* closed. One *kaptorga* is made with a rectangular sheet with a thickness of 0.2 mm, forming an empty trapezoidal container with a 'tear-shaped' section. The ends of the sheet overlap to form a little hoop which holds the folded sheet in position. The front, sides, top and bottom of the *kaptorga* are highly decorated with granulation work (H82-14), adorned with filigree and glass cabochon decoration (H16-19a, H82-15) or with zoomorphic decoration made with filigree (H53-10). *Kaptorga* H117-4 is decorated on the front side and on the cover with stamping and chasing. The sheet metal used to manufacture the *kaptorga* is thin (0.2 mm), while an even thinner sheet (0.1 mm) was used to manufacture *kaptorga* H117-14. Sheets that were three times thicker were used to manufacture *kaptorga* H16-19a. The quality of the *kaptorga* varies as well. *Kaptorga* H82-14 and H117-14 are of rather poor quality, while *kaptorga* H82-15 and H53-10 are of a very high quality. *Kaptorga* H16-19a was made with a thick wall and, therefore, was expensive with respect to material; however, the granulation decoration is rather clumsy. *Kaptorga* H117-14 has very close parallel in the *kaptorga* from grave 22 from Klecany II (*Profantová et al. 2010*, p. 190). However it is made with a different silver alloy. The *kaptorga* from Klecany was made of a silver alloy containing 3.5 % copper and 2.5 % gold (*Děd - Šilhová 2005*, p. 46). *Kaptorga* H53-10 has a close parallel in *kaptorgy* found in grave 106 b in Stará Kouřim (*Šolle 1966*, p. 153), in grave 268 in Libice (*Huml - Starec 1994*) and in Prague in grave 2 on Wenceslaus Square (*Huml - Starec 1994*, p. 459). *Kaptorga* H84-14 has a direct parallel in the *kaptorga* found in grave 5 in Wenceslaus Square (*Huml - Starec 1994*, p. 503).

Copper with a small amount of silver (2 – 3 %) was used to manufacture the locket (H52-2), which was fire-gilded. A pair of lockets of a similar size but of different material and construction was found in grave 33 from Klecany II (*Profantová et al. 2010*, p. 194). They were made of silver and held a cabochon of lead inside (*Profantová, 2013*, p.29). It is possible that the lockets from the Lumbe Garden necropolis held an identical material or a gem like the medallion from Želénky.

The jingle bells from the "Lumbe Garden" necropolis were made of either cast bronze (H78-1, H78-2, H43-1) or were multi-component copper alloy jewels made by cold working and soldering. Three jingle bells (H78-3, H78-2, H78-1) were fire-gilded.

A total of 53 S-shaped temple rings out of the 62 specimens recovered in the assemblage from the "Lumbe Garden" necropolis were analysed. The results showed that the majority of the S-shaped temple rings were made from solid silver alloys containing 1.6 - 6.3 % copper, with an average of 3.7 %. The obtained results showed, with a few exceptions, that the same material was used to manufacture the S-shaped temple rings enclosed in the same grave. Two S-shaped temple rings from grave H5 (H5-1 and H5-2) were made of a solid binary Ag-Cu alloy with 3.4 % copper and were fire-gilded. Three S-shaped temple rings (H30-1, H30-4, H120-12) were made of brass and one in a copper alloy (99-3). Unlike S-shaped temple rings from Žalov-cihelna, Levý Hradec (*Tomková et al. 2012*, p. 326-332), Loretánské náměstí (*Tomková 2005b*, p. 276-288), Vrbno (*Ottewelter - Hošek - Děd - Štefan 2012*), which were manufactured mainly in copper alloys and, in a more limited number in plated copper alloys or debased silver, the S-shaped temples rings from the "Lumbe Garden" necropolis are exceptional for the recurrence of the use of high quality silver. The heaviest S-shaped temple rings from grave H100 have direct parallels in S-shaped temple rings found in grave 111 in Nitra (*Čaplovič, 1954*, p. 19).

Of the 67 specimens recovered in the necropolis, a total of 38 temple rings with an eyelet were analysed. The majority of the temple rings with an eyelet recovered in the "Lumbe Garden" necropolis are made of solid silver with an average content of 3.8 % copper. A higher copper content (up to 9.3 %) was detected in two specimens from grave H85 (H85-1, H85-6). All the temple rings discovered in grave H104 as well as one specimen from grave H85 (H85-1) were made of ternary alloy containing silver, gold and copper. Temple rings from grave H104 have a gold content of

approximately 4.6 %, while the temple rings from grave H85 have a gold content of only 2.8 %. A total of 11 temple rings with an eyelet were manufactured in a ternary Au-Ag-Cu alloy containing about 60 % gold, 30 % silver, and 8 % copper (grave H67), and 3 specimens were manufactured with copper alloys and were fire-gilded (H52-5, H112-1, H112-2). Finally, 2 specimens were manufactured in copper alloy (H46-1, H46-2) and 1 in brass (H80-1).

For now, it is difficult to compare the results obtained in this study with jewels from other major sites from the same period, since limited studies have been published so far on the nature of the material and construction of early medieval Bohemian and Moravian jewels. Furthermore, most of the analyses performed were analyses obtained by X-ray fluorescence spectrometry (XRF) on surfaces which were probably tarnished and corroded. The obtained results are possibly distorted. Moreover, this method cannot detect coatings properly and the solder area is usually analysed together with the bulk metal, increasing the copper content. In order to compare the raw material, alloys and technology used in Bohemia and Great Moravia, it is necessary to proceed to further technical systematic studies on similar jewels from centres of the Great Moravian Empire (Mikulčice, Staré Město u Uherského Hradiště, Rajhrad-Rebešovice, Pohansko, Nitra) as well as other important contemporaneous centres, especially from significant Bohemian sites such as Buděc and Stará Kouřim. Ideally, analyses should be performed by scanning electron microscopy with energy-dispersive X analysis (SEM/EDS), which allows precise analyses of the component and solder areas in order to establish a database of comparable data. A very detailed examination of the jewels under a microscope prior to analyses and the identification of components, metallic coating, X-radiography are necessary in order to understand the construction and decoration techniques used. The use of available fragments is also very helpful in performing metallographic examinations to gain more precise results than surface analyses. Furthermore, the nature of past treatments performed on the artefacts also has an important impact on the results and must be evaluated. It is important to analyse freshly cleaned and uncorroded surfaces to obtain accurate results. Once these data are available, additional features will complete the typology of the different types of early medieval jewels and it will be possible to identify the potential origin and deduce influences of the Great Moravian Empire and possible changes taking place while being acquired in Bohemia. Local workshops and possibly local goldsmiths and trade routes will be identified more accurately.

ACKNOWLEDGMENTS

The authors wish to express their gratitude to J. Frolík for having given us the chance to work on this extraordinary set of objects as well as G. Plíková and D. Janová for their great involvement in this project and all the hours they spent on performing the analyses and preparing the exploded drawings of the artefacts. Our thanks are also extended to Š. Msallamová who participated in the analyses of the temple rings and to K. Kolářová who prepared most of the available silver fragments for metallography.

